

DIN RAIL SMART UNIVERSAL TEMPERATURE TRANSMITTER

SEM215

- UNIVERSAL INPUT
- QUICK SELECTOR / PC CONFIGURABLE
- GALVANICALLY ISOLATED
- LOOP POWERED
- COMPACT DIN RAIL MOUNTED
- 10 YEAR WARRANTY



INTRODUCTION

The SEM215 is a universal DIN rail mounted temperature transmitter that accepts most commonly used temperature sensors, slide wire transducers or millivolt signals, isolates and transmits them as a (4 to 20) mA signal to a host system. It can be configured by either of the following methods:

Configuration using "Quick Selector"

One of 59 pre-set ranges can be selected by using switches. The switch, located close to the rail clip, is inaccessible in normal use. This "Quick Selector" method does not require any additional calibration, and the transmitter can be put into service immediately after selection is made.

Configuration via PC

The sensor type and range are easily programmed using a PC and a simple Windows based software programme. This allows for re-programming or interrogation of the SEM215 while it is installed in the loop. Sensors can be changed without the need for re-calibration. Special sensors can be accommodated by using the type "X" option, the characterisation for these sensors are factory entered for later retrieval from the menus.

The transmitter is very compact enabling a high packing density to be achieved and by using the latest tension clamp technology for the two part terminals, connections are made in half the time taken to wire conventional screw terminals. These terminations are maintenance free and the tension clamp ensures that the contact is permanently under tension eliminating any potential problem of loosening due to temperature fluctuations or vibration.

INTRODUCTION

INPUTS

Pt100 Platinum resistance sensors, Thermocouples, millivolts or Slidewire sensors may be connected to the unit, plus a 'type X' linearisation option which may be pre-configured at the factory to satisfy any custom characterisation requirements.

The Process Variable may be filtered to remove incoming signal noise using one of four settings. If the 'Adaptive' function is selected the filter continuously adjusts to the incoming signal to noise ratio in order to choose an appropriate level of filtering. In this way a slowly changing input can be heavily filtered but if the signal goes through a sudden change the filter quickly reduces allowing a rapid response, other settings are; off, 2 seconds, 10 seconds.

A user programmable offset is available to remove any system errors that may be present and sensor referencing enables the transmitter to be accurately matched to a particular sensor.

CURRENT OUTPUTS

In normal operation the current output varies between 4 and 20 mA. If the input sensor develops a fault, or the software in either of the two microprocessors detects an error, then the current output is driven either upscale (greater than 20 mA) or downscale (less than 4 mA) depending upon the sense of the burnout parameter selected.

BLOCK DIAGRAM SEM215 schematic

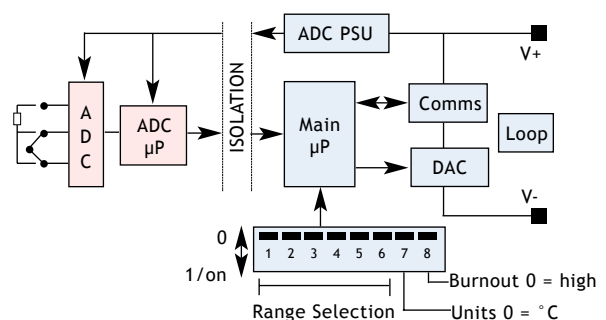

DIN RAIL SMART UNIVERSAL TEMPERATURE TRANSMITTER

SPECIFICATION @ 20 °C @ 24 VDC

INPUT SENSORS AND RANGES

RTD (Pt100)	2 or 3 wire
Sensor Range	(-200 to 850) °C [18 to 390 Ω]
Minimum Span*1	25 °C
Linearisation	Standard BS EN60751/DIN 43760/ JISC 1604/ Custom [X]*3
Basic Measurement Accuracy	± 0.01 % FRI*3 ± 0.05 % rdg
Thermal Drift	Zero 0.008 °C/°C
	Span 0.01 %/°C
Excitation Current	(300 to 550) µA
Maximum Lead Resistance	50 Ω/leg
Lead Resistance Effect	0.002 °C/Ω

THERMOCOUPLE

TYPE	MEASURING RANGE*4	MINIMUM SPAN* C*1
TC Type K	-200 to 1370	50
TC Type J	-200 to 1200	50
TC Type T	-210 to 400	25
TC Type R	-10 to 1760	100
TC Type S	-10 to 1760	100
TC Type E	-200 to 1000	50
TC Type F (L)	-100 to 600	25
TC Type N	-180 to 1300	50
TC Type	±9999	Custom[X]*3

Basic Measurement Accuracy*2	± 0.04 % FRI*5 ± 0.04 % rdg or 0.5 °C (whichever is greater)
Linearisation	IEC 584-1/BS 4937
Cold Junction Error	± 0.5 °C
Cold Junction Tracking	0.05 °C/°C
Cold Junction Range	(-40 to 70) °C
Thermal Drift	Zero 0.1 µV/°C
	Span 0.01 %/°C millivolts
Input	Voltage source
Range	(-10 to 75) mV
Characterisation	Linear Custom [X]*3 (4th Order Polynomial)
Minimum Span*1	5 mV
Basic Measurement Accuracy*2	± 10 µV ± 0.07 % rdg
Input Impedance	10 MΩ
Thermal Drift	Zero 0.1 µV/°C
	Span 0.01 %/°C

SLIDEWIRE

Input	3 wire potentiometer
Resistance Range	(10 to 390) Ω [End to End] (Larger values can be accommodated by fitting a link between terminals 9 & 10)
Characterisation	Linear Custom [X]*3 (4th Order Polynomial)
Minimum Span*1	5 %
Basic Measurement Accuracy*2	0.1 %
Temperature Drift	0.01 %/°C

OUTPUT

Output Range	(4 to 20) mA (min 3.8 to max 20.2 mA)
Max Output	23 mA
Protection	Reverse connection, over voltage 35 V
Accuracy	± 5 µA
Voltage Effect	0.2 µA/V
Thermal Drift	1 µA/°C
Max. Output Load*6	[(V supply -10)/20] KΩ (700 Ω @ 24 V)

GENERAL SPECIFICATION

Input/Output Breakdown Isolation	500 VAC rms
Update Time	250 ms maximum
Response Time (Filter OFF)	< 1 s (to reach 63 % of final value)
Filter Factor	Programmable: Off, 2 s, 10 s or Adaptive (10 to 35) VDC
Supply Voltage	120 s to full accuracy
Warm Up	0.1 % FRI*5 or 0.1 °C/year
Stability	Upscale or downscale
Burn Out	

APPROVALS

EMC	BS EN61326
-----	------------

ENVIRONMENTAL

Ambient Operating Range	(-10 to 70) °C*7
Ambient Storage Temperature	(-40 to 70) °C
Ambient Humidity Range	(10 to 90) % RH non-condensing

ENCLOSURE

Material	ABS
Flammability	SEI UL94-V0

COMMUNICATIONS

PC Interface	RS 232 via interface adapter
Comms Protocol	ANSI X3.28 1976
Data Rate	1200 baud
Minimum Output Load	(100 to 300) Ω for 'In loop' programming
Maximum Cable Length	1000 m
Configurable Parameters	Sensor type: Burnout: °C / °F: Output, available as "Quick Selector" or via PC, Hi/Lo: filter: Tag: User offset, available via PC programming only.

CONNECTOR APPROVALS

IEC 947-7-1/EN

ENVIRONMENTAL TESTS

Low Temperature	IEC 68-2-1
Dry Heat	IEC 512-6-9
Damp Heat	IEC 512-6-3
Damp Heat Cyclical	IEC 68-2-30
Salt Spray	IEC 512-6-6
Sulphur Dioxide	IEC 68-2-46
Hydrogen Sulphide	IEC 68-2-16
Gas Tightness	IEC 512

Pr.11 Wire Size (0.5 to 1.5) mm²

*Alternative connectors with screw terminals are available at extra cost

*NOTES:

- Any span may be selected but full accuracy is only guaranteed for spans greater than the minimum recommended.
- Basic Measurement Accuracy includes the effects of calibration, linearisation and repeatability.
- Customer linearisation is available pre-programmed at the factory, contact sales office for details.
- Consult Thermocouple reference standards for practical temperature ranges.
- FRI = Full Range Input
- Restricted to 300 ohms for in loop programming.
- (-40 to 70) °C operation with Tropicalised Option.

DIN RAIL SMART UNIVERSAL TEMPERATURE TRANSMITTER

MECHANICAL DETAIL

(All dimensions in mm)

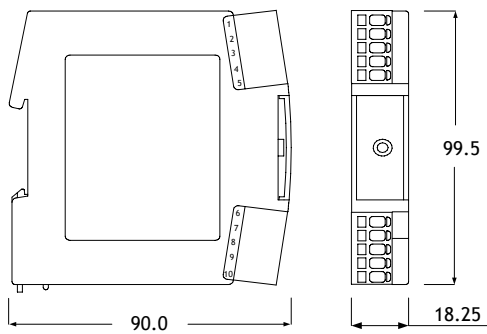

CONNECTIONS

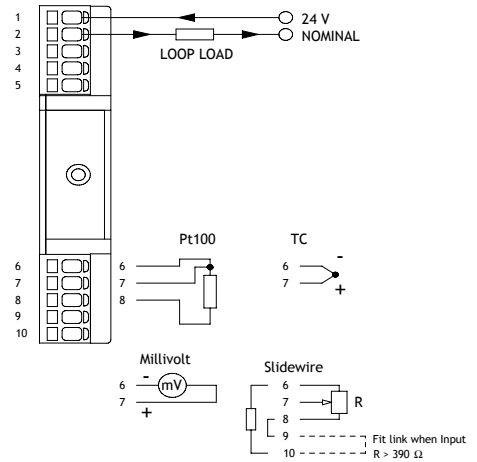

CONFIGURATION DIAGRAM

USING THE CONFIGURATOR MODULE WITH POWER SUPPLY

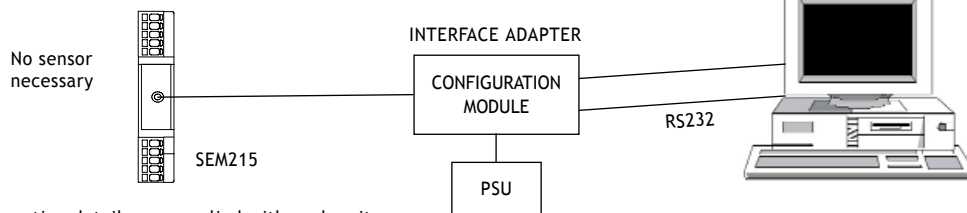

Full configuration details are supplied with each unit.

USING EXISTING LOOP POWER

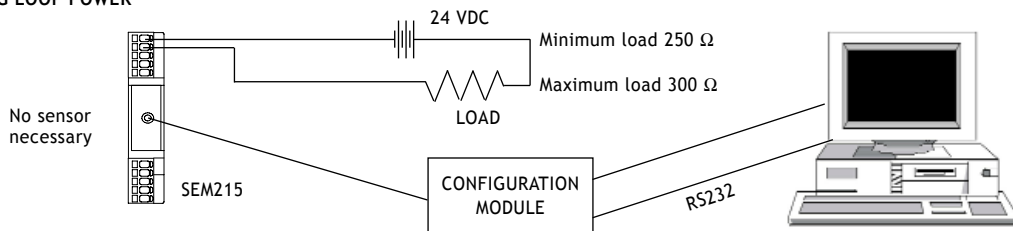

CONFIGURATION



WARNING!

DO NOT CONNECT A POWERED CONFIG MODULE TO A UNIT ON A POWERED LOOP

DIN RAIL SMART UNIVERSAL TEMPERATURE TRANSMITTER

Quick Selector - A small switch, located between the rail clips and inaccessible in normal use, enables sensors and ranges to be selected without the need to use a computer. This 'Quick Select' method does not require any additional calibration and the unit can be used immediately after selection. Sensor and range settings are shown below.

RANGE CODE*	SENSOR TYPE	TEMPERATURE RANGE °C	RANGE CODE*	SENSOR TYPE	TEMPERATURE RANGE °C
0*	PROG.	PROG.	32	Type K T/C	0 to 800
1	Pt100 EN60751	-100 to 100	33	Type K T/C	0 to 1000
2	Pt100 EN60751	-50 to 50	34	Type K T/C	0 to 1200
3	Pt100 EN60751	-50 to 100	35	Type J T/C	0 to 100
4	Pt100 EN60751	-50 to 150	36	Type J T/C	0 to 150
5	Pt100 EN60751	0 to 50	37	Type J T/C	0 to 200
6	Pt100 EN60751	0 to 100	38	Type J T/C	0 to 400
7	Pt100 EN60751	0 to 150	39	Type J T/C	0 to 600
8	Pt100 EN60751	0 to 200	40	Type T T/C	-50 to 50
9	Pt100 EN60751	0 to 300	41	Type T T/C	-50 to 100
10	Pt100 EN60751	0 to 400	42	Type T T/C	0 to 100
11	Pt100 EN60751	0 to 500	43	Type T T/C	-100 to 100
12	Pt100 EN60751	0 to 600	44	Type T T/C	0 to 200
13	Pt100 EN60751	50 to 150	45	Type T T/C	0 to 400
14	Pt100 BS1904	-25 to 125	46	Type R T/C	0 to 1000
15	Pt100 BS1904	0 to 100	47	Type R T/C	0 to 1600
16	Pt100 BS1904	0 to 250	48	Type S T/C	0 to 1000
17	Pt100 BS1904	250 to 500	49	Type S T/C	0 to 1600
18	Pt100 BS1904	-50 to 150	50	Type N T/C	0 to 100
19	Pt100 BS1904	0 to 200	51	Type N T/C	0 to 200
20	Pt100 BS1904	50 to 150	52	Type N T/C	0 to 400
21	Pt100 JISC 1604	-25 to 125	53	Type N T/C	0 to 600
22	Pt100 JISC 1604	0 to 100	54	Type N T/C	0 to 800
23	Pt100 JISC 1604	0 to 250	55	Type N T/C	0 to 1000
24	Pt100 JISC 1604	250 to 500	56	Type N T/C	0 to 1200
25	Pt100 JISC 1604	-50 to 150	57	Type E T/C	0 to 1000
26	Pt100 JISC 1604	0 to 200	58	Type J T/C	0 to 2000*1
27	Pt100 JISC 1604	50 to 150	59	Type K T/C	0 to 2400*1
28	Type K T/C	0 to 100	60	-	-
29	Type K T/C	0 to 200	61	-	-
30	Type K T/C	0 to 500	62	-	-
31	Type K T/C	0 to 600	63	TEST MODE	TEST MODE

*All switches must be set UP (to 'off') in order to programme parameters via a PC. See instruction guide for switch positions. An additional switch position selects °C or °F and another selects Up-scale or Down-scale burnout.*1 °F Only. Full details of the switch settings are provided with each transmitter.

ORDER CODE

SEM215	Standard Unit
RCPW-KIT-UK	Programming kit comprising I.F adaptor box, RCPW* software, PSU and carry case. UK use.
RCPW-KIT-EUR	For European use
RCPW-KIT-USA	For use in USA/Canada
RCPW-KIT-AUS	For use in Australia

*Free updates and demo software available from our website.