

The dry products level control catalogue



mobrey

EMERSON™
Process Management

Mobrey dry products level measurement and control

The measurement and control of dry products is important in all industries, from mining through to fine chemicals. Such is the diversity of product to be measured that no single instrument is capable of reliable operation in all materials.

Mobrey products offer a range of technologies to ensure that users are able to select the most appropriate instrument for the application.

Point level switches for alarm or control duty

- Series PLS Paddle level switch
- Series CLS RF Capacitive level switch
- Series VLS Vibrating Rod level switch



Product selection guide

	Point level switches				
	Paddle PLSK	Paddle PLSH	Capacitance CLSK	Vibrating rod VSLK	Vibrating rod VLSH
Duty					
High level alarm	■	■	■	■	■
Low level alarm	■	■	■	□	□
Level measurement					
Material					
Powder	■	■	■	■	■
Granular	■	■	■	■	■
Pellets	■	■	■	■	■
Aggregate	■	■			
Material density					
Very low	■	■	■	□	□
Low	■	■	■	■	■
Medium	■	■	■	■	■
High	■	■	■	■	■
Very high	■	■			
Material moisture					
Low	■	■	■	■	■
High			■		
Material coating					
Minimal	■	■	■		
Heavy build-up			■		
Corrosive					
Low	■	■	■	■	■
High				■	■
Installation					
Vertical (top)	■	■	■	■	■
Horizontal (side)	■	■	■	■	■
Non-contact (top)					
Temperature					
Ambient	■		■	■	■
Low (to -20°C)	■		■	■	■
High (to +110°C)		■	■	■	
Pressure					
Atmospheric	■	■	■	■	■
Low 2 bar	■	■	■	■	■
Medium 10 bar				■	■
Atmosphere					
Dusty	■	■	■	■	■
Steamy				□	□
Vibration					
Low	■	■	■	■	■
High	■	■	■		

Recommended Possible Not recommended

Some typical dry products bulk densities (Kg/m³)

Very low	
Up to 100kg/m ³	
Powdered carbon	80
Bread crumbs	96
Polyethylene flakes	95
Low	
100 - 250kg/m ³	
Soap flakes	160
Ground cork	160
Charcoal	208
Sawdust	210
Medium	
250 - 1000kg/m ³	
Bran	256
Rolled oats	304
Powdered milk	450
Flour	596
Grain	6-800
Granulated sugar	849
High	
1000 - 2000kg/m ³	
Soot	1024
Coal	1100
Fine salt	1201
Cement	1506
Dry sand	1602
Very high	
Over 2000kg/m ³	
Gravels	2000-2500
Aggregates	2000-2500
Earth	2000
Slag	2100

Series PLS Paddle switches

Traditional switch used to detect high or low levels of most free flowing bulk solids and powders. The paddle rotates freely in the absence of material but is impeded when material is present, operating a microswitch output

Features	Applications
Time proven	Aggregates, granular, pelletised or powdered dry products
Simple and reliable	High, intermediate or low level alarm
Top or side mounting	
Safepoint failsafe model with fault relay	



cost effective

Applications	Free flowing dry products, very low - very high density
Power supply	98V ac to 270V ac 24V dc +/- 15%
Output	Standard model: 2 x SPDT control relays, 15A at 250V ac
Conduit connection	2 x 3/4" NPT (NPT models) or 2 x M20 (BSPT models)
Operating temp.	-40°C to +149°C All high temperature models: -40°C to +399°C
Operating pressure	2 bar maximum
Productside material	Type 304 stainless steel
Housing material	Aluminium alloy, powder paint coated
Housing rating	IP66
Approvals	ATEX II 1/2 D

Series CLS RF Capacitance probes

This self calibrating RF capacitance level switch includes a microprocessor controlled Powershield probe which overcomes the effects of product build up on the probe, allowing reliable use in a wide range of free flowing and sticky dry products

Features	Applications
No moving parts	Granular, pelletised or powdered dry products
Material build up compensator	Sticky or clinging products
Self calibrating	Sludges and slurries
Adjustable time delay	High, intermediate or low level alarm
Top or side mounting	
Rigid or flexible probe	



build up compensator

Application	Powders and granules $\varnothing < 20\text{mm}$, very low - high density Minimum DK: 2
Power supply	104V ac to 245V ac 50/60Hz 21.6 to 25.2V dc
Output	1 x SPDT control relay, 2.5A at 250V ac
Conduit connection	2 x 3/4" NPT (NPT models) or 2 x M20 (BSPP models)
Response time	Adjustable 1 to 128 seconds
Operating temp.	-20°C to +100°C
Operating pressure	7 bar maximum
Productside material	Type 304 stainless steel probe Polypropylene powershield
Housing material	Glass filled nylon, paint coated
Housing rating	IP65
Approvals	ATEX II 1 D

Series VLS Vibrating Rod switches

Single probe design of vibrating level switch for free flowing materials which eliminates the problems of clogging and bridging of fork designs

Features	Applications
No moving parts	Granular, pelletised or powdered dry products
High & low level failsafe	High, intermediate or low level alarm
Adjustable time delay	
Sensitivity adjustment	
Extended probe option	
Top or side mounting	



no clogging

Application	Free flowing powders & granules $\varnothing < 10\text{mm}$, low - high density
Power supply	85V ac to 265V ac 50/60Hz 19 - 55V dc
Output	1 x SPDT control relay, 8A at 250V ac
Conduit connection	2 x 1/2" NPT (NPT models) or 2 x Pg16 (BSPT models)
Response time	Selectable 2 or 5 seconds
Operating temp.	-20°C to +160°C
Operating pressure	10 bar maximum
Productside material	Type 316 stainless steel
Housing material	Al. alloy, powder paint coated
Housing rating	IP67
Approvals	ATEX II 1/2 D

Series PLS Paddle level switch

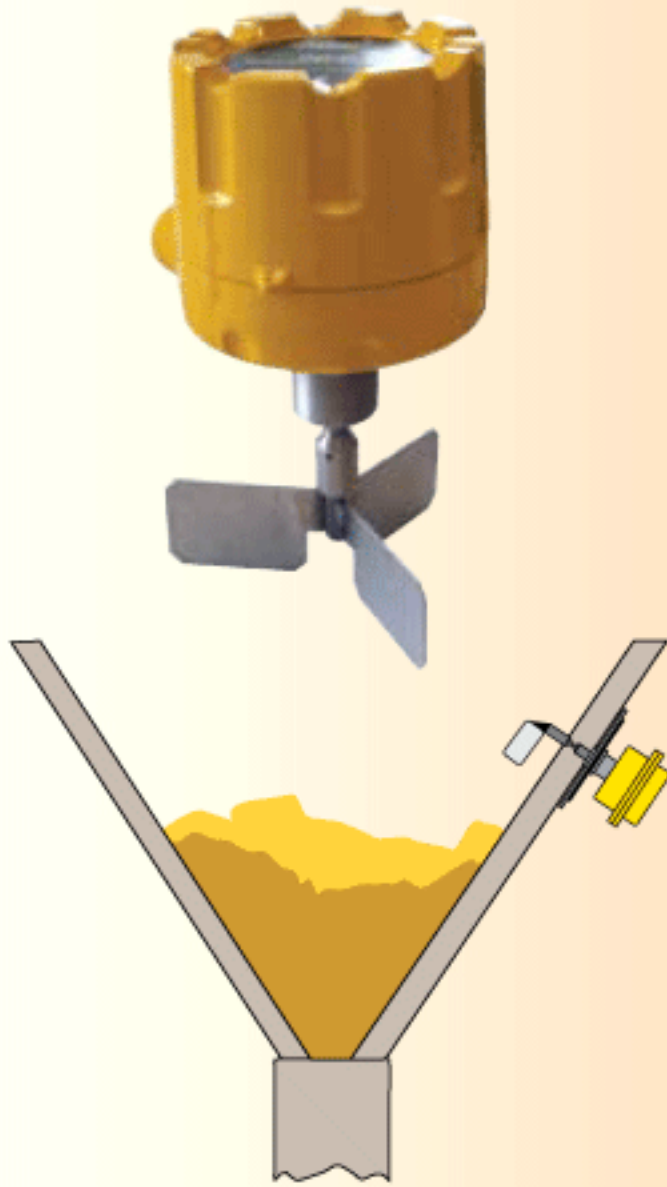

The paddle switch may be used as either a high or low level limit switch for dry products and is easily mounted through the wall of the vessel such that the paddle protrudes inside the vessel. A small electric motor drives a paddle which rotates freely in the absence of material.

When the paddle is impeded by the presence of material, the motor rotates within the housing to actuate a microswitch and signal an alarm. As soon as the paddle is stopped from rotating, power to the motor is cut, thus extending motor life. Once the material level falls the motor is returned to its normal position and the paddle begins to rotate again.

The failsafe Safepoint model incorporates magnetically operated detection circuits which can differentiate between paddle rotation being stopped by material presence

or by any electrical or mechanical failure of the product, then operate an independent fault relay.

Application

Series PLS switches can be used with granular, pelletised and powdered dry products and may be used in high level applications with materials over 160kg/m³ and low or intermediate applications with materials over 80kg/m³.

Selection

Using the ordering code below as a selection guide, specify the particular PLS model required for your application.

Refer then to the paddle and accessories selection guide on the adjoining page to select and specify the appropriate paddle and any mounting accessories.

Paddle switch ordering information: Order paddle and accessories using part numbers on adjoining page

PLS		Paddle Level Switch series			
Code	Model	Code	Mounting		
K	Standard model, 2 x SPDT alarm relays	B1	R 1 1/2" BSPT mounting (except high temp.)		
H	High temperature standard model, 2 x SPDT alarm relays	N1	1 1/4" NPT mounting (all models)		
P	Failsafe Safepoint model with fault relay and 1 x SPDT alarm relay	Code	Housing		
T	High temperature failsafe Safepoint model with fault relay and 1 x SPDT alarm relay	3	Aluminium alloy housing		
		Code	Voltage		
		0	115V ac motor voltage		
		1	240V ac motor voltage		
		2	24V dc motor voltage		
		Code	Approvals		
		A	ATEX Dust approval		
		Z	No hazardous area approvals		
PLSK	B1	3	1	Z	Order paddles and accessories separately

Technical specification

Power supply	115V ac +/- 15%, 50/60Hz 230V ac +/-15%, 50/60Hz 24V dc +/- 15%	Operating temp.	Standard: -40°C to +149°C Safepoint: -40°C to +121°C All high temperature models: -40° C to +399°C
Power consumption	4W max	Ambient temp.	Standard: -40°C to +93°C Safepoint: -40°C to +65°C
Output	Standard model: 2 x SPDT control relays, 15A at 250V ac	Housing material	Aluminium alloy, powder paint coated
	Safepoint model: 1 x SPDT control relay, 5A at 250V ac 1 x SPDT fault relay, 5A at 250V ac	Housing rating	IP66
Conduit connection	2 x 3/4" NPT (NPT models) or 2 x M20 (BSPT models)	Weight	Typical standard model: approx. 4kg
Operating pressure	2 bar maximum	Approvals	ATEX II 1/2 D UL and CSA CLI Div 1 & 2, Gr. C,D, CLII Div 1 & 2, Gr. E,F,G (Pending)
Wetside material	Type 304 stainless steel		

Paddle selection

	Scimitar	Single vane	3 Vane std	3 Vane large	2 Vane	4 Vane	Triangular	Belt vane
Order part no.	P4193	P4145	P4146	P4141	P4135	P4156	P4144	P4137
Application								
Heavy material >2000 kg/m ³ >40mm Ø	high							■ *1
	low							■ *1
Heavy material >2000 kg/m ³ <40mm Ø	high	■ *1			■ *1	■ *1		
	low	■ *1			■ *1	■ *1		
Medium material 250 kg/m ³ to 1000 kg/m ³	high	■		■		■	■	
	low	■	■	■		■	■	
Light material up to 250 kg/m ³	high	■			■		■	
	low	■			■		■	
Mounting	Insertable	Insertable	Plate or flange	Plate or flange	Plate or flange	Plate or flange	Plate or flange	Plate or flange
Notes	*1 Flexible coupling required						■ = Recommended	

Flexible coupling

The flexible coupling works to absorb heavy loads, side loads and loads caused by product surges. A flexible coupling should always be used in top mount installations where a solid shaft extension is used.

Shaft extensions

Many top mount installations require that the paddle extends into the vessel to a pre-determined level. Solid shaft extensions in stainless steel are available to customer order up to 1800mm in length. Multiple sections can be supplied to achieve lengths of up to 3600mm. Always specify a flexible coupling and a shaft guard with a solid shaft extension.

Order part no. P-1175-2/****mm

Alternatively a 2000mm stainless steel flexible cable extension is available which may be cut to length on site and eliminates the need for the flexible coupling and shaft guard.

Order part no. P-1176-2

Shaft guard

A stainless steel shaft guard should be specified when a solid shaft extension is required. The shaft guard should be

ordered as the same length as the shaft extension. Maximum length is 1800mm for lengths of up to 3600mm, multiple sections can be supplied complete with assembly coupling. Contact Mobrey sales office for details.

Order part no. P-1174-2/****mm

Flexible coupling

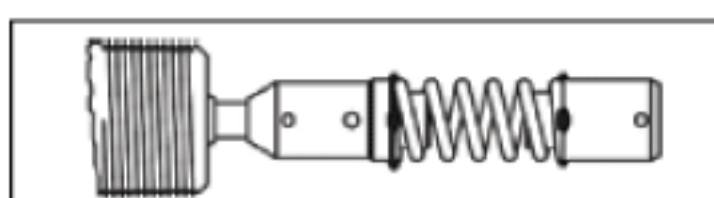

Order part no. P3335

Dimensions: standard model

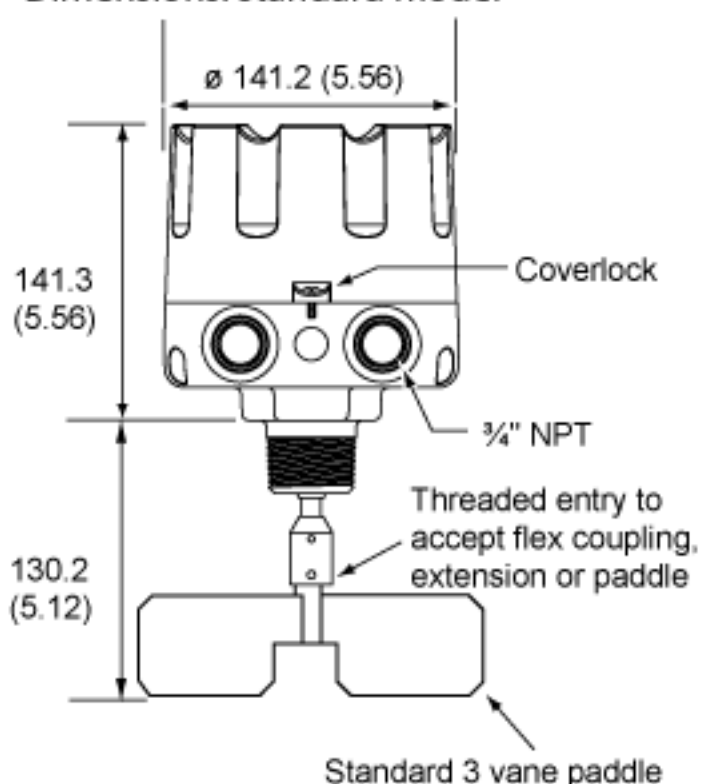

Mounting plate

A mounting plate allows mounting to a curved or flat surface and is particularly advantageous if the paddle to be used is not an insertion type. Two types are available: (Note: use only with NPT thread mounting paddle switches) Half coupling style in stainless steel for use in side mount applications. Full coupling style in stainless steel for use in top mount applications where a shaft extension and shaft guard is required. (Note: included as standard on high temperature option.)

Mounting plate

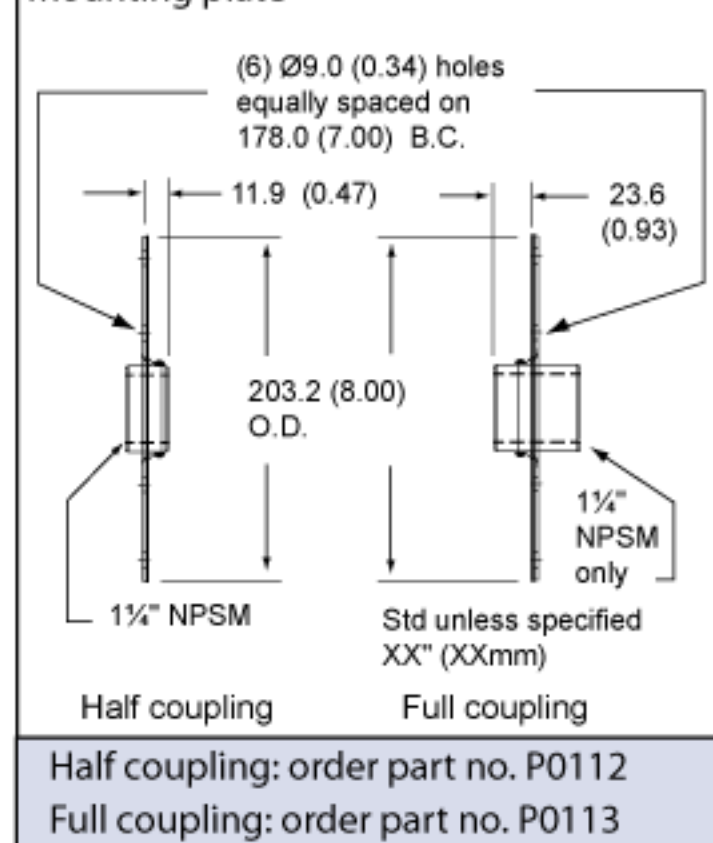

Series VLS Vibrating rod level switch

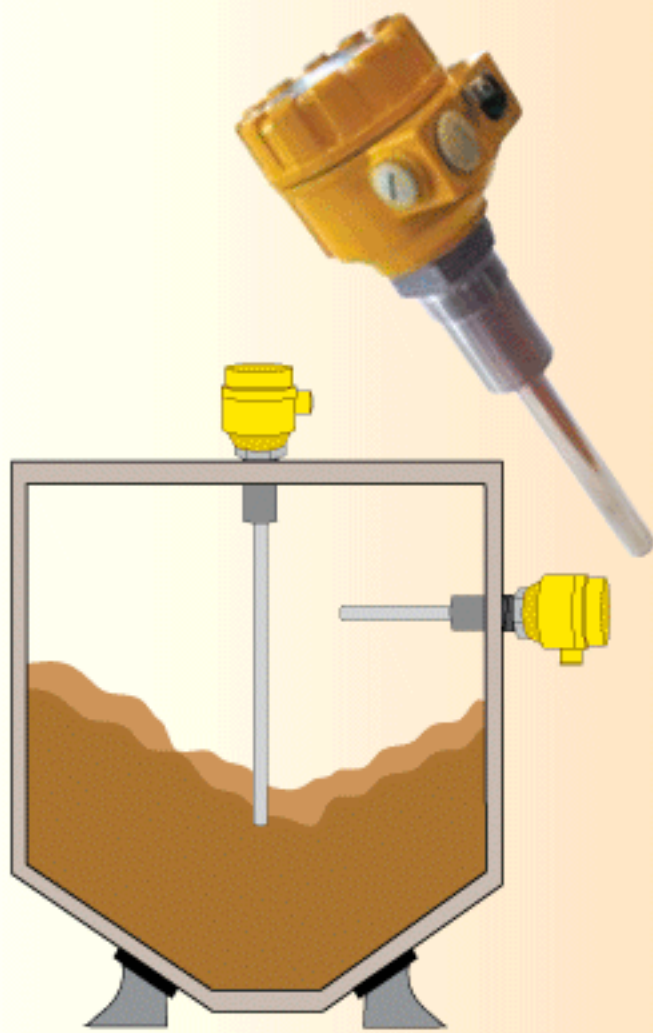

The vibrating rod level switch is the perfect solution for single point level switching in free flowing solids across a wide density range, from fine powders to grains.

The single rod design provides the solution to tuning forks which may become blocked or bridged.

The vibration rod is energised and kept in resonance by an electronic circuit. When covered by material the damping of the vibration will be detected by the electronics which initiate the switching of the output relay after a built-in programmable time delay.

Application

The VLS is designed to provide high or low level switching in silos or bins containing free-flowing powders and granular materials such as carbon black, sugar, grain, cement, lime and sand with a material bulk density of 50 kg/m³ or more.

Requiring only a 1½" BSP/NPT socket, either on the top or in the sidewall of the silo, the unit is easy to install and simple to commission.

Selection

Using the ordering code below as a guide, specify the particular switch and probe style for your application.

Ordering information

VLS Vibrating Rod Level Switch series	
Code	Model
K	Standard model, 1 x SPDT alarm relay
H	High temperature standard model
Code	Mounting
B	R 1 ½" BSPT mounting
N	1 ½" NPT mounting
Code	Insertion length
1	Standard rod: 235mm insertion length
3	Extended rod: 300 to 3000mm insertion length ^{*see note}
4	Cable extended: 1000 to 20000mm insertion length ^{*see note}
8	Extended rod with adjustable gland: 300 to 3000mm ^{*see note}
Code	Housing
3	Aluminium alloy housing
9	Remote electronics
Code	Voltage
1	85 - 265V ac
2	19 - 55V dc
Code	Approvals
A	ATEX Dust approval
Z	No hazardous area approvals
Code	Special
/****	Extension length (rod, cable) ^{*see note}
VLS	K B 1 3 1 Z
Typical model number	

Note: For extended rods order in 100mm increments.
For cable extended order in 1000mm increments.

Specification

Power supply	85V ac to 265V ac 50/60Hz 19 - 55V dc	Ambient temp.	-20°C to + 60°C
Output	1 x SPDT control relay, 8A at 250V ac	Operating pressure	10 bar maximum
Conduit connection	2 x ½" NPT (NPT models) or 2 x Pg16 (BSPT models)	Wetside material	Type 316 stainless steel
Response time	Selectable 2 or 5 seconds	Housing material	Aluminium alloy, powder paint coated
Operating temp.	Standard model -20°C to +110°C High temp model -20°C to +160°C	Housing rating	IP67
		Weight	Approx. 2kg
		Approvals	ATEX II 1/2 D

Options

Dimensions (mm)

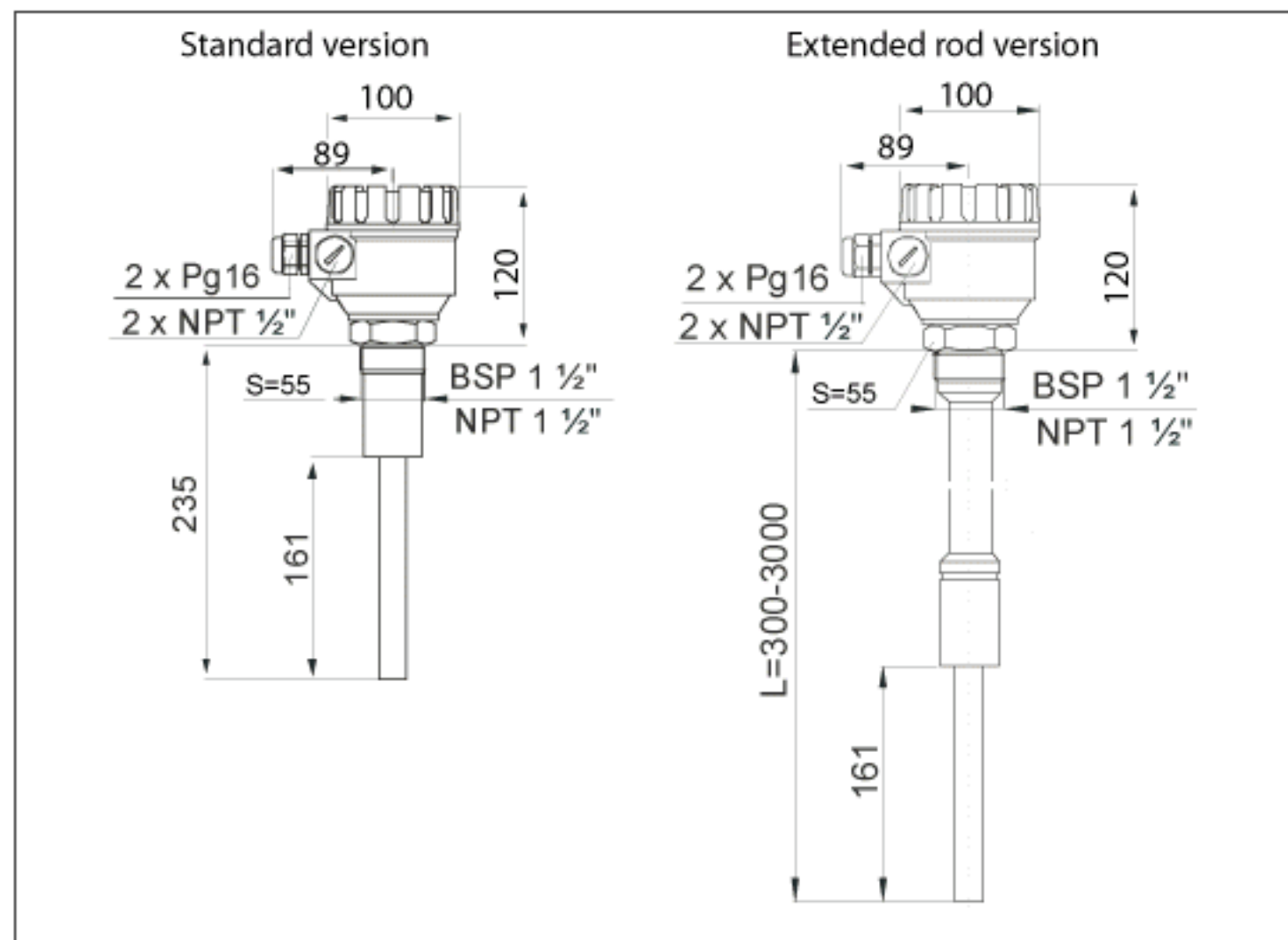

Installation examples

Granular material

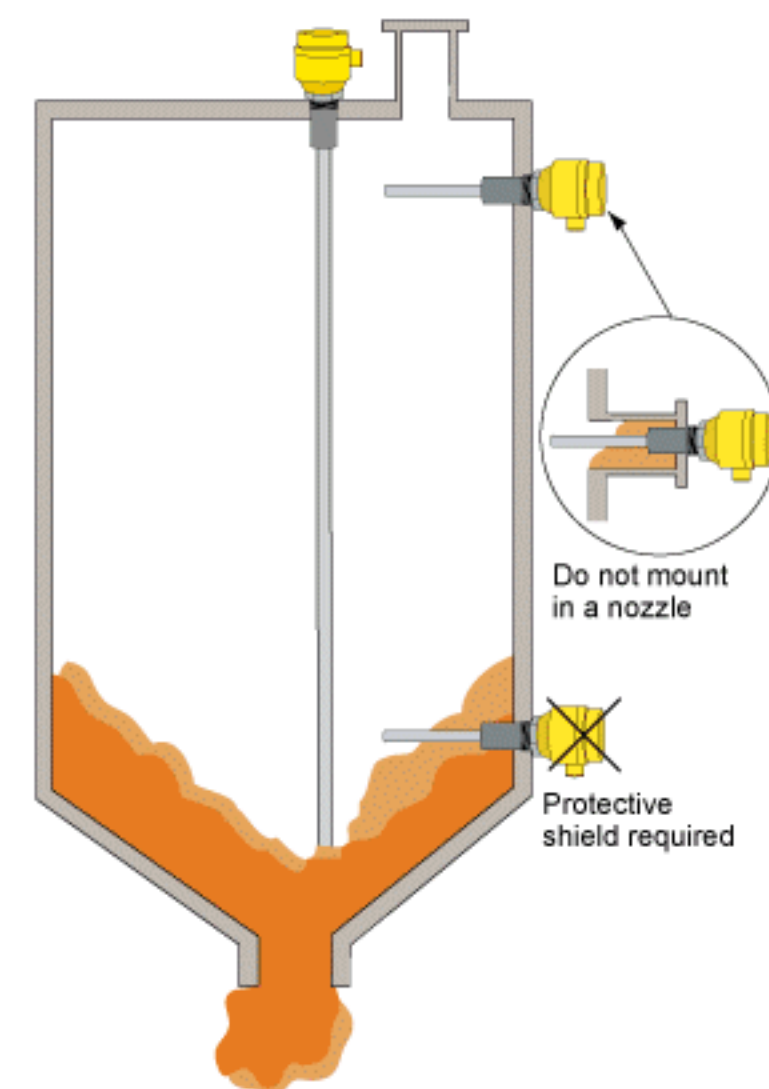

Sensitivity selection

Bulk materials vary greatly in their characteristics.

The VLS will operate in bulk materials with density over 50kg/m^3 - the user must however set the sensitivity selection switch to either LOW for products with density less than 100kg/m^3 or to HIGH for products with density greater than 1000kg/m^3 .

Failsafe operation

Each VLS may be set to either failsafe high or failsafe low using a switch in the electronics housing.

Side mounting

Ideal for use as a failsafe high level switch. When used in a low level application, it is desirable to protect the probe from excessive pressure exerted by the medium and from direct impact when the silo is being filled. A simple shield mounted above the probe is sufficient.

Top mounting

Either in standard length or extended length, mounted vertically in the silo. The cable extended probe which has a length of tough stainless steel cable between probe and mounting point, is ideal for very tall silos.

Adjustable

A top mounting extended probe fitted with an adjustable gland which allows the user to fix the probe at the desired switching level.

	High level	Low level
Standard	Side mount	Side or bottom mount
Pipe extended	Top mount	Side or bottom mount
Cable extended	Top mount	Top mount

Powders

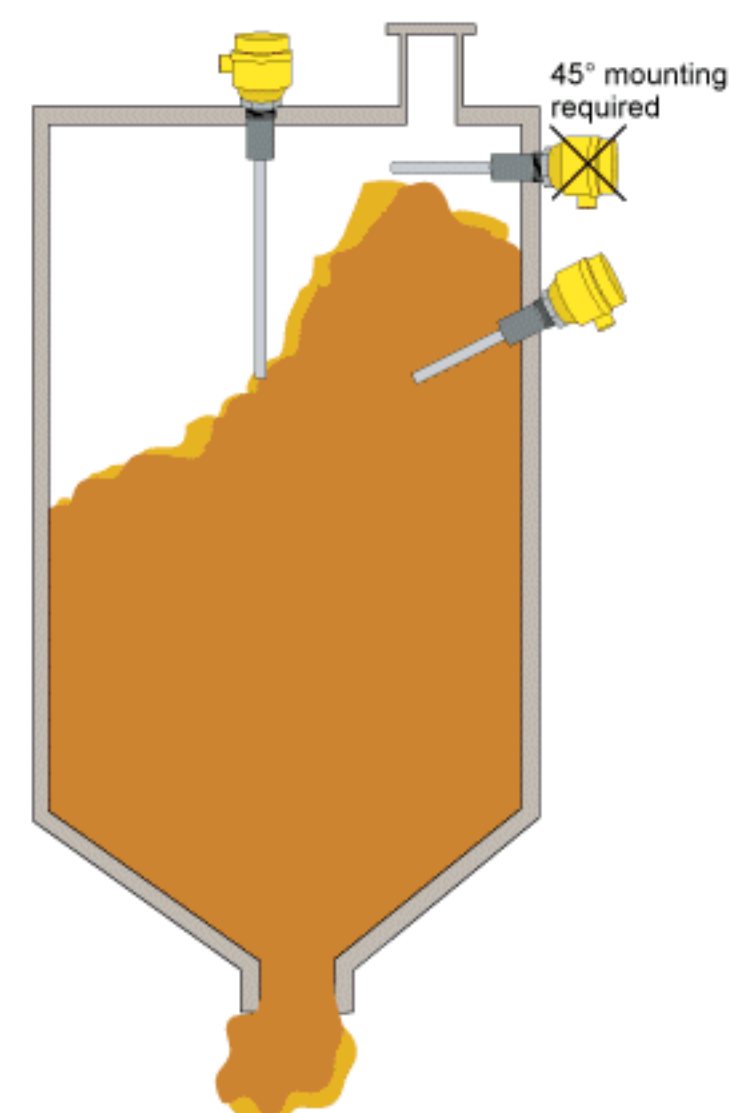

Series CLS RF Capacitance level switch

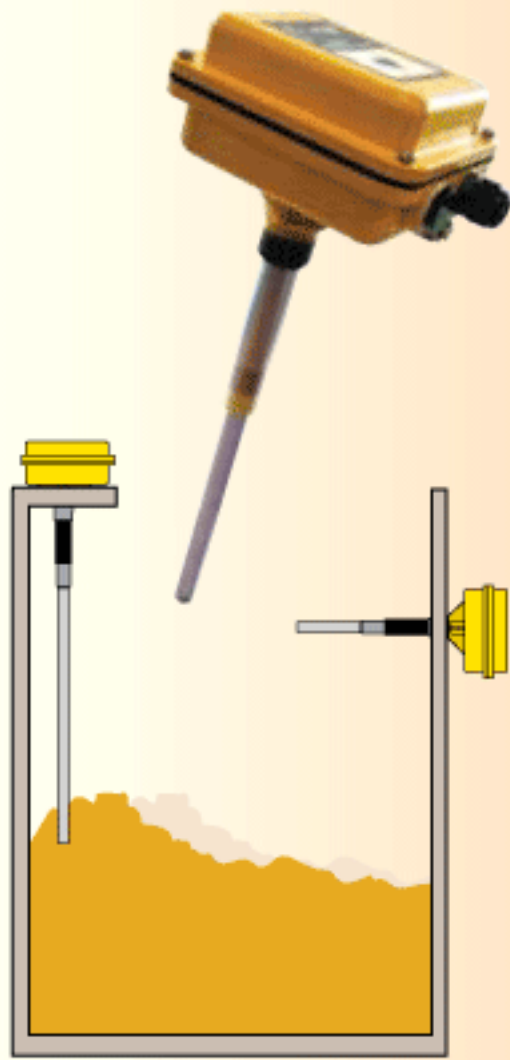

The CLS level switch is a microprocessor based, self calibrating level control with no moving parts, operating using the RF Capacitance principle. Used for either high or low level alarm in silos and hoppers of dry products, the CLS detects the presence or absence of products by monitoring the change in capacitance around the probe as it becomes covered or uncovered. CLS will operate reliably in metal, plastic or wooden silos. A built-in "Power Shield" is used to overcome the effects of product build-up on the probe when used with sticky or viscous products.

A variety of probe styles are available to allow side or top mounting with the facility for users to modify the probe to suit application constraints.

Application
Series CLS switches can be used with any free flowing granular, pelletised or powdered dry product, and also with difficult dry products which have a tendency to coat or build-up, such as animal feed and foundry sand.

Selection
Using the ordering code below as a guide, specify the particular switch and probe style required for your application.

Ordering information

CLS	RF Capacitance Level Switch Series						
	Code	Model					
	K	Standard model, 1 x SPDT alarm relay					
		Code	Mounting				
		B	G 1" BSPP mounting with power shield				
			Code	Insertion length			
			1	200mm Standard rod: 344mm insertion length			
			2	100mm Short rod: 244mm insertion length			
			3	880mm Long rod: 1024mm insertion length			
			4	Wire rope probe: 10000mm insertion length			
			Code	Housing			
			4	Glass filled nylon housing			
			9	Remote electronics in glass filled nylon housing - pending			
			Code	Voltage			
			1	110/230V ac / 24V dc selectable			
				Code	Approvals		
				A	ATEX Dust approval		
CLS	K	B	1	4	1	A	Typical model number

Specification

Power supply	104V ac to 245V ac 50/60Hz 21.6 to 25.2V dc	Ambient temperature	-15°C to + 50°C
Minimum DK	2	Operating pressure	7 bar maximum
Output	1 x SPDT control relay, 2.5A at 250V ac	Wetside material	Probe: 304SS Powershield 316SS partially coated with PTFE. Insulation nylon 66
Conduit connection	2 x 3/4" NPT (NPT models) or 2 x M20 (BSPP models)	Housing material	Glass filled nylon, paint coated
Response time	Adjustable 1 to 128 seconds	Housing rating	IP65
Operating temperature	-20°C to + 70°C (when ATEX certification not required) -20°C to + 50°C (ATEX certification)	Weight	Approx. 2.3kg with standard rod
		Approvals	ATEX II 1 D

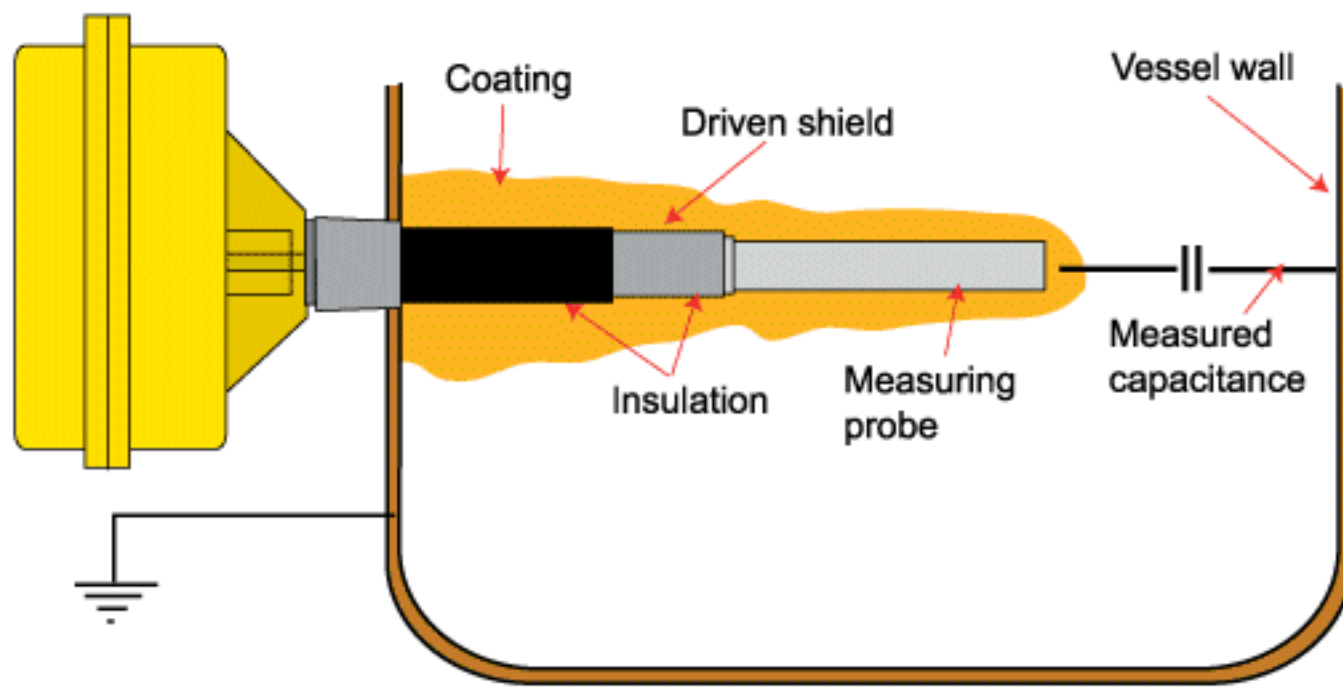

Simple capacitance probes operate by driving the probe to apply an RF signal between the stainless steel probe and the vessel wall. With the probe in free air, which has a dielectric value of 1.0, electronic circuitry measures the standing capacitance around the probe. When the air is displaced by material with a higher dielectric value the capacitance measured increases and an alarm can be triggered.

In free flowing materials of sufficient dielectric value this type of probe is generally acceptable. However, any material build-up on the probe will quickly change the capacitance and be seen as a false level.

The CLS switch solves this problem by the inclusion of a Power Shield. This is a second active section of the probe, termed the driven shield, which is insulated from the measuring probe. See illustration above.

The Power Shield is energised with the same voltage frequency and phase as the measuring probe and therefore no potential can be measured between the power shield and probe. This effectively creates a barrier or shield and prevents the probe from monitoring capacitance to the adjacent sidewall, substantially minimising the effect of build-up in the majority of cases.

Calibration

Having set the site adjustable High \ Low switch to the desired position for failsafe high of low level duty, the CLS must then be calibrated for the product in the silo. Automatic calibration is simply achieved by pressing one button when the probe is uncovered and then a second when the probe is covered by the product.

Sometimes it is not possible to fill the silo so a manual calibration facility is provided where the user manually enters a value of capacitance equivalent to a covered probe. The manual gives full guidance and a table of typical capacitance values.

Time delay

The CLS has a user adjustable time delay facility from instant to 128 seconds, which may be set to delay switching from covered to uncovered or vice versa.

Probe modification on site

It may be that application constraints prevent the use of the standard probe supplied. In such cases, local modification is permissible within limits. As the sensitivity of the CLS is proportional to the surface area of the sensing probe, any modification should maintain the surface area presented to the product in the silo unless the product has high density and dielectric properties.

Dimensions

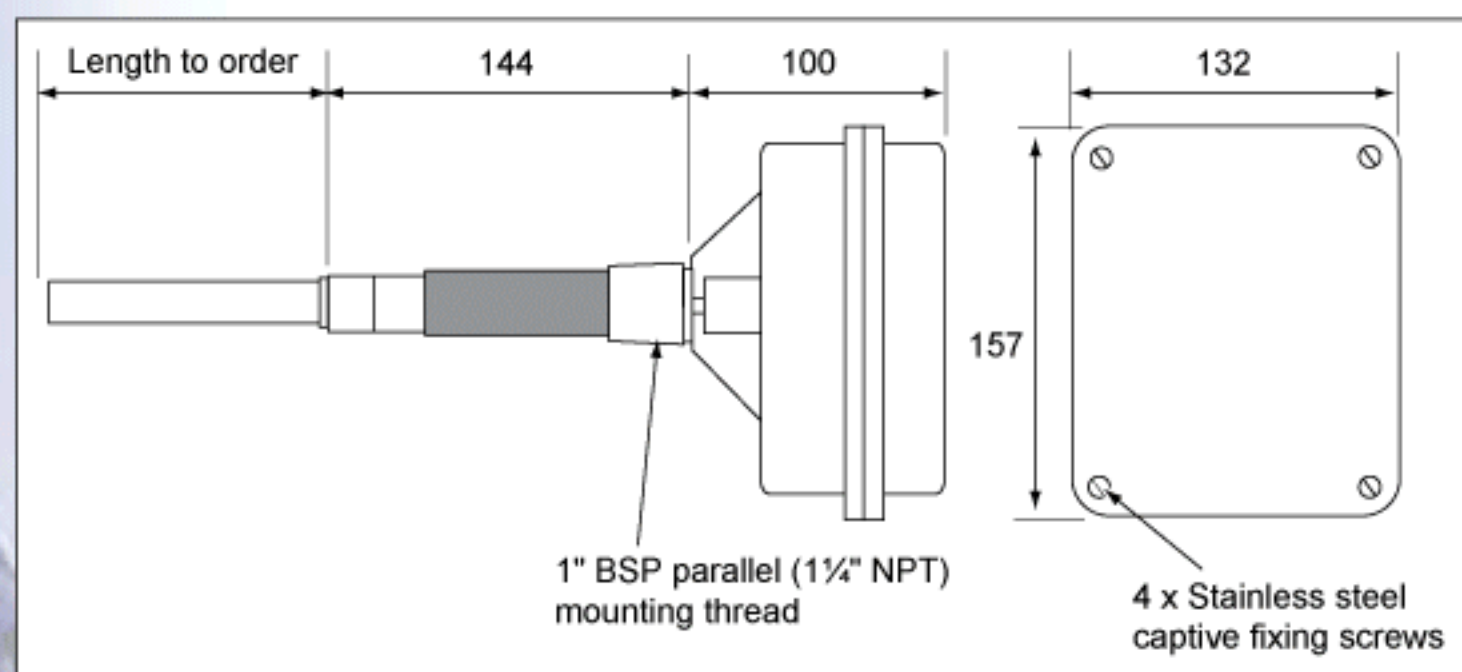

The Emerson logo is a trade mark and service mark of Emerson Electric Co.

Rosemount is a registered trademark of Rosemount Inc.

Mobrey is a registered trademark of Mobrey Ltd.

All other marks are the property of their respective owners

We reserve the right to modify or improve the designs or specifications of product and services at any time without notice.

International:

**Emerson Process Management
Mobrey Measurement**

158 Edinburgh Avenue, Slough,

Berks UK SL1 4UE

T +44 (0)1753 756600

F +44 (0)1753 823589

www.mobrey.com

Ward Industries Limited

Providence House, Brooks Road

Raunds, Northamptonshire

NN9 6NS, England

Tel: +44 (0) 1933 624963

Fax: +44 (0) 1933 625458

Email: sales@wardindustries.co.uk

www.wardindustries.co.uk

Literature reference number IP400 April 2009



EMERSON™
Process Management