

## Pressure Transmitter: **Analogue Series 387**

**387  
ISSUE F.1**

- High Accuracy  $\pm 0.15\%$ .
- Ranges from 1 bar to 1000 bar.
- 4 : 1 turndown.
- 4-20mA analogue with digital communications.
- 316 stainless steel investment Cast Enclosure.
- NEMA 4X, IP66 weatherproof rating.
- Stainless Steel, Monel and Hastelloy “Wetted Parts” options.
- NACE MR-01-75 compatibility.
- All welded construction.

### Performance **characteristics**

#### Enclosure options

- Weatherproof IP66 Protection – NEMA 4X
- Intrinsically safe – EExia ATEX
- Flameproof – EExd ATEX

#### Wetted parts options

- Welded 316 stainless steel sensor and process connection.
- Welded Nickel Alloy (Monel) sensor and process connection.
- Welded Hastelloy sensor and process connection.

#### Signal output

- Refer to table 6.

#### Process connection

- $\frac{1}{2}$ ” NPT External
- G  $\frac{1}{2}$ ” A to ISO 228 (1/2” BSP Parallel Male, spigotted).
- High pressure cone and thread (autoclave) 9/16” UNF.

#### Unit weight

- 900g

#### Accuracy

- For turndowns of 1:1 to 4:1  $\pm 0.15\%$  of span.



### Product **applications**

**The 387 is suitable for a wide range of applications in many Industry sectors:**

- Oil & Gas
- Chemical
- Petrochemical
- Water
- Power

**The choice of models available ensures that the 387 is:**

- Suitable for use in corrosive atmospheres
- Resistant to chemical attack

#### How can we **help you?**

Delta Controls' range of reliable pressure and temperature measurement instruments can be customised to meet individual requirements. For technical advice or to discuss your application, please contact us on +44 (0) 20 8939 3500

## Enclosures

### FINISH

All enclosures are investment cast in 316 Stainless Steel and offer environmental protection to (NEMA TYPE 4X) IP66.

**NOTE:** Instruments subject to National or International approval may be limited in terms of options available. See notes adjacent to relevant tables.

TABLE 1

TABLE 1	Code
Intrinsically Safe to EN50 014 & EN50 020 EEx ia IIC T4 @ 90°C EEx ia IIC T5 @ 40°C	4
Flameproof to EN50 014 & EN50 018 EEx d IIC T6 @ 40°C	R
Weatherproof only IP66/NEMA 4X	A
Factory Mutual Listed Explosionproof Class I, II & III Div 1 Gp BCDEFG Intrinsically Safe Class I, II & III Div 1 Gp ABCDEFG Non Incendive Class I, II & III Div 1 Gp ABCDFG	F

## Models

TABLE 2

	Code
Single Pressure transmitter	387

## Electrical Entry

M20 x 1.5 (ISO) and 1/2" NPT Internal threads available as standard. Other threads e.g. Pg 13.5, can be made available via adaptors.

TABLE 3

	Code
M20 x 1.5 Internal thread (standard)	1
1/2" NPT Internal thread	2

## Material of Wetted Parts

Options T, U and C are all compatible with the requirements of NACE MR 01-75. Other factors in highly aggressive chemical environments may determine the final choice.

For Sour-gas and Crude applications, Code C offers the most cost effective solution.

Monel Code T is preferred for highly oxidising media, such as pure Oxygen and Chlorine.

TABLE 4

TABLE 4	Code
For liquids and gases. Welded 316 stainless steel sensor and process connection. Ranges 0 to 1 bar up to 0 to 6 bar.	R
For liquids and gases. Welded 17-4 PH or 15-5 PH sensor to 316 stainless steel process connection. Ranges 0 to 10 bar up to 0 to 1000 bar.	S
Welded nickel alloy (Monel) sensor and process connection. Ranges 0 to 10 bar up to 0 to 1000 bar (Suitable for NACE MR-01-75).	T
Welded Hastelloy C sensor and process connection. Ranges 0 to 10 bar up to 0 to 1000 bar. (Suitable for NACE MR-01-75).	U
Welded Hastelloy C sensor to annealed stainless steel process connection. Ranges 0 to 10 bar up to 0 to 1000 bar. (Suitable for NACE MR-01-75)	C

## Setting Ranges

The values shown in this table are the UPPER RANGE LIMIT (URL); a 4:1 turndown facility enables full 4 to 20mA output to be obtained for a working span equal to 25% of URL.

Unless specified, the instruments are despatched with LOWER RANGE VALUE (LRV) set to zero and UPPER RANGE VALUE (URV) set to URL.

## Medium Pressure

### Material Code "R" only. (Table 4)

Accuracy  $\pm 0.15\%$   
Maximum working pressure  
 $P_{max} 2 \times URL$ .

Available on models 4387, A387 and F387\*

\*Intrinsically Safe and Non incendive only

## High Pressure

### Material Codes "S, T, U and C". (Table 4)

Code S: Accuracy  $\pm 0.15\%$   
Maximum working pressure ( $P_{max}$ )  
 $2 \times URL$ .

Codes T,U and C: Accuracy  $\pm 0.25\%$ .  
Maximum working pressure ( $P_{max}$ )  
 $1.5 \times URL$ .

\*Subject to 1500 bar (22,500psi) maximum.

Available on models 4387, A387, F387 and R387.

Note: **Range codes GAB and GAP are only available with wetted parts codes 'S', 'U' and 'C' Ref. Table 4.**

TABLE 5

Ranges shown are to gauge (i.e. atmospheric reference; absolute pressure is called up by amending the last character of the three character range code:

Bar/mbar absolute   \*\*A  
Psi absolute       \*\*Q

If range settings are required which cannot be achieved within the adjustment range of zero and span controls, refer to special engineering

Table 5A			
Bar	Code	PSI	Code
0 to 1	DAB	0 to 16	DAP
0 to 1.6	DBB	0 to 25	DBP
0 to 2	D2B	0 to 30	D2P
0 to 2.5	DCB	0 to 40	DCP
0 to 4	DDB	0 to 60	DDP
0 to 6	DEB	0 to 100	DEP

Table 5B			
Bar	Code	PSI	Code
0 to 10	EAB	0 to 160	EAP
0 to 16	EBB	0 to 250	EBP
0 to 25	ECB	0 to 400	ECP
0 to 40	EDB	0 to 600	EDP
0 to 60	EEB	0 to 1000	EEP
0 to 100	FAB	0 to 1600	FAP
0 to 160	FBB	0 to 2500	FBP
0 to 250	FCB	0 to 4000	FCP
0 to 400	FDB	0 to 6000	FDP
0 to 600	FEB	0 to 10,000	FEP
0 to 1000	GAB	0 to 15,000	GAP

## Signal Output

All 4-20mA.

Code M is only available with wetted part material codes C or U. Ref Table 4.

TABLE 6



	Code
4 to 20mA, 2-wire system. 4mA equivalent to nominal zero input pressure. Span of unit adjustable so that 20mA may be equivalent to any pressure between 25% and 100% of Upper Range Limit. Maximum permitted voltage between circuit and case, 50V DC	6
4 to 20mA, 2-wire system. 4mA equivalent to nominal zero input pressure. Span of unit adjustable so that 20mA may be equivalent to any pressure between 25% and 100% of Upper Range Limit. Maximum test voltage between circuit and case, 500V AC.	M

## Process Connection

Other thread specifications and sizes are available without using adaptors.

Adaptors are available for applications where their use is permitted.

**NOTE:** All 1/2" NPT process connections are limited to a maximum over range pressure of 1200 bar / 17,500 psi.

TABLE 7

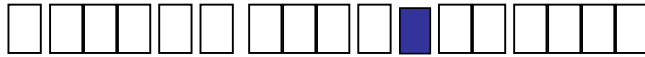

	Code
1/2" NPT Male external (standard)	J
G1/2"A to ISO 228 (1/2" BSP Parallel Male, spigotted)	N
High Pressure Cone and Thread (Autoclave) 9/16" UNF	V

## Options and Treatments

For requirements that fall outside the specifications listed above we will be pleased to advise on your particular application.

TABLE 8



	Code
Panel Mounting Clamp in Stainless Steel	Apply for Details
Pipe Mounting Clamp in Stainless Steel	
Approved IS Indicator in Hazardous Area	Specify in full
Instrument Valves	
Chemical Seal (Remote or direct)	04
Oxygen Service 2: Process (wetted) parts are cleaned for oxygen.	APPLY FOR DETAILS
Tagging – Variety of tagging methods are available	
Applies when no option is required and selection is made from SPECIAL ENGINEERING	00

## Special Engineering

To your individual requirements, where specified. For your convenience, enter your special listing in space provided.

TABLE 9



FEATURE	Code
PLEASE CONSULT DELTA SALES ENGINEERING	TBA

## Technical Specifications

### OUTPUT

4 to 20mA proportional to pressure, 2-wire

### POWER SUPPLY

12 to 38V DC at instrument terminals.  
Reverse polarity protected. Less than 0.01% per volt effect.

### ACCURACY

Less than  $\pm 0.15\%$  of URV\*, including combined effects of linearity, hysteresis and repeatability

### LONG TERM STABILITY

Less than  $\pm 0.15\%$  of URL\*, over a 6 month period.

### AMBIENT TEMPERATURE

-20 to +85°C (-4 to +185°F)

### PROCESS TEMPERATURE

-40 to +120°C (-40 to +240°F)

### COMPENSATED RANGE

-20 to +85°C (-4 to +185°F)

\*FOR DEFINITIONS SEE TABLE 5

### AMBIENT TEMPERATURE

Less than  $\pm 0.025\%$  of URL\*, for every 1 deg C (1.8 deg F) change in ambient temperature.

### VIBRATION TOLERANCE

5g peak to peak sinusoidal at 5 to 200Hz.

### RADIO FREQUENCY INTERFERENCE EFFECT

Induced error shall not exceed  $\pm 0.15\%$  of URL\*, when tested to IEC 801-3 severity level 3 (10v/m) with cover closed)

### WARM-UP TIME

250 milliseconds typical

### RESPONSE TIME

150 milliseconds typical

### ADJUSTABILITY

Zero  $\pm 5\%$  Full range  
Range 4:1 turndown.

## Operation / Installation

### WIRING AND ADJUSTMENT

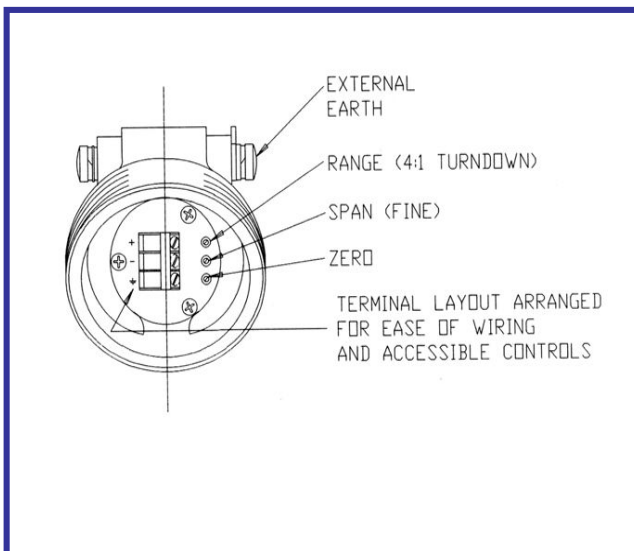

### VOLTAGE v LOAD

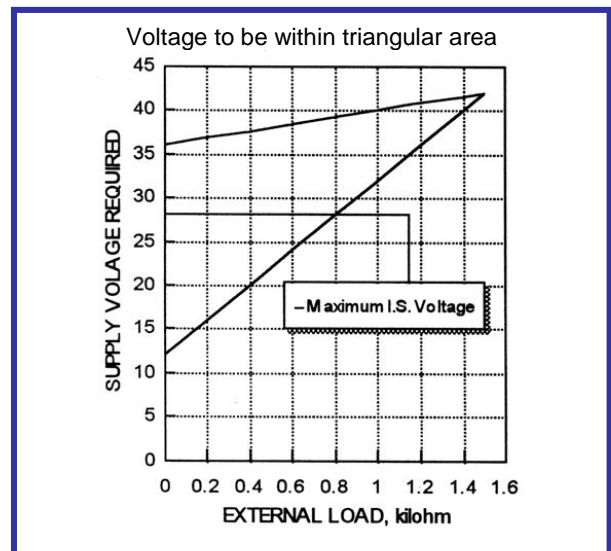

## Approvals

### CENELEC/BASEEFA (EECS)

Intrinsically Safe.  
BASEEFA certified to CENELEC EN 50 014 and EN50 020 for use in Zone 1 hazardous areas.

Enclosure Codes 4 and all ranges.



Certificate No ITS03ATEX21062X  
System Certificate

### FACTORY MUTUAL RESEARCH CORPORATION

FM Approved for use in Divisions 1 and 2.



Enclosure Code F; see Table 5 for limitations on ranges.

File number 4V3A8.AX & 2X6A6.AX

### CENELEC/BASEEFA



Flameproof / Weatherproof  
BASEEFA certified to CENELEC EN 50 014 and EN50 018 for use in Zone 1 hazardous areas.

Enclosure Code R and all ranges 10 bar (160 psi) and above.

Certificate No BAS02ATEX2191

## Dimensions

### OUTLINE

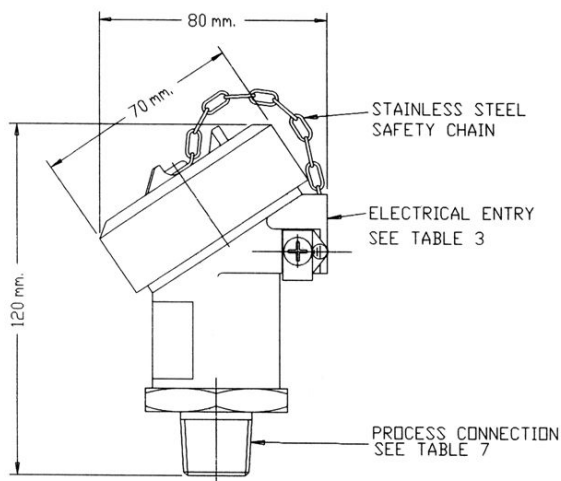

ALL DIMENSIONS mm (Inches)      WEIGHT:900g approx

### WALL MOUNTING BRACKET

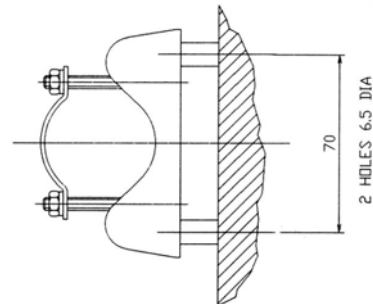

100g approx

### PIPE MOUNTING BRACKET

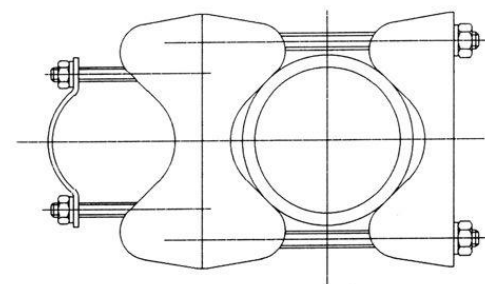

250g approx

*In the interest of development and improvement Delta Controls Ltd, reserve the right to amend, without notice, details contained in this publication.  
No legal liability will be accepted by Delta Controls Ltd for any errors, omissions or amendments.  
We retain the right to supply Hastelloy Sensors as an alternative. If you require Stainless Steel please confirm with sales department*



Delta Controls Limited

Island Farm Avenue, West Molesey, Surrey KT8 2UZ, UK.

T+44 (0)20 8939 3500 F+44 (0)20 8783 1163 E [sales@delta-controls.com](mailto:sales@delta-controls.com) W [www.delta-controls.com](http://www.delta-controls.com)



FM06720