

Main features

- 50 to 750 mm. stroke
- Mechanical fixing and selfaligning linkage using 2 ball-joints
- Maximum angular movement up to $\pm 30^\circ$
- Independent linearity $\pm 0,05\%$
- Repetibility 0,01 mm.
- Infinite resolution
- No variation of electrical signal outside theoretical electrical stroke
- Displacement speed up to 5 m/s
- Working temperature: $-30\dots+100^\circ\text{C}$
- Electrical connections:
 PC H 3-pole connector
 PC M 4-pole connector to standard DIN43650-ISO4400
 PC B 5-pole connector (DIN43322)
 PC F 3-pole screened cable (1 m length)
- Life duration: $> 25 \times 10^6$ meters or $> 100 \times 10^6$ operations, whichever is the smaller (within C.E.U.)
- Grade of protection IP65
- Suitable for use in explosive environments with presence of gas (groups IIA, IIB, IIC) and combustible powders. Standards for simple device:
 ATEX CEI EN 50020 2003 - paragraph 5.4 a



TECHNICAL DATA

Useful electrical stroke (C.E.U.)	50/100/130/150/175/200/225/275/300/360/375/400/450/500/600/750
Independent linearity (within C.E.U.)	$\pm 0,05\%$
Displacement speed	≤ 5 m/s
Displacement force	≤ 10 N
Vibrations	5...2000Hz, $A_{max} = 0,75$ mm $a_{max.} = 20$ g
Shock	50 g, 11ms.
Tolerance on resistance	$\pm 20\%$
Recommended cursor current	$< 0,1$ μA
Maximum cursor current	10mA
Maximum applicable voltage	60V
Electrical isolation	$> 100\text{M}\Omega$ at 500V \sim , 1bar, 2s
Dielectri strength	< 100 μA at 500V \sim , 50Hz, 2s, 1bar
Dissipation at 40°C (0W at 120°C)	3W
Actual Temperature Coefficient of the output voltage	$< 1,5$ ppm/ $^\circ\text{C}$
Working temperature	$-30\dots+100^\circ\text{C}$
Storage temperature	$-50\dots+120^\circ\text{C}$
Case material	Anodised aluminium Nylon 66 G25
Control rod material	Stainless steel AISI 303
Fixing	2 selfloading and selfaligning ball-joints

MECHANICAL DIMENSIONS

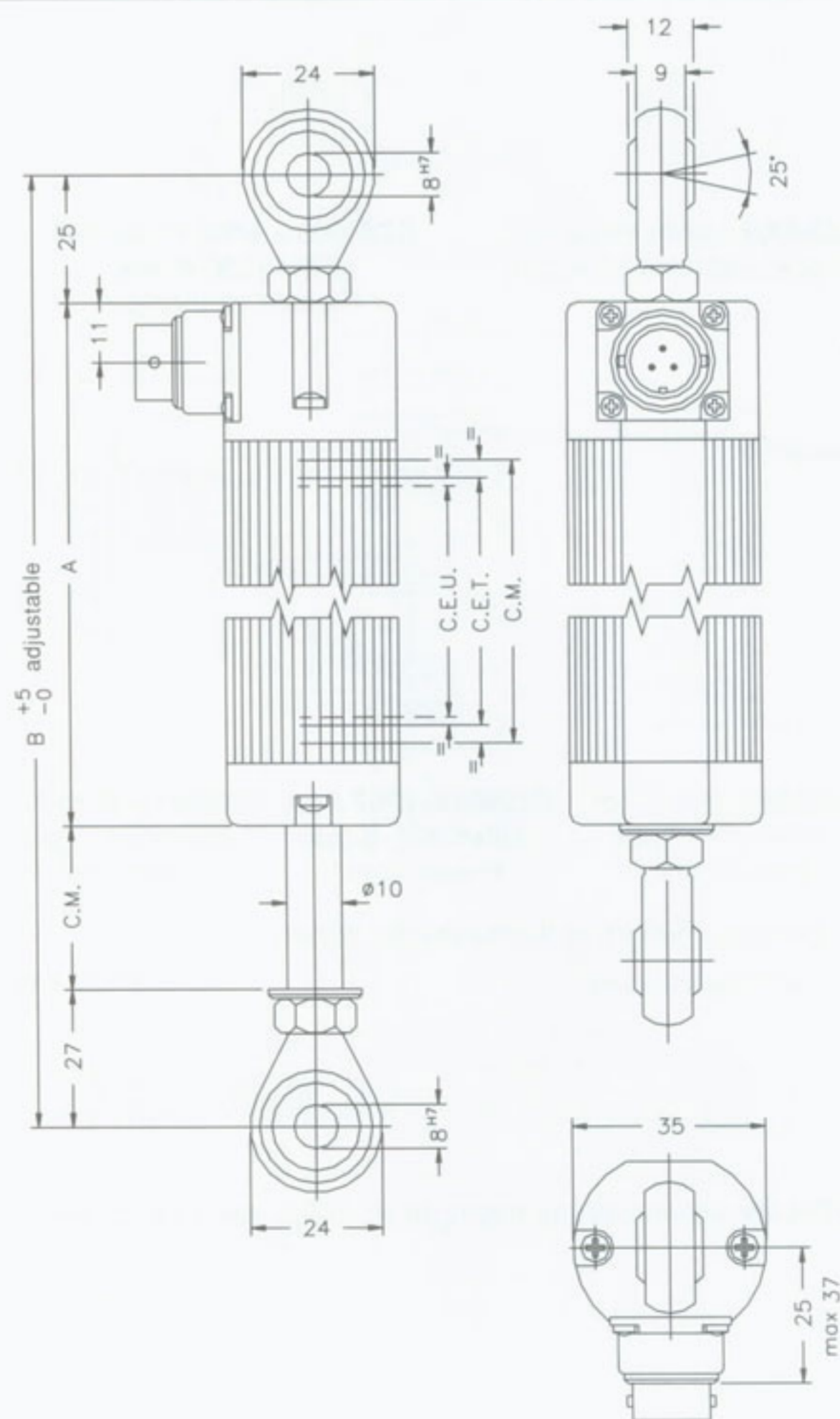

Important: all the data reported in the catalogue linearity, lifetime, temperature coefficient are valid for a sensor utilization as a ratiometric device with a max current across the cursor $I_c \leq 0.1$ μA .

MECHANICAL / ELECTRICAL DATA

MODEL		50	100	130	150	175	200	225	275	300	360	375	400	450	500	600	750	
Useful electrical stroke (C.E.U.) +3/-0	mm	50	100	130	150	175	200	225	275	300	360	375	400	450	500	600	750	
Theoretical electrical stroke (C.E.T.) ± 1	mm	C.E.U. + 3					C.E.U. + 4					364	380	406	457	508	609	762
Resistance (C.E.T.)	kΩ	5					5					5	5	5	5	5	5	10
Mechanical stroke (C.M.)	mm	C.E.U. + 9					C.E.U. + 10					370	386	412	463	518	619	772
Case length (A)	mm	C.E.U. + 129					C.E.U. + 130					496	512	538	589	664	765	918
Min. distance between ball-joints (B)	mm	C.E.U. + 181					C.E.U. + 182					547,5	564	590	641	716	817	970

ELECTRICAL CONNECTIONS

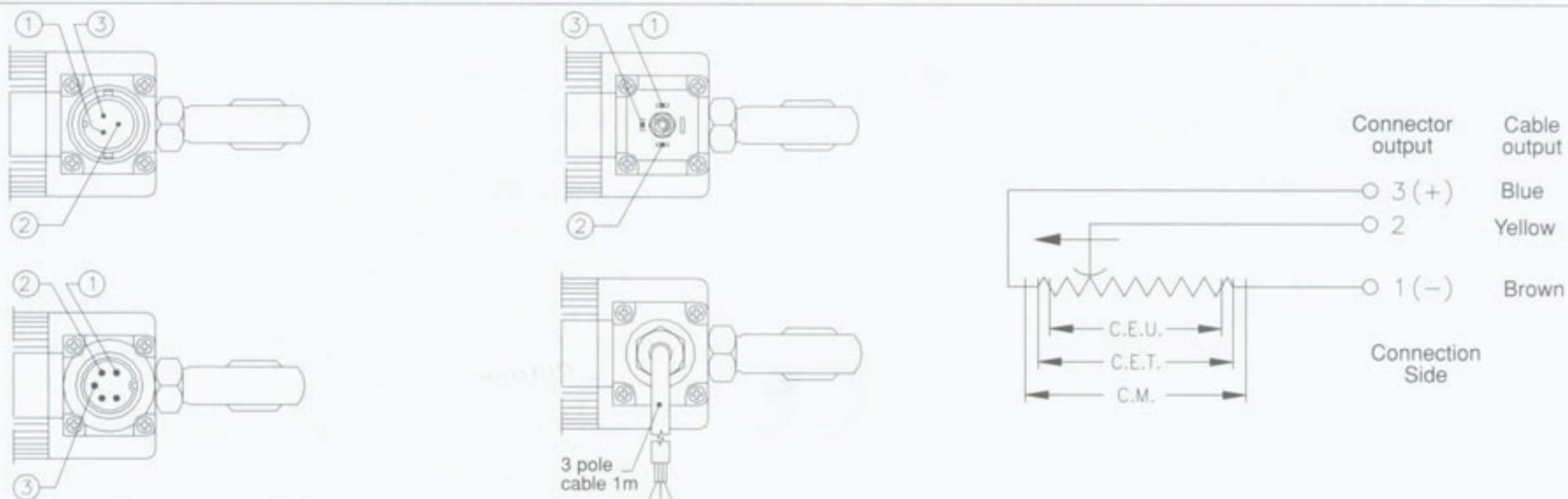

OPTIONAL ACCESSORIES

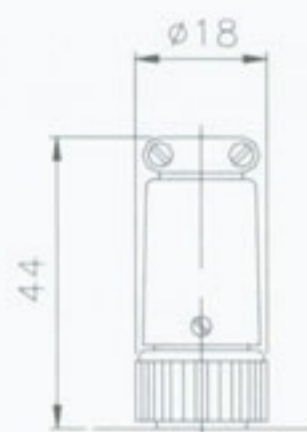

CON002 - IP40 Prot.
(3 Pole Female conn.)

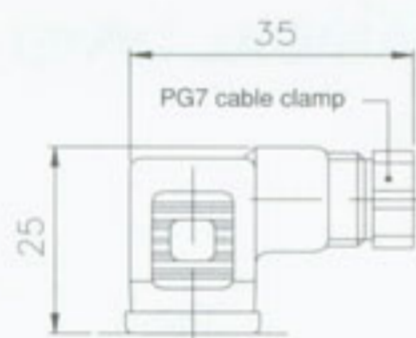

CON008 - IP65 Prot.
(DIN43650 4 pole Female conn.)

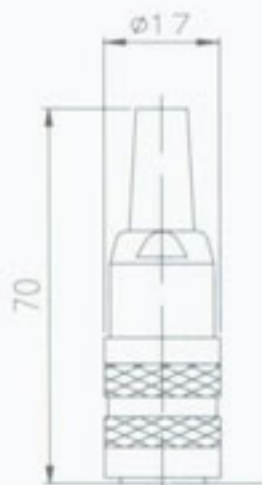

CON011 - IP40 Prot.
(DIN43322 5 pole Female conn.)

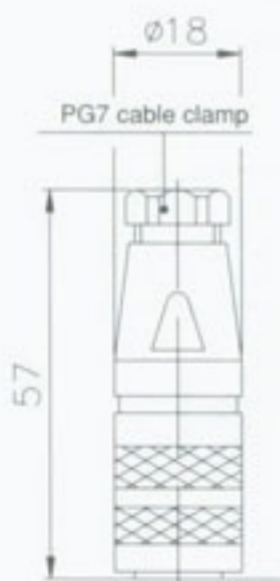

CON012 - IP67 Prot.
(DIN43322 5 pole Female conn.)

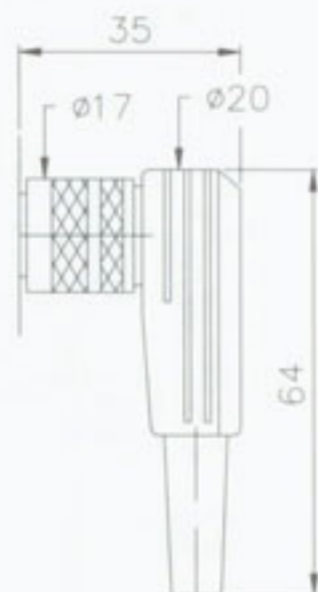

CON013 - IP40 Prot.
(DIN43322 5 pole Female conn.)

Extraction length of the connector 10 mm.

ORDER CODE

Displacement transducer

PC

3-pole connector output	H
4-pole connector output DIN43650 ISO4400	M
5-pole connector output DIN45322	B
3-pole PVC cable output 3x0,25 1m	F

Model

If requested, it is possible to supply models with non-standard mechanical and/or electrical features.

Example: PC - M - 275

Displacement transducer model PC, 4 pole connector output DIN43650 - ISO 4400, useful electrical stroke (C.E.U.) 275mm.