

Mobrey Squitch-2

Ultrasonic liquid level switch



- No moving parts
- Simple 2 wire installation
- Mount in any position
- LED status indicator
- 316 Stainless steel wetted parts
- Works in most clean liquids

Options

Squitch is available with a variety of mounting options including threads and hygienic couplings. See ordering information inside for full details.

Description

A compact, self contained ultrasonic liquid level switch with 316 stainless steel wetted parts and 240V switching capability. Squitch is a 2 wire product - that is, it requires only 2 electrical connections, using standard instrument wire.

The Squitch is connected in series with the load (contactor, starter, relay, etc.) and acts as a simple switch, operated by liquid presence.

Squitch may also be interfaced directly to a PLC using simple instrument cable. For this purpose, a PLC terminal is provided in the housing.

Operation

Squitch is an ultrasonic gap sensor switch. When a liquid fills the sensor gap an ultrasonic signal is transmitted across the gap and the presence of liquid is signalled. When the sensor gap is filled with air there is no signal transmitted and a "dry" state is signalled.

Squitch may be set on site with a selector switch to energise on either wet or dry.

When Squitch is 'off' a small current of less than 4.5mA is drawn through the load and a red LED viewed through a window in the end cover will flash approximately once per second.

When Squitch is 'on', the full load current (0.5A max.) flows, and the L.E.D is on constantly. In this way there is always an indication that Squitch is "alive and well".

Squitch may be installed in any position in the vessel.

Squitch should not be used in aerated liquids such as carbonated drinks or in liquids with high concentrations of suspended solids such as liquid chocolate.

Level

Specification

Wetside material	Stainless steel 316
Dryside material	Glass filled nylon, housing yellow, end cap black
Protection class	IP66/IP67 / NEMA 4X Housing is rotatable 330° on sensor
Max. operating pressure	70 bar between - 40°C to + 50°C / 1015psi between - 40°F to + 122°F 52 bar at +125°C / 754psi at +257°F
Operating temp	-40°C to +125°C / -40°F +257°F wetside
Ambient temp	-40°C to +50°C / - 40°F to +122°F (upto 125°C / 257°F on wetside)
Power supply	24V - 240V DC or AC (50-60Hz)
Cable entry	Via cable gland supplied
Terminals	2.5mm ² / 14 AWG wire size
Max. switched load	500mA continuous
Min. switched load	7.5mA continuous (see voltage drop)
Max. peak load	5 A for 40ms max
Current drawn: load off:	<4.5mA continuous
Voltage drop	4.5V @ 500mA 10V @ 7.5mA
Time delay/response	1 S wet to dry 150mS dry to wet (water)
Switching hysteresis	± 1mm / ± 0.04"
Viscosity	5000cs max (at 25°C / 77°F)

Dimensions

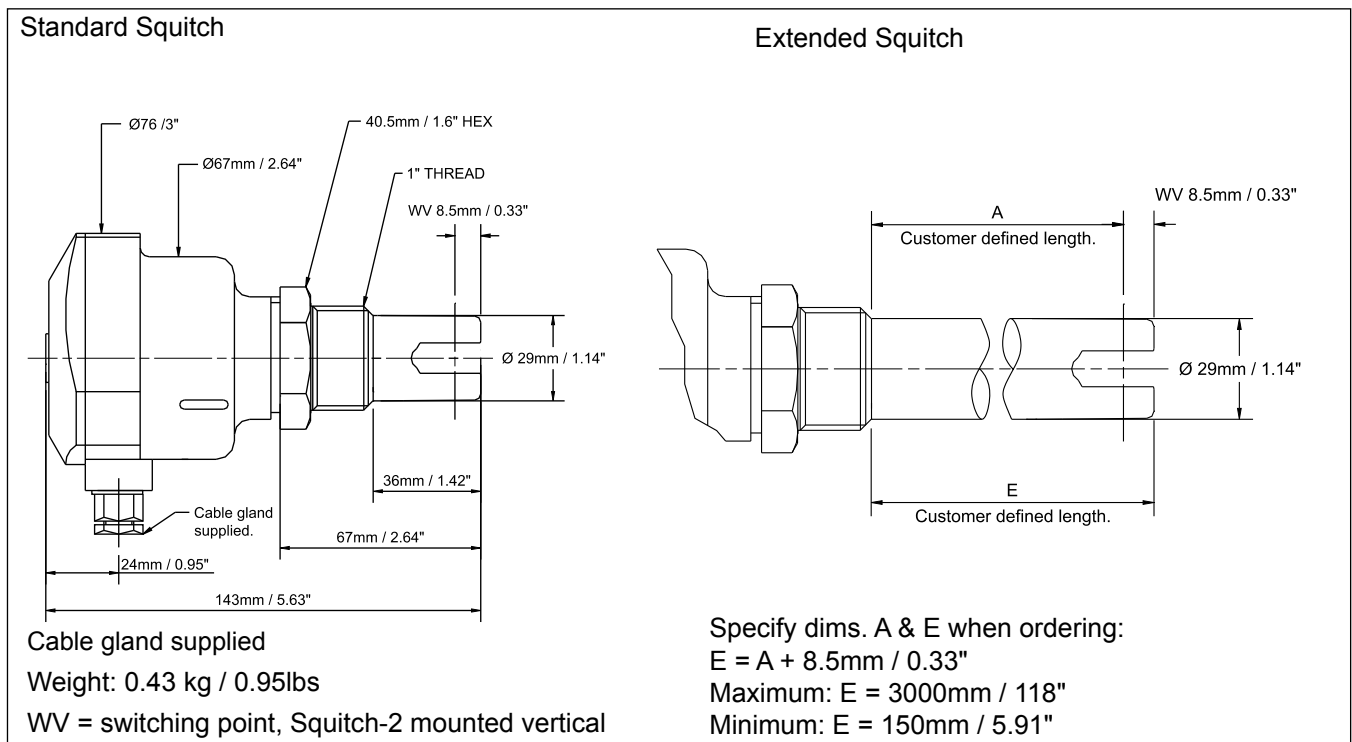

Specification sheet

IP207
February 2007

Level

Ordering Information

Code	Product
8	Squitch
Code	Size
3	1"
5	2" (or 51mm): use with Tri-clover clamp fitting only
Code	Fitting
0	BSPT thread (1" only)
4	BSPP Outside fitting (1" only)
5	NPT Outside fitting (1" only)
7	Tri-Clover clamp (2" only)
Code	Material
SD	316 Stainless steel
Code	Enclosure
S	Yellow Squing housing
Code	Use
0	Safe area use only (see note below)
Code	Output
0	Direct load switching (24-240V ac/dc)
Code	Finish
0	Electropolish or glass bead on flanged/ extended length models
Code	Material Certs :
0	Typical (on request only)
Code	Length
E****	Extended length. (3000mm / 118" max.) 1" & flange only
L	Fixed length. E = 92mm / 3.6"

8	3	0	SD	S	0	0	0	0	0	E2000	Typical part number
---	---	---	----	---	---	---	---	---	---	-------	---------------------

Adjustable gland kit

An adjustable gland is available to allow site adjustment of the switching level for top mounted extended length Squitch. The gland is ordered as a separate item as below and may be used with any Squitch with extended length greater than 300mm / 12".

Material:	Body	316 Stainless steel
	Seal	Silicone rubber
Maximum pressure	1.3 bar / 18.9 psi	
Maximum temperature	125°C / 257°F	

Order part number:

SK304	1.5" BSPP thread
SK462	1.5" NPT thread

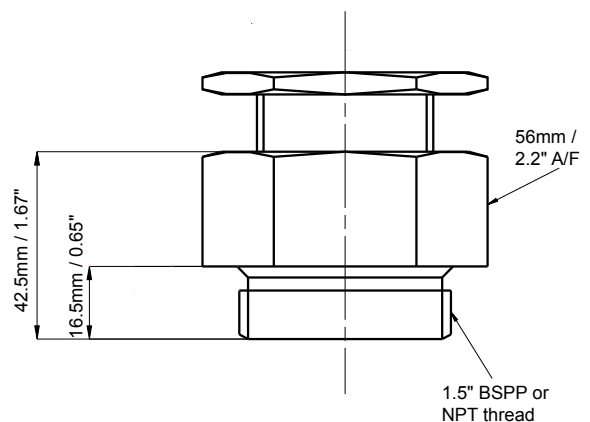

Level

Accessories

Adjustable clamp gland Maximum operating pressure: 1.3 bar / 19psi Maximum operating temperature: 125°C / 257°F	SK304 / SK462 For use with 1" thread extended length Squitch Manufactured from 316 stainless steel with a silicone rubber clamp seal. Allows Squitch to be adjusted to optimum operating level and clamped in place.
Tri-clover mounting kit Maximum operating pressure: 30 bar / 435psi Maximum operating temperature: 90°C / 194°F	SK266 For use with Tri-clover Squitch type 857 Comprises vessel fitting and clamp ring in 316SS plus NBR Nitrile rubber seal

Note: Standard Squitch can NOT be used in a hazardous area. For hazardous area use, select the Mobrey Electrosensor model (332SDS0 typical model number) from the comprehensive range of gap sensor systems detailed in data sheet IP201.

Mobrey Measurement Limited
 Authorised distributor: Ward Industries Limited
 Tel: +44 (0) 1933 624963 Fax: +44 (0) 1933 625458
 E-mail: sales@wardindustries.co.uk Web: www.wardindustries.co.uk

The Emerson logo is a trade mark and service mark of Emerson Electric Co.
 Rosemount is a registered trademark of Rosemount Inc.
 Mobrey is a registered trademark of Mobrey Ltd.
 All other marks are the property of their respective owners
 We reserve the right to modify or improve the designs or specifications of product and services at any time without notice.

International:
Emerson Process Management
Mobrey Measurement
 158 Edinburgh Avenue, Slough,
 Berks UK SL1 4UE
 T +44 (0)1753 756600
 F +44 (0)1753 823589
 www.mobrey.com

Americas:
Emerson Process Management
Rosemount Inc.
 8200 Market Boulevard
 Chanhassen, MN USA 55317
 T (US) (800) 999-9307
 T (International) 952) 906-8888
 F (952) 949-7001
 www.rosemount.com

