



**$\frac{1}{16}$ -DIN  
DIGITAL INDICATOR**

**Product Manual**

# How to use this manual

## VOLUME I OPERATING INSTRUCTIONS

<b>SECTION 1</b>	Process variable and alarm status display Input over-range/under-range indication Sensor Break indication Viewing the Hardware Definition Code
<b>SECTION 2</b>	Setting up the Alarm values Selecting input scale range (linear input only) Setting up the recorder output option

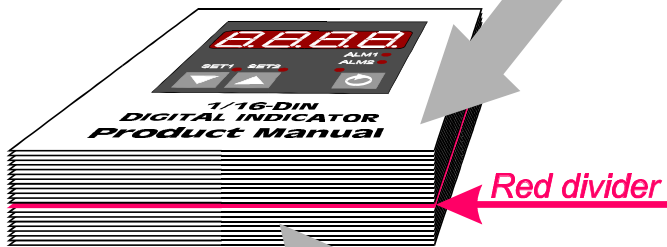

## VOLUME II INSTALLATION & CONFIGURATION INSTRUCTIONS

<b>SECTION 1</b>	Panel-mounting and wiring-up the Indicator
<b>SECTION 2</b>	Selecting the required input/output type(s)
<b>SECTION 3</b>	Matching software to hardware fitted Selecting input range and alarm type(s)
<b>APPENDIX A</b>	Product specification



*The functions described in Volume II must be performed only by personnel who are trained, equipped and authorised to do so.*

# **$\frac{1}{16}$ -DIN DIGITAL INDICATOR**

## **PRODUCT MANUAL**

### **VOLUME I OPERATING INSTRUCTIONS**



In normal operation, the operator must not remove the Indicator from its housing or have unrestricted access to the rear terminals, as this would provide potential contact with hazardous live parts.

Installation and configuration must be undertaken by technically-competent servicing personnel. This is covered in Volume II of this manual.

### **Contents**

<b>1</b>	<b>OPERATOR MODE</b>	<b>1-1</b>
1.1	INTRODUCTION	1-1
1.2	AVAILABLE DISPLAYS	1-1
1.3	OVER-RANGE/UNDER-RANGE DISPLAYS	1-2
1.4	SENSOR BREAK INDICATION	1-2
1.5	VIEWING THE HARDWARE DEFINITION CODE	1-2
<b>2</b>	<b>SET UP MODE</b>	<b>2-1</b>
2.1	ENTRY INTO SET UP MODE	2-1
2.1.1	Remote Lock Option Not Fitted or Fitted and Set OFF	2-1
2.1.2	Remote Lock Option Fitted and Set ON	2-1
2.1.3	All Set Up Parameters at Default Values	2-1
2.2	SET UP MODE PARAMETERS	2-2

2.2.1	Alarm 1 Value	2-3
2.2.2	Alarm 2 Value	2-3
2.2.3	Linear Input Scale Range Maximum	2-3
2.2.4	Linear Input Scale Range Minimum	2-4
2.2.5	Recorder Output Scale Maximum	2-4
2.2.6	Recorder Output Scale Minimum	2-4
2.3	EXIT FROM SET UP MODE	2-4
2.3.1	Remote Lock Option Not Fitted or Fitted and Set OFF	2-4
2.3.2	Remote Lock Option Fitted and Set ON	2-5

# 1 OPERATOR MODE

## 1.1 INTRODUCTION

The Operator Mode is the normal mode of the Indicator. The front panel displays, indicators and keys are shown below.

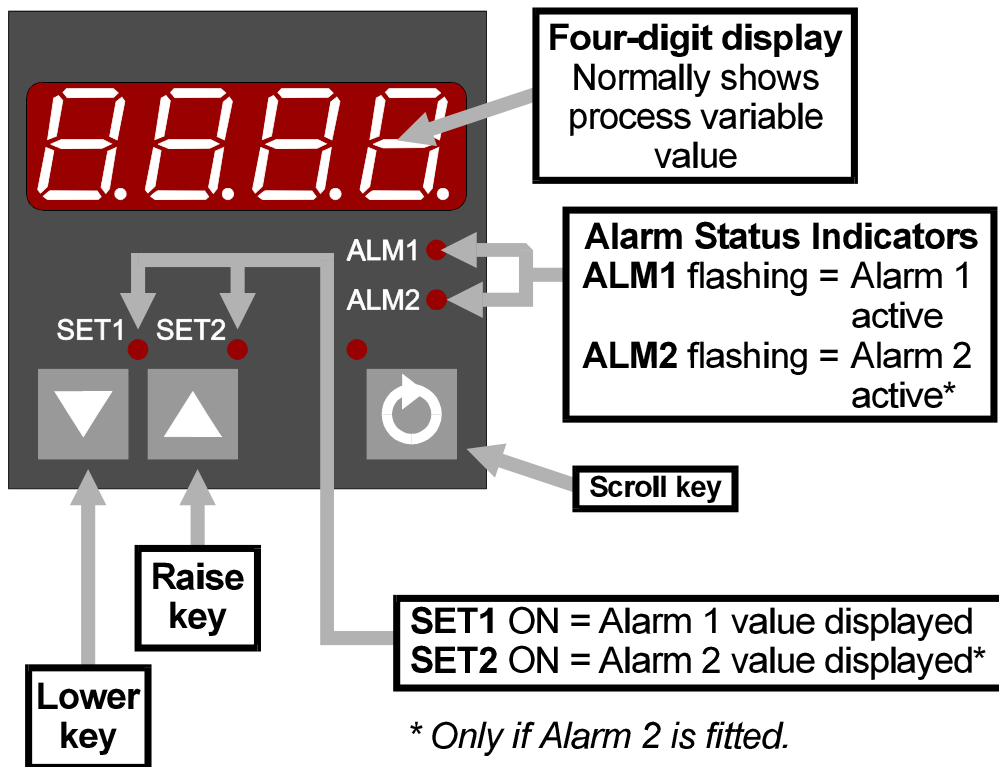

## 1.2 AVAILABLE DISPLAYS

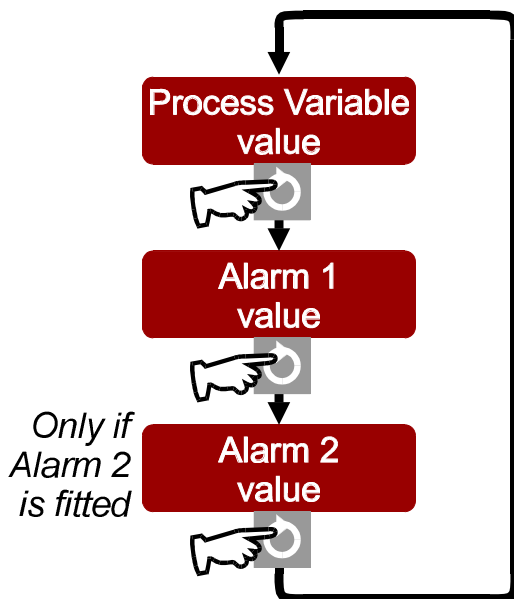

NOTE: In Operator Mode, alarm values can be viewed only. They can be adjusted only in Set Up Mode (see Section 2).

For descriptions of the various types of alarm available, see Figure 2-2.

### 1.3 OVER-RANGE/UNDER-RANGE DISPLAYS

If the process variable attains a value higher than the input scale maximum limit (over-range) or lower than the input scale minimum limit (under-range), the four-digit display will show the appropriate one of the following:



Over-range



Under-range

### 1.4 SENSOR BREAK INDICATION

If a break is detected in the sensor circuit, the four-digit display will show:



The reaction of the alarms to a sensor break is dependent upon the input type.

### 1.5 VIEWING THE HARDWARE DEFINITION CODE

To view the current Hardware Definition Code setting (indicating input/output types) and Hardware Option setting (indicating the option(s) fitted):

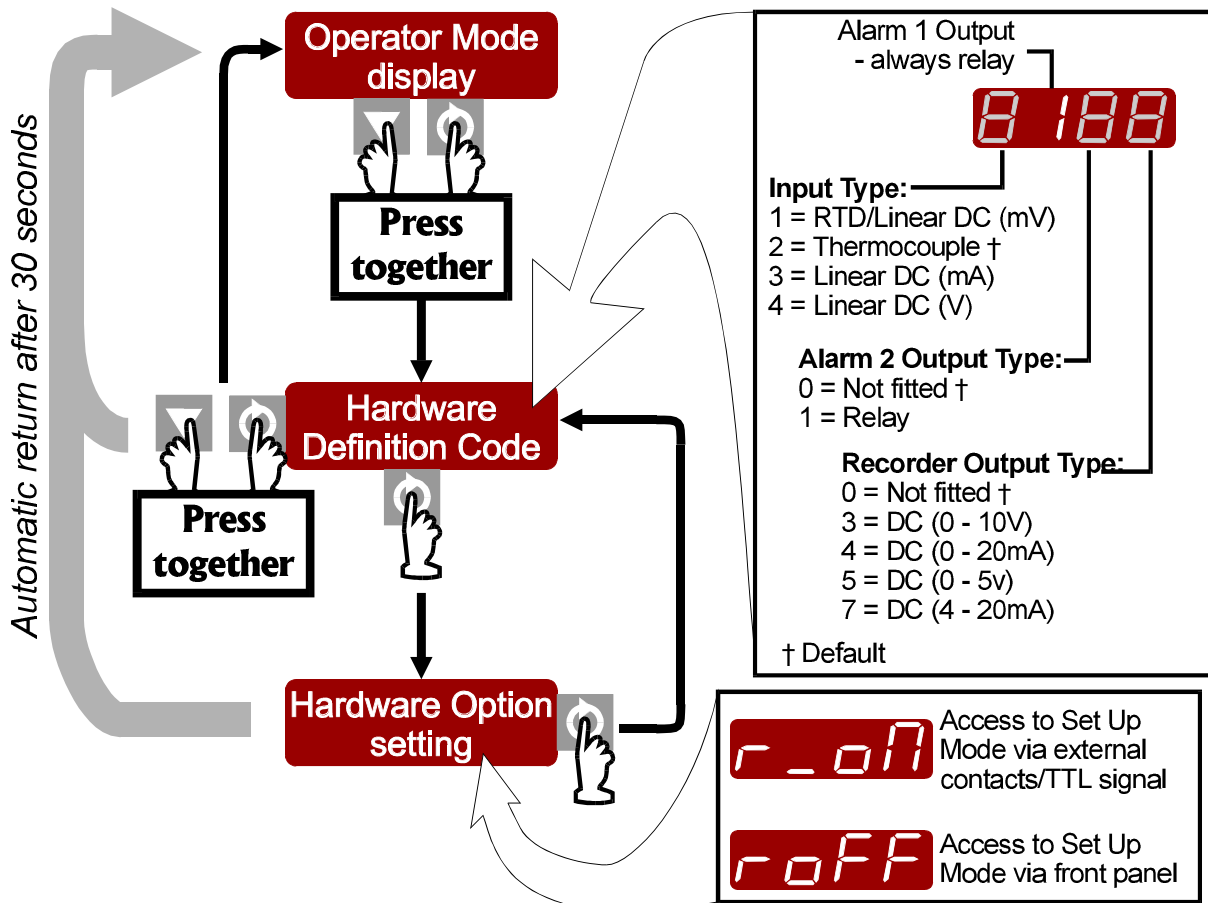

## 2 SET UP MODE

### 2.1 ENTRY INTO SET UP MODE

#### 2.1.1 Remote Lock Option Not Fitted or Fitted and Set OFF

*Instrument in Operator Mode*

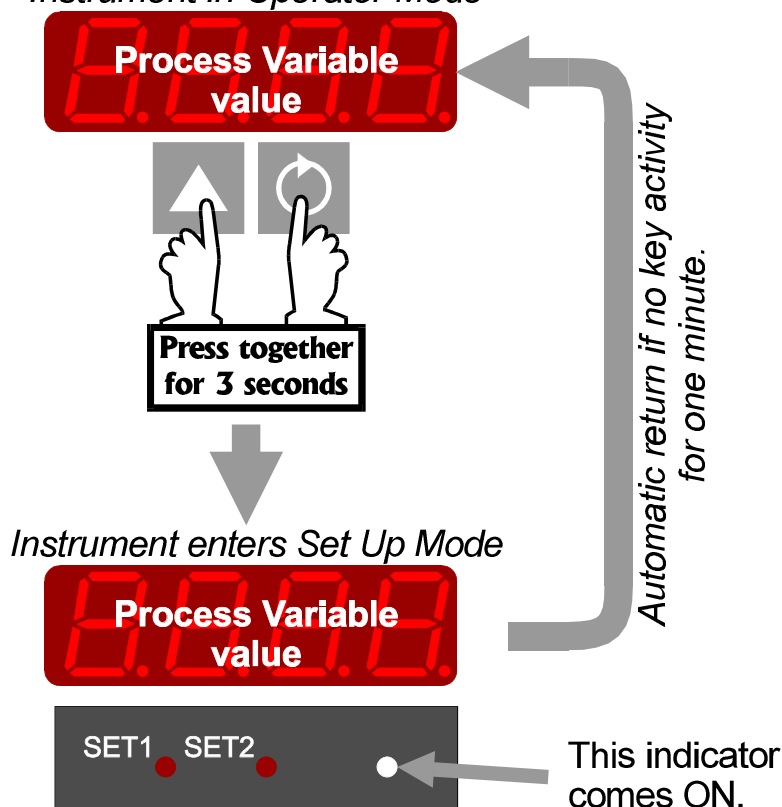

#### 2.1.2 Remote Lock Option Fitted and Set ON

It is not possible to enter into/exit from Set Up Mode via the front panel. Access to this mode is controlled by the Remote Lock Option. The no key activity automatic return to Operator Mode is inoperative.

#### 2.1.3 All Set Up Parameters at Default Values

If the four-digit display shows:



(i.e. all decimal point positions illuminated), this indicates that one or more of the critical configuration parameters - typically input range - have been altered in value/setting and, as a consequence, all Set Up Mode parameters have been automatically set to their default values/settings. To clear this display, simply alter the value/setting of any Set Up Mode parameter (see below). *It is recommended that all configuration parameters be set as required before any adjustment is made to the Set Up Mode parameters.*



Table 2-1 Set Up Mode Parameters

Parameter	Adjustment Range	Default
Alarm 1 value	Range Min. To Range Max.	Range Max. (Process High) Range Min. (Process Low)
Alarm 2 value <sup>1</sup>	Range Min. To Range Max.	Range Max. (Process High) Range Min. (Process Low)
Linear Input Decimal Point Position <sup>2</sup>	0 (XXXX), 1 (XXX.X), 2 (XX.XX) or 3 (X.XXX)	1 (XXX.X)
Linear Input Scale Range Maximum <sup>2</sup>	-1999 to 9999	1000
Linear Input Scale Range Minimum <sup>2</sup>	-1999 to 9999	0000
Recorder Outout Scale Maximum <sup>3</sup>	-1999 to 9999	Range Max.
Recorder Output Scale Minimum <sup>3</sup>	-1999 to 9999	Range Min.

## NOTES

1. Appears only if Alarm 2 is fitted/configured.
2. Applicable only if a DC Linear input is fitted.
3. Applicable only if the Recorder Output option is fitted.

### 2.2.1 Alarm 1 Value

If Alarm 1 is selected to be a Process High alarm, this defines the process variable value at or above which Alarm 1 will be active. If Alarm 1 is selected to be a Process Low alarm, this defines the process variable value at or below which Alarm 1 will be active. Alarm operation is illustrated in Figure 2-2.

### 2.2.2 Alarm 2 Value

If Alarm 2 is selected to be a Process High alarm, this defines the process variable value at or above which Alarm 2 will be active. If Alarm 2 is selected to be a Process Low alarm, this defines the process variable value at or below which Alarm 2 will be active. Alarm operation is illustrated in Figure 2-2.

### 2.2.3 Linear Input Scale Range Maximum

This parameter defines the scaled input value when the process variable input is at its maximum value. The decimal point position as defined by Linear Input Decimal Point Position. This parameter can be set to a value less than (but not equal to) Linear Input Scale Range Minimum, in which case the sense of the input is reversed.

## 2.2.4 Linear Input Scale Range Minimum

This parameter defines the scaled input value when the process variable input is at its minimum value. The decimal point position as defined by Linear Input Decimal Point Position). This parameter can be set to a value greater than (but not equal to) Linear Input Scale Range Maximum, in which case the sense of the input is reversed.

## 2.2.5 Recorder Output Scale Maximum

This parameter defines the value of process variable at which the Recorder Output reaches its maximum value; for example, for a 0 - 5V Recorder Output, this value corresponds to 5V. The decimal point position for the Recorder Output is always the same as that for the process variable input range.

NOTE: If this parameter is set to a value less than that for the Recorder Output Scale Minimum (see Subsection 2.2.6), the relationship between the process variable/setpoint value and the Recorder Output is reversed.

## 2.2.6 Recorder Output Scale Minimum

This parameter defines the value of the process variable at which the Recorder Output reaches its minimum value; for example, for a 0 - 5V Recorder Output, this value corresponds to 0V. The decimal point position for the Recorder Output is always the same as that for the process variable input range.

NOTE: If this parameter is set to a value greater than that for the Recorder Output Scale Maximum (see Subsection 2.2.5), the relationship between the process variable value and the Recorder Output is reversed.

## 2.3 EXIT FROM SET UP MODE

### 2.3.1 Remote Lock Option Not Fitted or Fitted and Set OFF

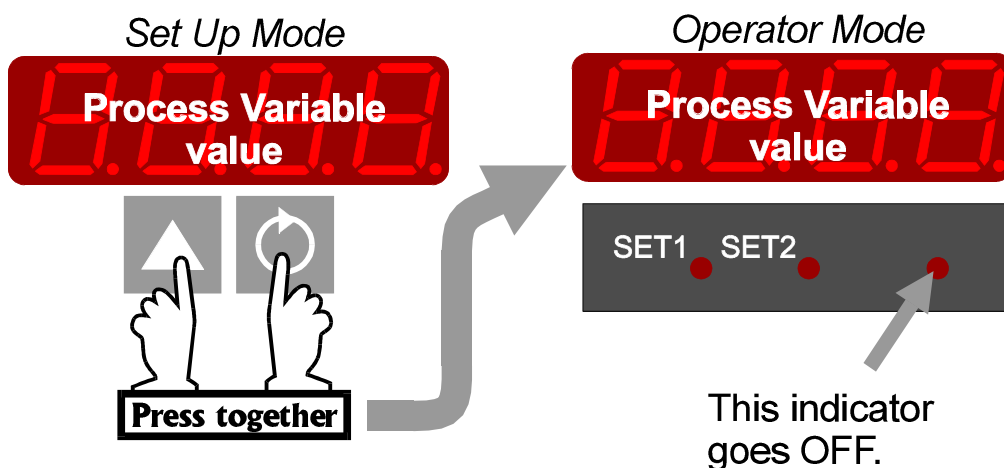

### 2.3.2 Remote Lock Option Fitted and Set ON

It is not possible to exit from Set Up Mode from the front panel. Exit from this mode is controlled by the Remote Lock Option.

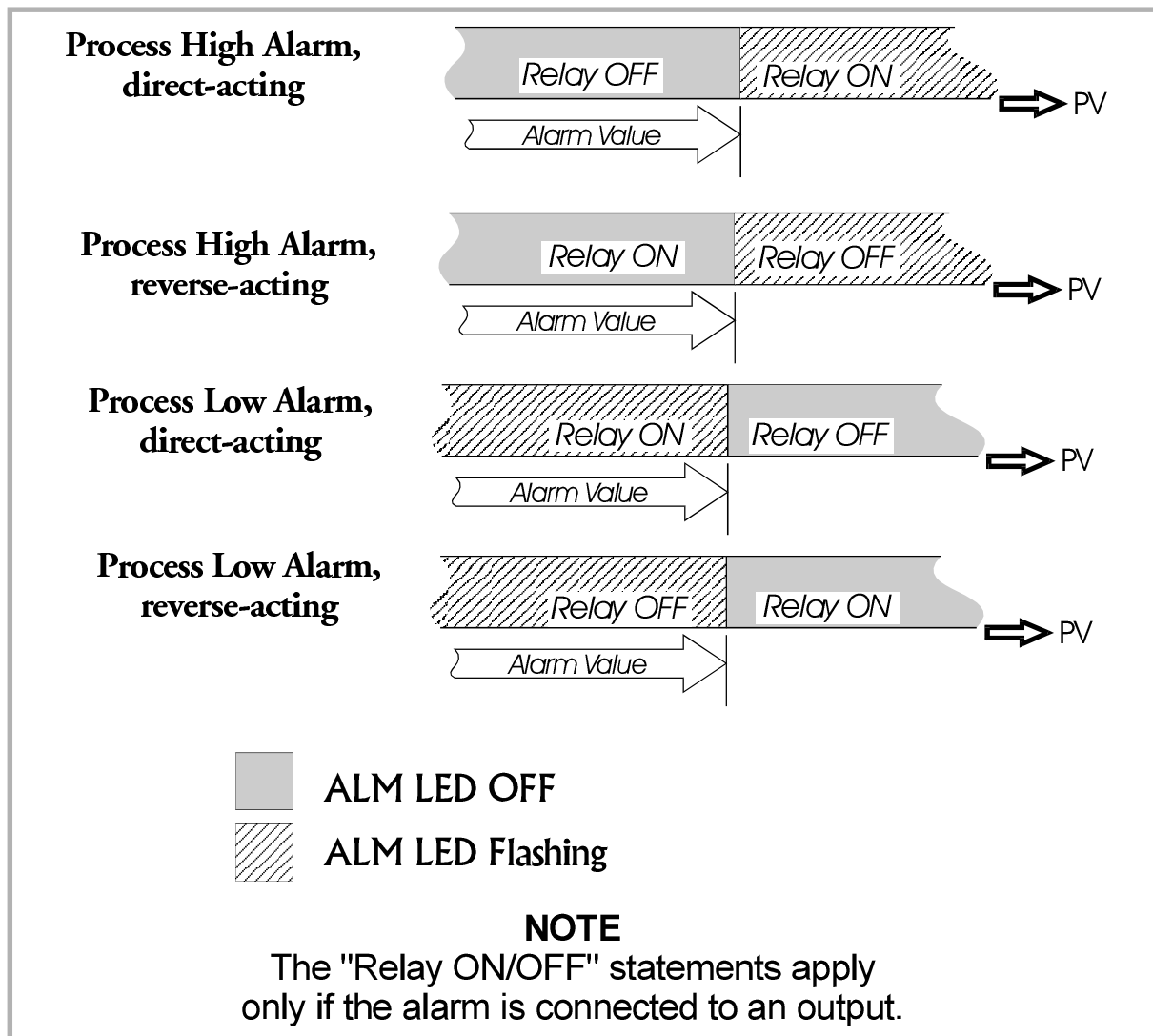

Figure 2-2 Alarm Operation

# **$\frac{1}{16}$ -DIN DIGITAL INDICATOR**

## **PRODUCT MANUAL**

### **VOLUME II INSTALLATION & CONFIGURATION INSTRUCTIONS**



The procedures described in this Volume must be undertaken only by technically-competent servicing personnel.

## **Contents**

<b>1</b>	<b>INSTALLATION</b>	<b>1-1</b>
1.1	UNPACKING PROCEDURE	1-1
1.2	PANEL-MOUNTING	1-1
1.3	CONNECTIONS AND WIRING	1-3
1.3.1	Mains (Line) Input	1-4
1.3.2	24V (Nominal) AC/DC Supply	1-4
1.3.3	Thermocouple Input	1-4
1.3.4	RTD Input	1-4
1.3.5	Linear Input	1-5
1.3.6	Set Up Mode Remote Lock (Option)	1-5
1.3.7	Relay Outputs	1-5
1.3.8	DC Output (Recorder Output)	1-5
<b>2</b>	<b>INTERNAL LINKS AND SWITCHES</b>	<b>2-1</b>
2.1	REMOVING THE INSTRUMENT FROM ITS HOUSING	2-1
2.2	REMOVING/REPLACING THE ALARM 2/RECORDER OUTPUT OPTION PCBs	2-3

2.3	REMOVING/REPLACING THE SET UP MODE REMOTE LOCK OPTION PCB	2-3
2.4	REPLACING THE INSTRUMENT IN ITS HOUSING	2-4
2.5	SELECTION OF INPUT TYPE	2-4
2.6	ALARM 2 OUTPUT TYPE	2-5
2.7	RECORDER OUTPUT RANGE SELECTION	2-5
<b>3</b>	<b>CONFIGURATION MODE</b>	<b>3-1</b>
3.1	ENTRY INTO CONFIGURATION MODE	3-1
3.2	HARDWARE DEFINITION CODE	3-2
3.3	HARDWARE OPTION	3-3
3.4	INPUT RANGE	3-4
3.5	ALARM TYPE	3-4
3.6	EXIT FROM CONFIGURATION MODE	3-4
<b>APPENDIX A</b>	<b>PRODUCT SPECIFICATION</b>	<b>A-1</b>

# 1 INSTALLATION

## 1.1 UNPACKING PROCEDURE

1. Remove the instrument from its packing. The instrument is supplied with a panel gasket and push-fit fixing strap. Retain the packing for future use, should it be necessary to transport the instrument to a different site or to return it to the supplier for repair/testing.

2. Examine the delivered items for damage or deficiencies. If any is found, notify the carrier immediately.

## 1.2 PANEL-MOUNTING

The panel on which the instrument is to be mounted must be rigid and may be up to 6.0mm (0.25 inches) thick. The cut-out required for a single Digital Indicator is as shown in Figure 1-1.

The Digital Indicator is 110mm deep (measured from the rear face of the front panel). The front panel is 48mm high and 48mm wide. When panel-mounted, the front panel projects 10mm from the mounting panel. The main dimensions of the instrument are shown in Figure 1-2.

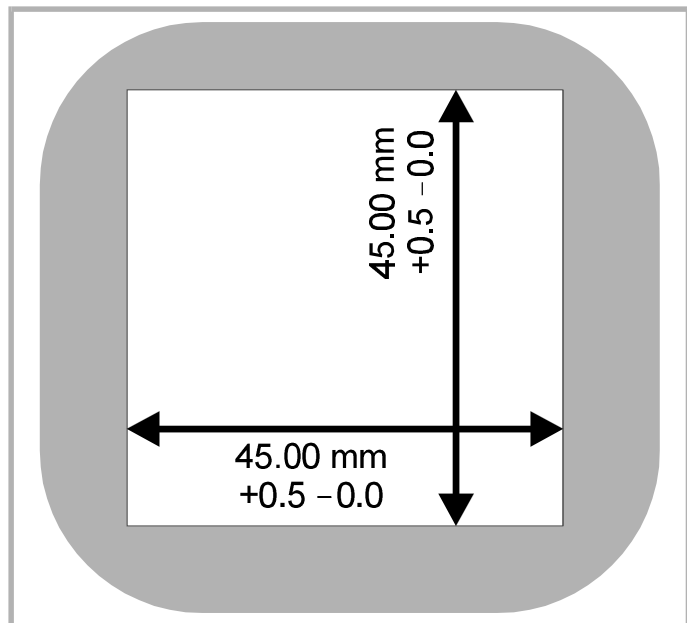

Figure 1-1 Panel Cut-out Dimensions

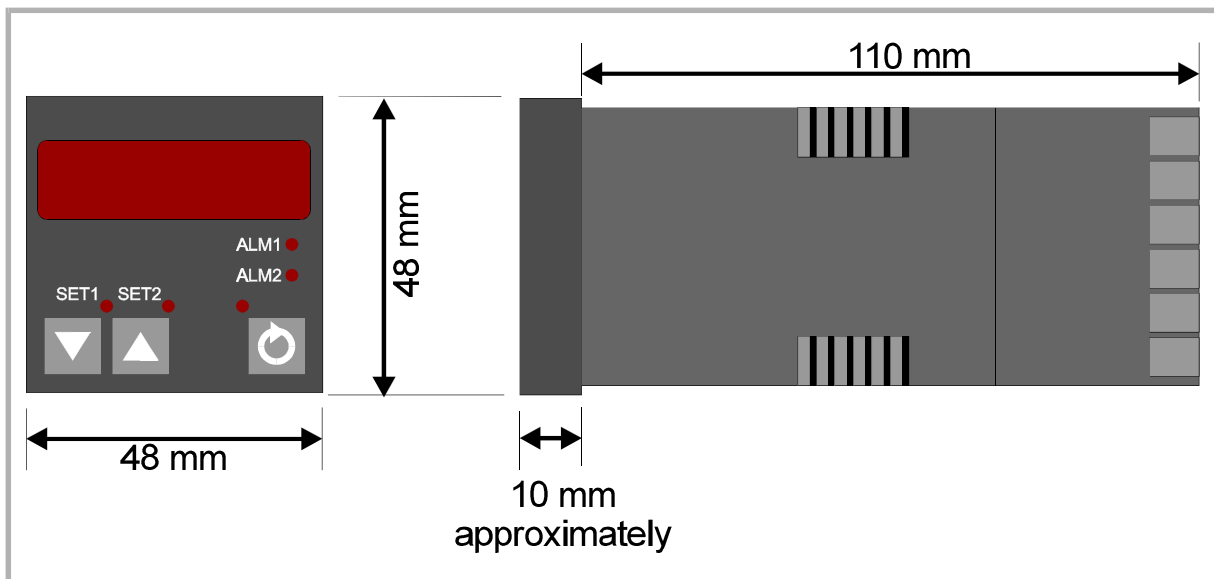

Figure 1-2 Main Dimensions

To panel-mount the instrument:

1. Insert the rear of the housing through the cut-out (from the front of the mounting panel) and hold the instrument lightly in position against the panel. Ensure that the panel gasket is not distorted and that the instrument is positioned squarely against the mounting panel. *Apply pressure to the front panel bezel only.*

**CAUTION:** Do not remove the panel gasket, as this may result in inadequate clamping of the instrument in the panel.

2. Slide the fixing strap in place (see Figure 1-3) and push it forward until it is firmly in contact with the rear face of the mounting panel (the tongues on the strap should have engaged in matching ratchet positions on the housing and the fixing strap springs should be pushing firmly against the mounting panel rear face).

Once the instrument is installed in its mounting panel, it may be subsequently removed from its housing, if necessary, as described in Subsection 2.1.

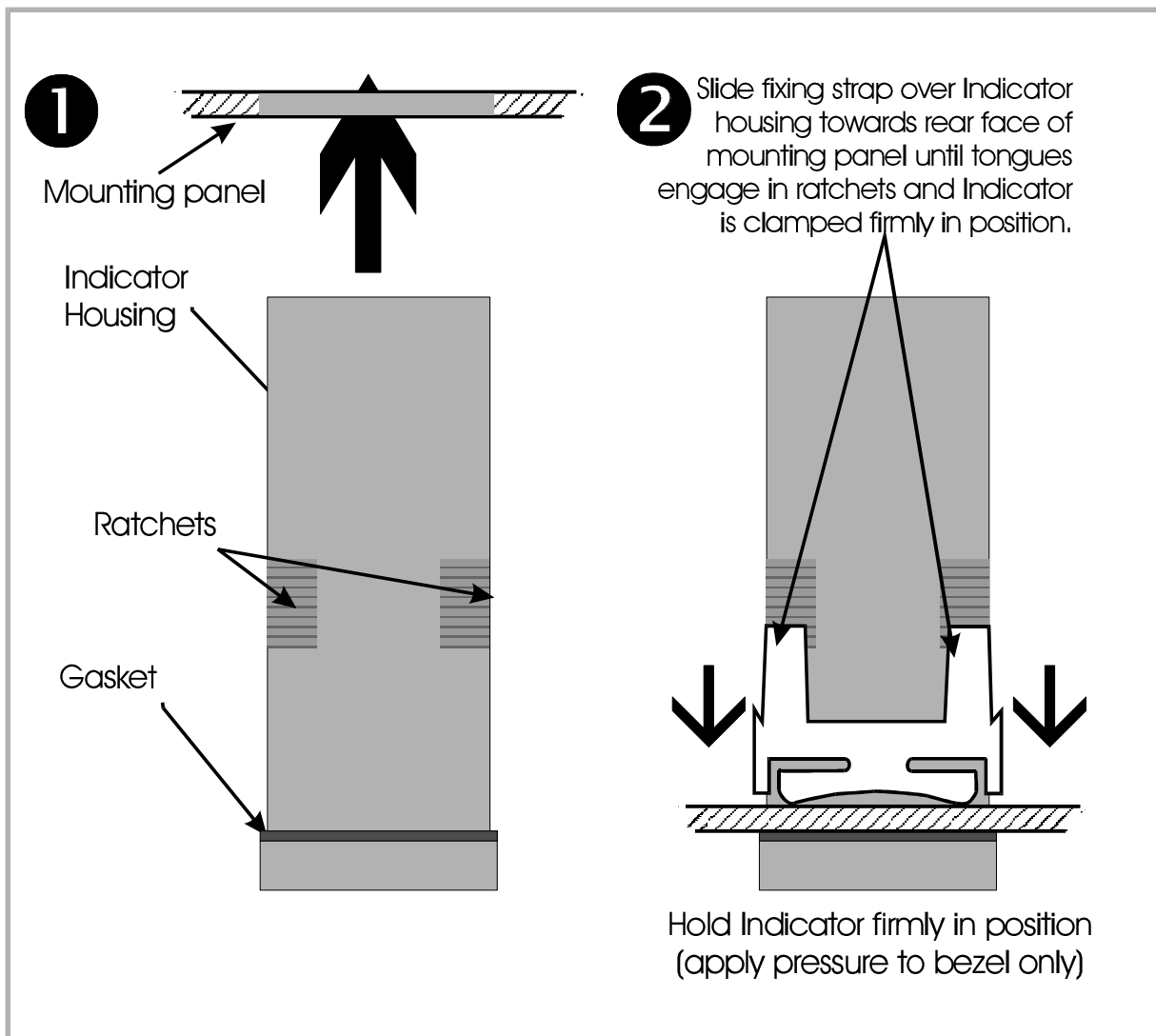

Figure 1-3 Panel-Mounting Procedure

### 1.3 CONNECTIONS AND WIRING

The rear terminal connections are illustrated in Figure 1-4.

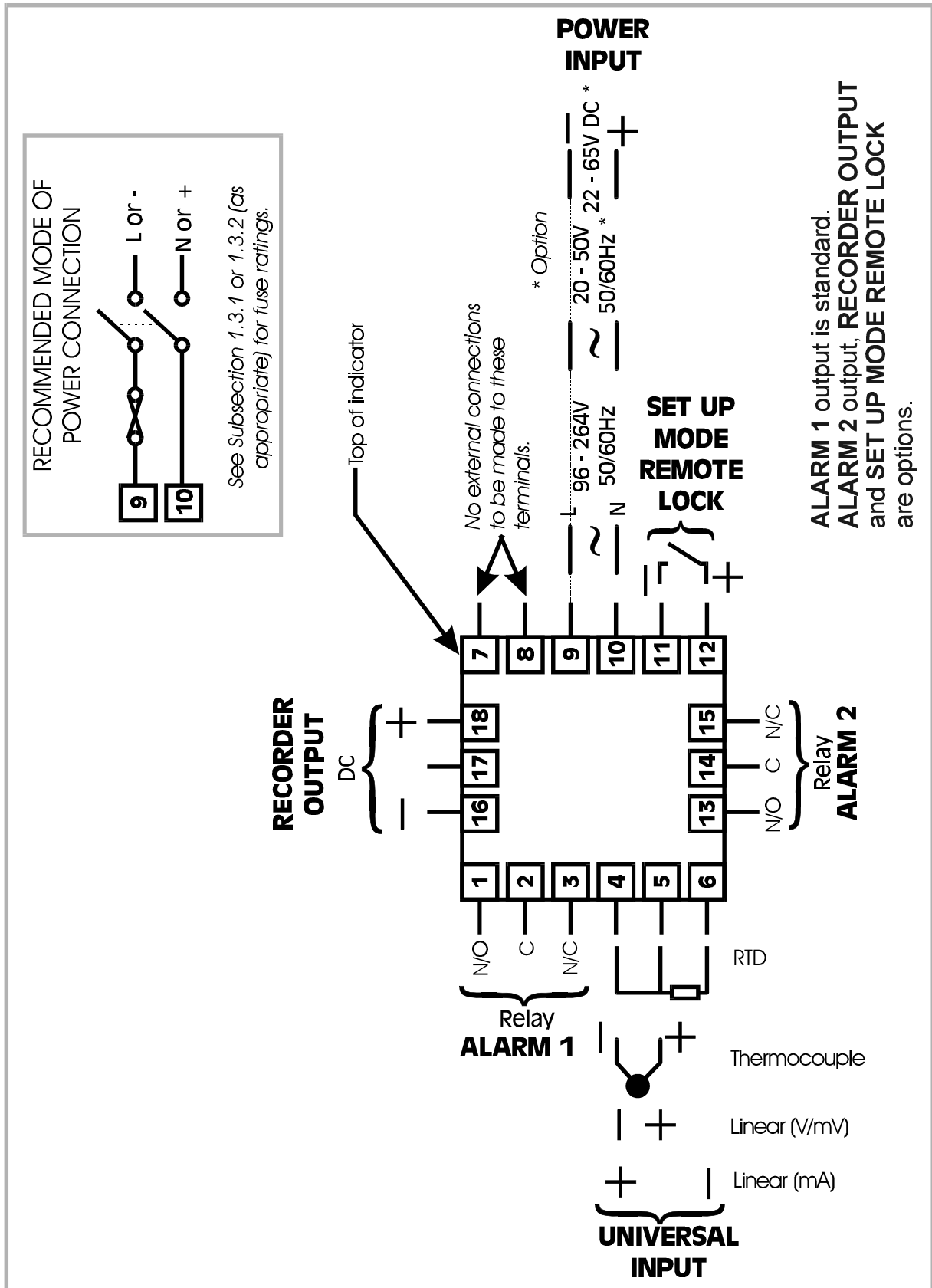

Figure 1-4 Rear Terminal Connections

### 1.3.1 Mains (Line) Input

The instrument will operate on 96 - 264V AC 50/60Hz mains (line) supply. The power consumption is approximately 4 VA.



**CAUTION:** This equipment is designed for installation in an enclosure which provides adequate protection against electric shock. Local regulations regarding electrical installation should be rigidly observed. Consideration should be given to prevention of access to the power terminations by unauthorised personnel. Power should be connected via a two-pole isolating switch (preferably situated near the equipment) and a 1A fuse, as shown in Figure 1-4.

If the instrument has relay outputs in which the contacts are to carry mains (line) voltage, it is recommended that the relay contact mains (line) supply should be switched and fused in a similar manner but should be separate from the instrument mains (line) supply.

### 1.3.2 24V (Nominal) AC/DC Supply

The supply connections for the 24V AC/DC version are shown in Figure 1-4. Power should be connected via a two-pole isolating switch and a 315mA slow-blow fuse (anti-surge Type T).

The nominal 24V supply may be in the following ranges:

24V (nominal) AC 50/60Hz -	20 - 50V
24V (nominal) DC -	22 - 65V

### 1.3.3 Thermocouple Input

The correct type of thermocouple extension leadwire/compensating cable must be used for the entire distance between the instrument and the thermocouple, ensuring that correct polarity is observed throughout. Joints in the cable should be avoided, if possible.

**NOTE:** Do not run thermocouple cables adjacent to power-carrying conductors. If the wiring is run in a conduit, use a separate conduit for the thermocouple wiring. If the thermocouple is grounded, this must be done at one point only. If the thermocouple extension lead is shielded, the shield must be grounded at one point only.

### 1.3.4 RTD Input

The compensating lead should be connected to Terminal 4. For two-wire RTD inputs, Terminals 4 and 5 should be linked. The extension leads should be of copper and the resistance of the wires connecting the resistance element should not exceed 5 ohms per lead (the leads should be of equal length).

### 1.3.5 Linear Input

For linear mA input ranges, connection is made to Terminals 4 and 6 in the polarity shown in Figure 1-4. For linear mV and V ranges, connection is made to Terminals 4 and 5 in the polarity shown in Figure 1-4. For details of the linear input ranges available, refer to Appendix A.

### 1.3.6 Set Up Mode Remote Lock (Option)

With this option fitted and configured, Terminals 11 and 12 may be connected to (a) the voltage-free contacts of a switch or relay, or (b) a TTL-compatible voltage. Set Up Mode entry/exit is initiated as follows:

Voltage-Free:       Contacts open - out of Set Up Mode  
                          Contacts closed - in Set Up Mode

TTL-compatible:     >2.0V - out of Set Up Mode  
                          <0.8V - in Set Up Mode

NOTE: When this option is fitted and configured, it is not possible to exit/enter Set Up Mode from the front panel. Also, the no key activity timeout for automatic exit from Set Up Mode is not operative.

### 1.3.7 Relay Outputs

The contacts are rated at 2A resistive at 120/240V AC.

### 1.3.8 DC Output (Recorder Output)

See Appendix A.

# 2 INTERNAL LINKS AND SWITCHES

## 2.1 REMOVING THE INSTRUMENT FROM ITS HOUSING

 **CAUTION:** Before removing the instrument from its housing, ensure that all power has been removed from the rear terminals.

To withdraw the instrument from its housing, simply grip the side edges of the front panel (there is a finger grip on each edge) and pull the instrument forwards. This will release the instrument from its rear connectors in the housing and will give access to the PCBs. Take note of the orientation of the instrument for subsequent replacement into the housing. The positions of the PCBs in the instrument are shown in Figure 2-1.

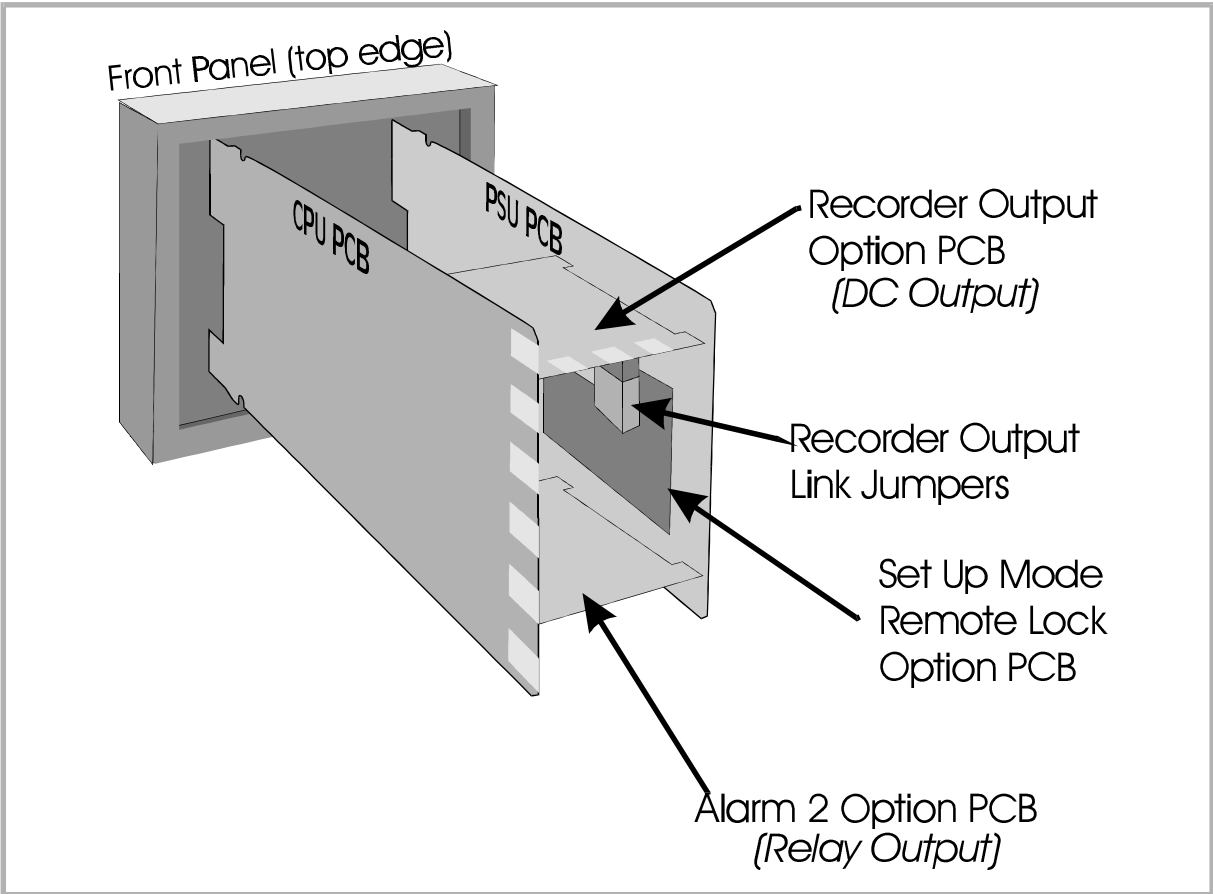

Figure 2-1 PCB Positions

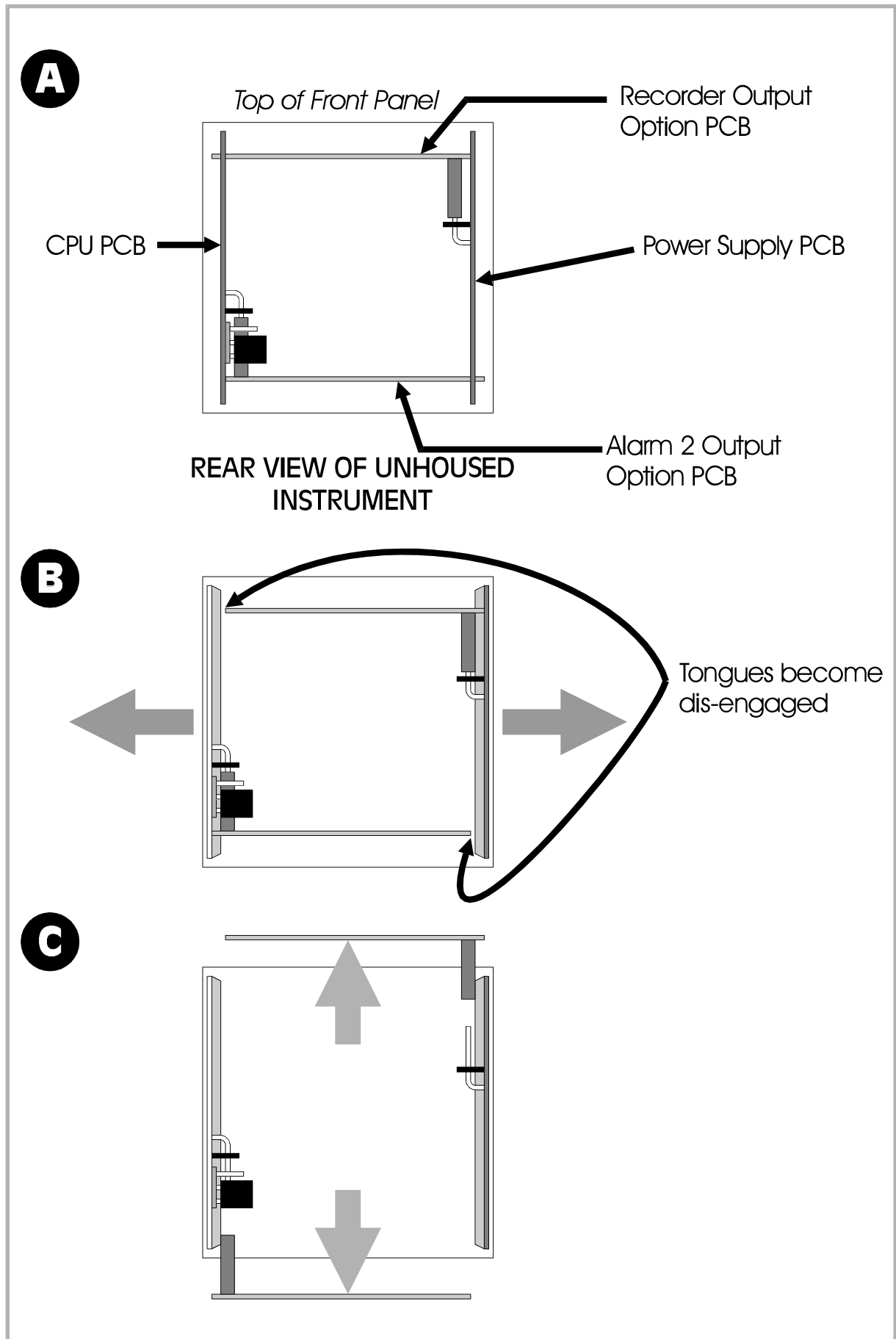

Figure 2-2 Removing the Alarm 2 Output/Recorder Output Option PCB

## 2.2 REMOVING/REPLACING THE ALARM 2/RECORDER OUTPUT OPTION PCBs

With the instrument removed from its housing:

1. Gently push the rear ends of the CPU PCB and Power Supply PCB apart slightly, until the two tongues on each of the Option PCBs become dis-engaged - see Figure 2-2B; The Alarm 2 Option PCB tongues engage in holes in the Power Supply PCB and the Recorder Output Option PCB tongues engage in holes on the CPU PCB.
2. Carefully pull the required Option PCB (Alarm 2 or Recorder Output) from its connector (Alarm 2 Option PCB is connected to the CPU PCB and Recorder Output Option PCB is connected to the Power Supply PCB) - see Figure 2-2C. Note the orientation of the PCB in preparation for its replacement.

Adjustments may now be made to the link jumpers on the CPU PCB. The replacement procedure is a simple reversal of the removal procedure.

## 2.3 REMOVING/REPLACING THE SET UP MODE REMOTE LOCK OPTION PCB

The Set Up Mode Remote Lock Option PCB is mounted on the inner surface of the Power Supply PCB and can be removed when the instrument is removed from its housing (see Subsection 2.1). Figure 2-3 illustrates the removal/replacement procedure. *It is not necessary to remove the Alarm 2/Recorder Output Option PCBs to perform this procedure.*

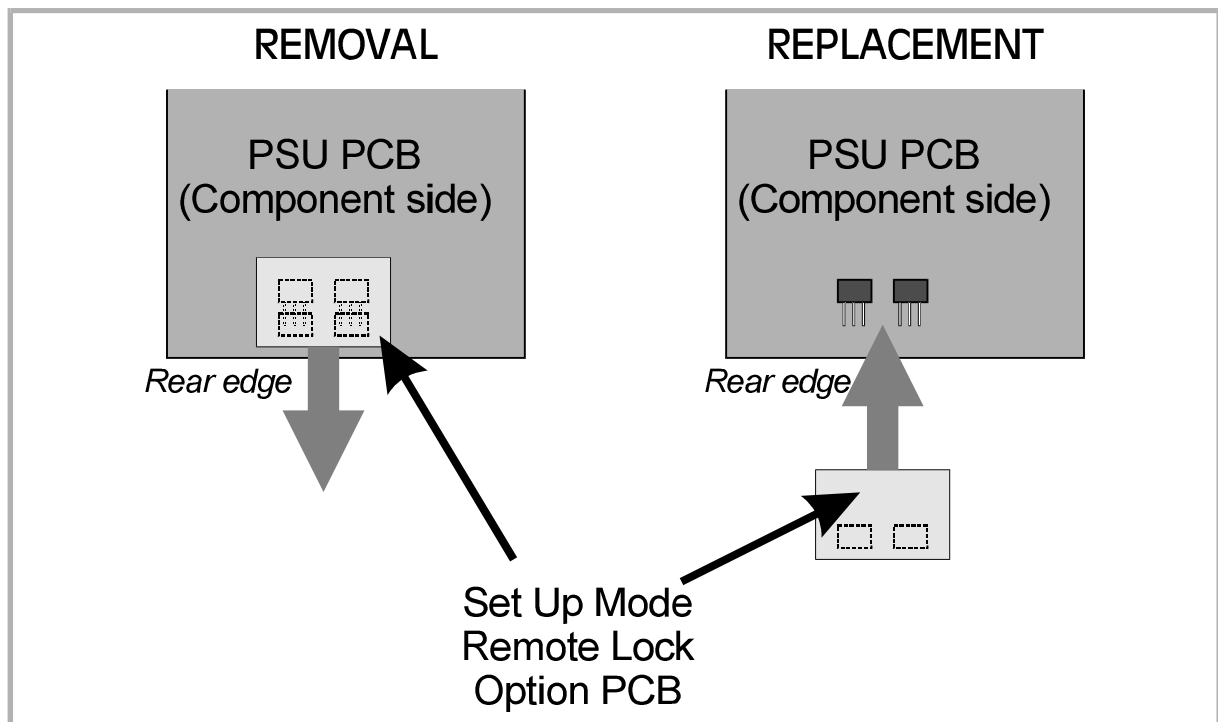

Figure 2-3 Removing/Replacing the Set Up Mode Remote Lock Option PCB

## 2.4 REPLACING THE INSTRUMENT IN ITS HOUSING

To replace the instrument, simply align the CPU PCB and Power Supply PCB with their guides and connectors in the housing and slowly but firmly push the instrument into position.

**CAUTION:** Ensure that the instrument is correctly orientated. A stop will operate if an attempt is made to insert the instrument in the wrong orientation (e.g. upside-down). *This stop must not be over-ridden.*

## 2.5 SELECTION OF INPUT TYPE

The required input type is selected on link jumpers LJ1/LJ2/LJ3 on the CPU PCB (see Figure 2-4 and Table 2-1).

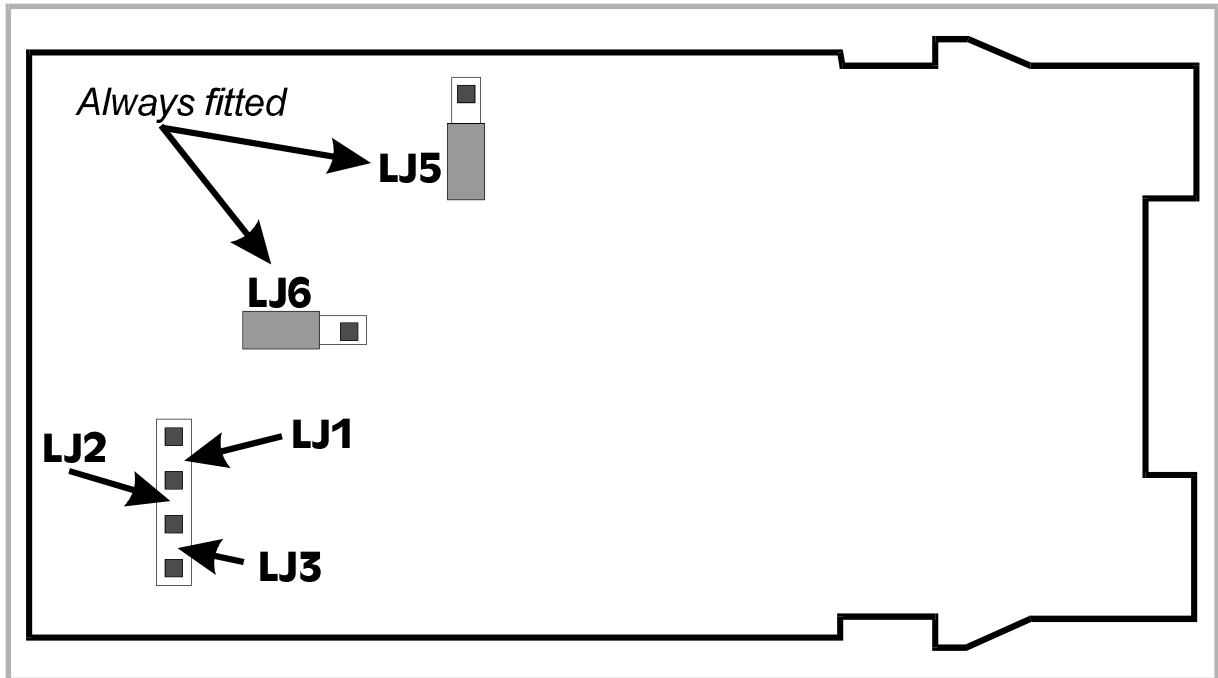

Figure 2-4 CPU PCB Link Jumpers

Table 2-1 Input Type Selection

Input Type	CPU PCB Link Jumper Fitted
RTD or DC (mV)	None (parked)
Thermocouple	LJ3
DC (mA)	LJ2
DC (V)	LJ1

## 2.6 ALARM 2 OUTPUT TYPE

Alarm 2 Output is always a relay type.

## 2.7 RECORDER OUTPUT RANGE SELECTION

The Recorder Output is a DC output, the range of which is determined by the setting of Link Jumpers LJ8 and LJ9 on the Recorder Output Option PCB (see Figure 2-5 and Table 2-2).

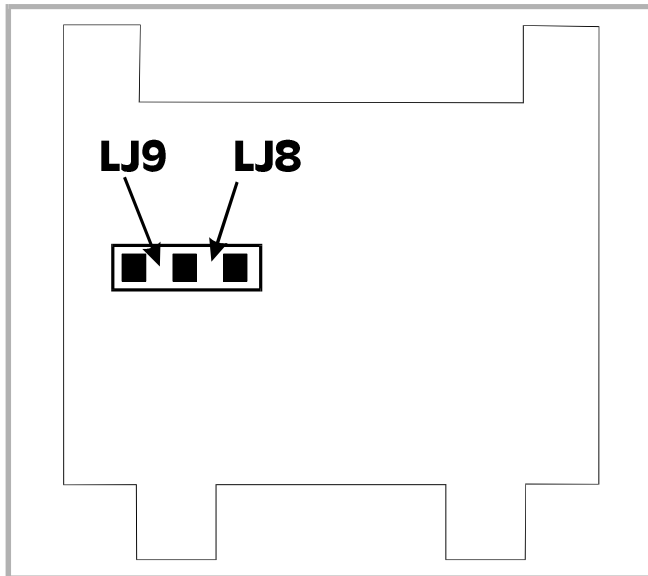

Figure 2-5 Recorder Output Option PCB

Table 2-2 Recorder Output Range Selection

Output Range	Link Jumper Fitted
0 - 10V	LJ8
0 - 20mA	LJ9
0 - 5V	LJ8
4 - 20mA	LJ9

# 3 CONFIGURATION MODE

## 3.1 ENTRY INTO CONFIGURATION MODE

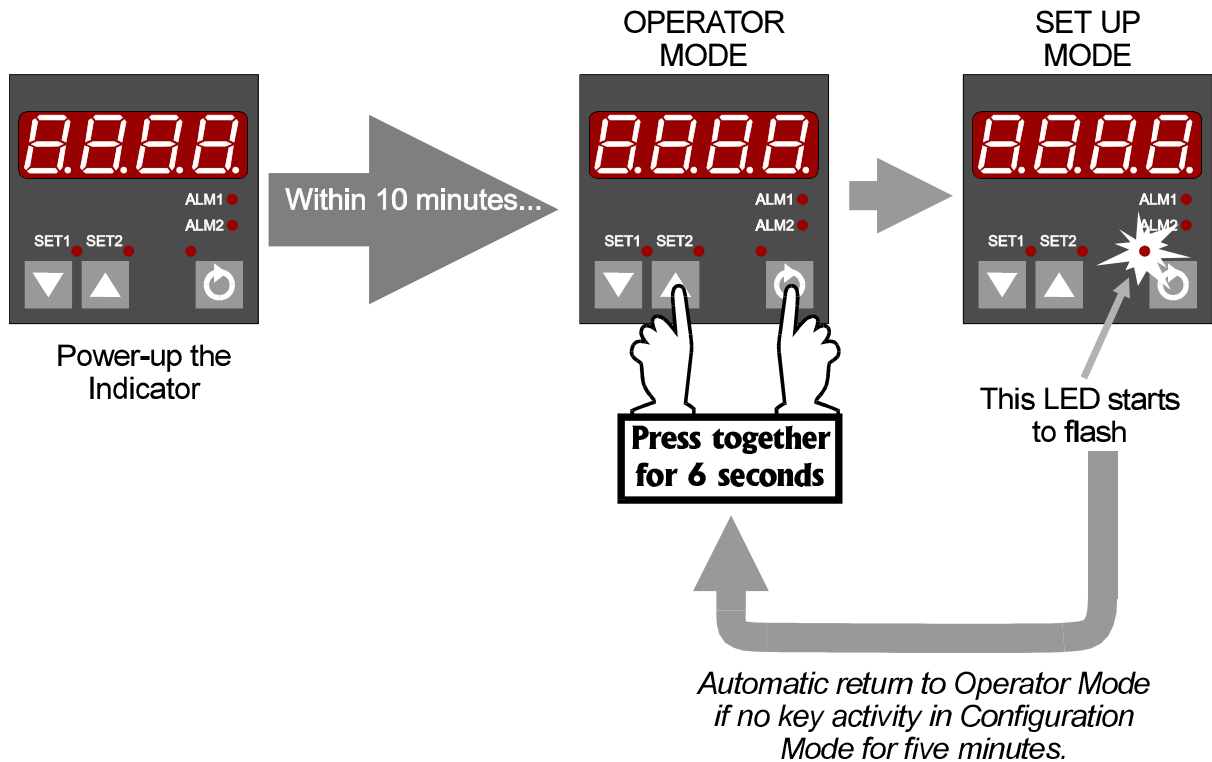

If this is done whilst the instrument is displaying the process variable value, the instrument will enter/exit Set Up Mode - *keep holding the keys down!*

NOTE: This need not be the first key action after power-up.

The user is then presented with the first of a sequence of parameter displays; in each instance, the parameter is identified by the state of the **SET1** and **SET2** indicators and the setting of that parameter is shown in the four-digit display. The user may then step through the parameters using the Scroll key. The setting may be adjusted using the Raise/Lower keys. As soon as the value/setting is changed, the four-digit display will flash, indicating that the new value/setting has yet to be confirmed (this flashing is inhibited during actual adjustment). When the value/setting is as required, it may be confirmed by:

(a) pressing the Scroll key, whereupon the four-digit display will show:



(b) pressing the Raise key.







# APPENDIX A PRODUCT SPECIFICATION

## UNIVERSAL INPUT

### General

Maximum per Instrument:	One
Input Sample Rate:	Four samples/second
Digital Input Filter:	Time constant selectable from front panel - 0.0 (i.e. OFF), 0.5 to 100.0 seconds in 0.5-second increments.
Input Resolution:	14 bits approximately; always four times better than display resolution.
Input Impedance:	Greater than 100M $\Omega$ resistive (except for DC mA and V inputs).
Isolation:	Universal input isolated from all outputs except SSR Drive at 240V AC.

### Thermocouple

Ranges selectable from front panel:

Type	Input Range	Displayed Code	Type	Input Range	Displayed Code
R	0 - 1650°C	1127	J	32 - 1401°F	1420
R	32 - 3002°F	1128	T	-200 - 262°C	1525
S	0 - 1649°C	1227	T	-328 - 503°F	1526
S	32 - 3000°F	1228	T	0.0 - 260.6°C	1541
J	0.0 - 205.4°C	1415	T	32.0 - 501.0°F	1542
J	32.0 - 401.7°F	1416	K	-200 - 760°C	6726
J	0 - 450°C	1417	K	-328 - 1399°F	6727
J	32 - 842°F	1418	K	-200 - 1373°C	6709
J	0 - 761°C *	1419	K	-328 - 2503°F	6710

\* Default setting

Continued overleaf⇒

Type	Input Range	Displayed Code	Type	Input Range	Displayed Code
L	0.0 - 205.7°C	1815	L	32 - 1403°F	1820
L	32.0 - 402.2°F	1816	B	211 - 3315°F	1934
L	0 - 450°C	1817	B	100 - 1824°C	1938
L	32 - 841°F	1818	N	0 - 1399°C	5371
L	0 - 762°C	1819	N	32 - 2550°F	5324

Calibration: Complies with BS4937, NBS125 and IEC584.

Sensor Break Protection: Break detected within two seconds. Alarms operate as if the process variable has gone over-range.

### Resistance Temperature Detector (RTD) and DC mV

Ranges selectable from front panel:

Input Range	Displayed Code	Input Range	Displayed Code
0 - 800°C *	7220	0.0 - 100.9°C	2295
32 - 1471°F	7221	32.0 - 213.6°F	2296
32 - 571°F	2229	-200 - 206°C	2297
-100.9 - 100.0°C	2230	-328 - 402°F	2298
-149.7 - 211.9°F	2231	-100.9 - 537.3°C	7222
0 - 300°C	2251	-149.7 - 999.1°F	7223

\* Default setting

Type and Connection: Three-wire Pt100

Calibration: Complies with BS1904 and DIN43760.

Lead Compensation: Automatic scheme.

RTD Sensor Current: 150 $\mu$ A (approximately)

Sensor Break Protection: Break detected within two seconds. For RTD input, alarms operate as if the process variable has gone under-range. For DC (mV) input, alarms operate as if the process variable has gone over-range.



**OUTPUT 1 (Relay)**

Contact Type:	Single pole double throw (SPDT).
Rating:	2A resistive at 120/240V AC.
Lifetime:	>500,000 operations at rated voltage/current.
Isolation:	Inherent.

**ALARM 2 OUTPUT (Relay) - option**

Contact Type:	Single pole double throw (SPDT).
Rating:	2A resistive at 120/240V AC.
Lifetime:	>500,000 operations at rated voltage/current.
Isolation:	Inherent.

**RECORDER OUTPUT (DC LINEAR) - option**

Resolution:	Eight bits in 250mS (10 bits in 1 second typical, >10 bits in >1 second typical).
Update Rate:	Every control algorithm execution.
Ranges:	0 - 20mA, 4 - 20mA, 0 - 10V and 0 - 5V

(Changes between V and mA require link jumper movement.)

Load Impedance:	0 - 20mA: 500 $\Omega$ maximum 4 - 20mA: 500 $\Omega$ maximum 0 - 10V: 500 $\Omega$ minimum 0 - 5V: 500 $\Omega$ minimum
Isolation:	Isolated from all other inputs and outputs.
Range Selection Method:	Link jumper or DIP.

**ALARM CONTROL**

Maximum Number of Alarms:	Two soft alarms
Max. No. of Outputs Available:	Up to two outputs can be utilised for alarm purposes.

## PERFORMANCE

### Reference Conditions

Generally as EN60546-1.

Ambient Temperature:	20°C ±2°C
Relative Humidity:	60 - 70%
Supply Voltage:	90 - 264V AC 50Hz ±1%
Source Resistance:	<10Ω for thermocouple input
Lead Resistance:	<0.1Ω/lead balanced (Pt100)

### Performance Under Reference Conditions

Common Mode Rejection:	>120dB at 50/60Hz giving negligible effect at up to 264V 50/60Hz.
Series Mode Rejection:	>500% of span (at 50/60Hz) causes negligible effect.

### DC Linear Inputs

Measurement Accuracy:	±0.25% of span ±1LSD.
-----------------------	-----------------------

### Thermocouple Inputs

Measurement Accuracy:	±0.25% of span ±1LSD. NOTE: Reduced performance with Type B Thermocouple between 100 - 600°C (212 - 1112°F).
Linearisation Accuracy:	Better than ±0.2°C any point, any 0.1°C range (±0.05°C typical). Better than ±0.5°C any point, any 1°C range.
Cold Junction Compensation:	Better than ±0.7°C.

### RTD Inputs

Measurement Accuracy:	±0.25% of span ±1LSD
Linearisation Accuracy:	Better than ±0.2°C any point, any 0.1°C range (±0.05°C typical). Better than ±0.5°C any point, any 1°C range.

## Recorder Output

Accuracy:  $\pm 0.25\%$  (mA @  $250\Omega$ , V @  $2k\Omega$ ); Degrades linearly to  $\pm 0.5\%$  for increasing burden (to specification limits).

## Operating Conditions

Ambient Temperature (Operating):  $0^{\circ}\text{C}$  to  $55^{\circ}\text{C}$

Ambient Temperature (Storage):  $20^{\circ}\text{C}$  to  $80^{\circ}\text{C}$

Relative Humidity: 20% - 95% non-condensing

Supply Voltage: 90 - 264V AC 50/60Hz (standard)  
20 - 50V AC 50/60Hz or 22 - 65V DC (option)

Source Resistance:  $1000\Omega$  maximum (thermocouple)

Lead Resistance:  $50\Omega$  per lead maximum balanced (Pt100)

## Performance Under Operating Conditions

Temperature Stability: 0.01% of span/ $^{\circ}\text{C}$  change in ambient temperature.

Cold Junction Compensation (thermocouple only): Better than  $\pm 1^{\circ}\text{C}$ .

Supply Voltage Influence: Negligible.

Relative Humidity Influence: Negligible

Sensor Resistance Influence: Thermocouple  $100\Omega$ :  $<0.1\%$  of span error  
Thermocouple  $1000\Omega$ :  $<0.5\%$  of span error  
RTD Pt100  $50\Omega/\text{lead}$ :  $<0.5\%$  of span error

**ENVIRONMENTAL**

Operating Conditions:	See PERFORMANCE.
Approvals:	CE, UL, ULC
EMI Susceptibility:	Certified to EN50082-1:1992 and EN50082-2:1995. NOTE: For line-conducted disturbances induced by RF fields (10V 80% AM 1kHz), the product is self-recoverable in the frequency bands 17 - 47MHz and 68 - 80MHz.
EMI Emissions:	Certified to EN50081-1:1992 and EN50081-2:1994.
Safety Considerations:	Complies with EN61010-1:1993.
Supply Voltage:	90 - 264V AC 50/60Hz (standard) 20 - 50V AC 50/60Hz or 22 - 65V DC (option)
Power Consumption:	4 watts approximately.
Front Panel Sealing:	To IP66 (NEMA 4).

**PHYSICAL**

Dimensions:	Depth - 110mm  Front Panel:  Width - 48mm, Height - 48mm (1/16 DIN)
Mounting:	Plug-in with panel mounting fixing strap. Panel cut-out 45mm x 45mm.
Terminals:	Screw type (combination head).
Weight:	0.21kg maximum