

1/8-DIN

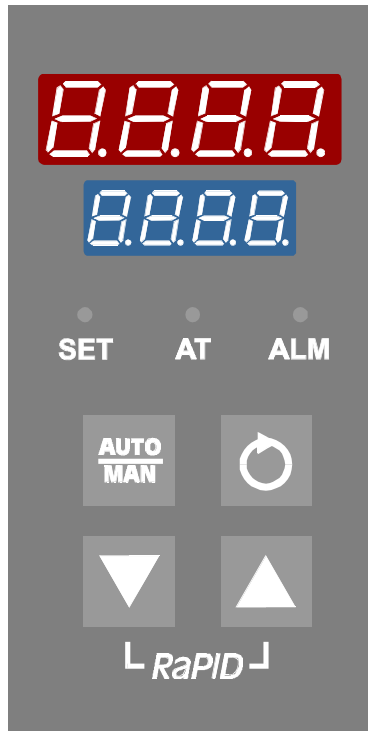

1/4-DIN



$\frac{1}{4}$ -DIN & $\frac{1}{8}$ -DIN RaPID TEMPERATURE CONTROLLERS

Product Manual

59131-2
(June 1999)

How to use this manual

VOLUME I OPERATING INSTRUCTIONS

SECTION 1	Adjusting the setpoint and setpoint ramp rate Alarm status display Pre-Tune, Self-Tune and RaPID control Manual Control
SECTION 2	Setting up the Controller parameters Manually tuning the Controller
SECTION 3	Setting up and using the communications link between the Controller and your computer

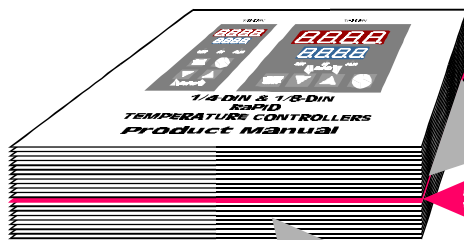

To find a specific topic, refer to the index at the rear of this manual

VOLUME II INSTALLATION & CONFIGURATION INSTRUCTIONS

SECTION 1	Panel-mounting and wiring-up the Controller
SECTION 2	Selecting the required input/output type(s)
SECTION 3	Matching software to hardware fitted Selecting input range, control action, and alarm type(s)
APPENDIX A	Product specification
APPENDIX B	Description of RaPID control feature
APPENDIX C	Description of Alarm Hysteresis Output



The functions described in Volume II must be performed only by personnel who are trained, equipped and authorised to do so.

$\frac{1}{4}$ -DIN & $\frac{1}{8}$ -DIN RaPID TEMPERATURE CONTROLLERS

PRODUCT MANUAL

VOLUME I OPERATING INSTRUCTIONS

In normal operation, the operator must not remove the Controller from its housing or have unrestricted access to the rear terminals, as this would provide potential contact with hazardous live parts.

Installation and configuration must be undertaken by technically-competent servicing personnel. This is covered in Volume II of this manual.

Contents

1	OPERATOR MODE	1-1
1.1	DISPLAYS AVAILABLE	1-1
1.2	OVERRIDE FEATURE	1-4
1.3	VIEWING/ADJUSTING THE SETPOINT VALUE	1-4
1.4	VIEWING/ADJUSTING THE SETPOINT RAMP RATE	1-4
1.5	ALARM STATUS DISPLAY	1-5
1.6	OVER-RANGE/UNDER-RANGE DISPLAYS	1-5
1.7	SENSOR BREAK INDICATION	1-5
1.8	MANUAL CONTROL MODE	1-6
1.9	PRE-TUNE FACILITY	1-6
1.10	SELF-TUNE FACILITY	1-7
1.11	THE RaPID FEATURE	1-8
1.12	VIEWING THE HARDWARE DEFINITION CODE	1-8

2	SET UP MODE	2-1
2.1	ENTRY INTO SET UP MODE	2-1
2.2	SET UP MODE PARAMETERS	2-2
2.3	OPERATOR MODE DISPLAYS	2-14
2.4	TUNING THE CONTROLLER MANUALLY	2-15
2.5	EXIT FROM SET UP MODE	2-16
3	RS485 SERIAL COMMUNICATIONS	3-1
3.1	COMMUNICATIONS ENABLE/DISABLE	3-1
3.2	PHYSICAL REQUIREMENTS	3-1
3.3	INDIVIDUAL PARAMETERS	3-5
3.4	ERROR RESPONSE	3-13

1 OPERATOR MODE

1.1 DISPLAYS AVAILABLE

The displays available are dependent upon (a) whether the Controller is configured for single setpoint, dual setpoint or local/remote setpoint operation, and (b) the setpoint strategy selected (see Subsection 2.2.40).

Single Setpoint Operation

Default

Setpoint Strategy = 1	Process Variable Setpoint	Setpoint SP	Ramping Setpoint SP-rP	Setpoint Ramp Rate rP
Setpoint Strategy = 2	Process Variable Setpoint	Ramping Setpoint SP-rP	Setpoint Ramp Rate rP	
Setpoint Strategy = 3	Process Variable (Ramping) Setpoint	Setpoint SP	Ramping Setpoint SP-rP	Setpoint Ramp Rate rP
Setpoint Strategy = 4	Process Variable	Setpoint SP	Ramping Setpoint SP-rP	Setpoint Ramp Rate rP
Setpoint Strategy = 5	Setpoint	Setpoint SP	Ramping Setpoint SP-rP	Setpoint Ramp Rate rP



To select display



To adjust displayed value (if it is adjustable)

Ramping Setpoint and Setpoint Ramp Rate displays appear only if setpoint ramping is not disabled and ramp rate is not switched OFF.

Adjustable

Non-adjustable

Dual Setpoint Operation

Default

Setpoint Strategy = 1	Process Variable Active Setpoint	Setpoint 1 SP1	Setpoint 2 SP2	Ramping Setpoint SP-P	Setpoint Ramp Rate r-P
Setpoint Strategy = 2	Process Variable Active Setpoint	Setpoint 1 SP1	Setpoint 2 SP2	Ramping Setpoint SP-P	Setpoint Ramp Rate r-P
Setpoint Strategy = 3	Process Variable Ramping or Active SP	Setpoint 1 SP1	Setpoint 2 SP2	Ramping Setpoint SP-P	Setpoint Ramp Rate r-P
Setpoint Strategy = 4	Process Variable	Setpoint 1 SP1	Setpoint 2 SP2	Ramping Setpoint SP-P	Setpoint Ramp Rate r-P
Setpoint Strategy = 5	Active Setpoint	Setpoint 1 SP1	Setpoint 2 SP2	Ramping Setpoint SP-P	Setpoint Ramp Rate r-P

 To select display

 To adjust displayed value (if it is adjustable)

Ramping Setpoint and Setpoint Ramp Rate displays appear only if setpoint ramping is not disabled and ramp rate is not switched OFF.

Adjustable Non-adjustable

NOTE: The left-most character of the lower display distinguishes between the active and inactive setpoints in the following manner:



Active Setpoint
(selected via digital input)



Active Setpoint
(selected via front panel key override - see Subsection 2.3)



Inactive Setpoint

Remote Setpoint Operation

Default

Setpoint Strategy = 1	Process Variable Active Setpoint	Local Setpoint LSP	Remote Setpoint rSP	Ramping Setpoint SPrP	Setpoint Ramp Rate rP
Setpoint Strategy = 2	Process Variable Active Setpoint	Local Setpoint LSP	Remote Setpoint rSP	Ramping Setpoint SPrP	Setpoint Ramp Rate rP
Setpoint Strategy = 3	Process Variable Ramping/active Setpoint	Local Setpoint LSP	Remote Setpoint rSP	Ramping Setpoint SPrP	Setpoint Ramp Rate rP
Setpoint Strategy = 4	Process Variable	Local Setpoint LSP	Remote Setpoint rSP	Ramping Setpoint SPrP	Setpoint Ramp Rate rP
Setpoint Strategy = 5	Active Setpoint	Local Setpoint LSP	Remote Setpoint rSP	Ramping Setpoint SPrP	Setpoint Ramp Rate rP



To select display

Ramping Setpoint and Setpoint Ramp Rate displays appear only if setpoint ramping is not disabled and ramp rate is not switched OFF.



To adjust displayed value (if it is adjustable)

Adjustable

Non-adjustable

NOTE: The left-most character of the lower display uses the left-most character to distinguish between the active and inactive setpoints in the following manner:



Active Setpoint
(selected via digital input)



Active Setpoint
(selected via front panel key override - see Subsection 2.3)



Inactive Setpoint

1.2 OVERRIDE FEATURE

In either Dual Setpoint operation or Remote Setpoint operation, the Override feature is available. This enables the active setpoint selected by the digital input to be manually overridden from the keyboard. To engage the Override feature, with the Controller displaying the desired setpoint value (see Subsection 1.1):

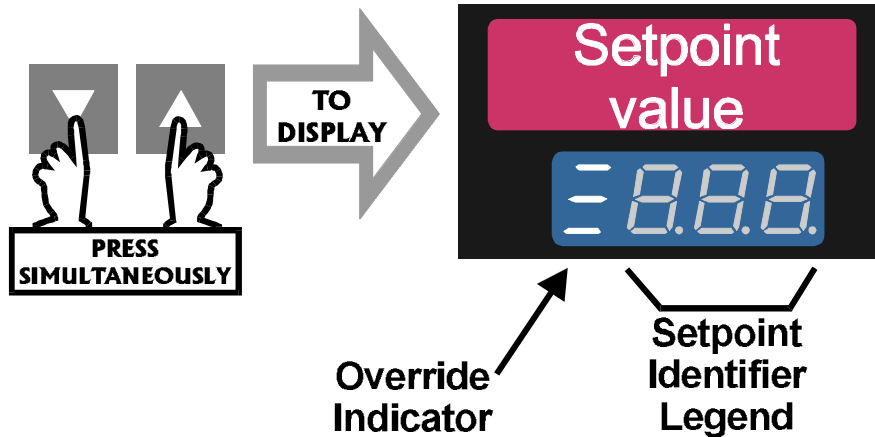

This indicates that the displayed setpoint is now the active setpoint, *regardless of the state of the digital input*. To cancel an Override condition, press the same keys again with this display shown.

1.3 VIEWING/ADJUSTING THE SETPOINT VALUE

If the desired setpoint display (i.e. lower display showing the legend SP, SP1, SP2 or LSP as appropriate) is selected (see Subsection 1.1), the setpoint value can be adjusted using the Raise/Lower keys.



1.4 VIEWING/ADJUSTING THE SETPOINT RAMP RATE

If setpoint ramping is enabled, the ramp rate display may be selected (see Subsection 1.1). The ramp rate (expressed in units/hour) may be adjusted (using the Raise/Lower keys) within the range 1 to 9999. Any attempt to increase the value beyond 9999 will cause the upper display to go blank and setpoint ramping to be switched OFF (default).



1.5 ALARM STATUS DISPLAY

If any alarm is active, the Alarm Status can be displayed as follows:

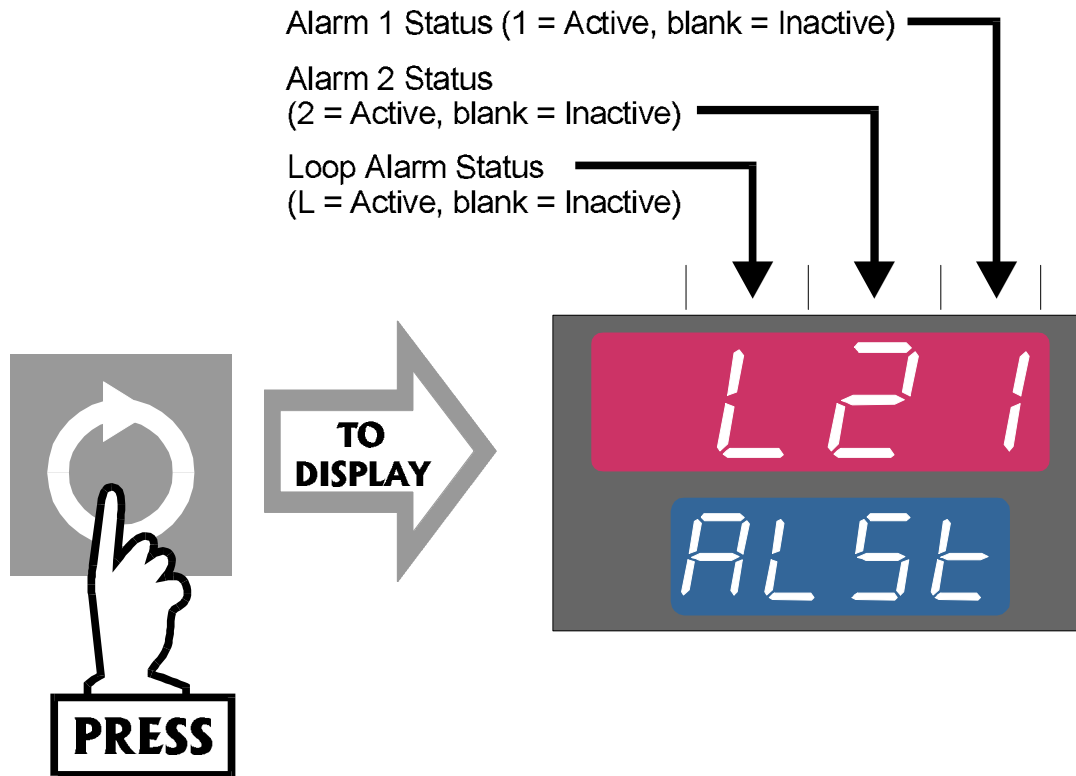

NOTE: If no alarm is active, *this display is not available.*

1.6 OVER-RANGE/UNDER-RANGE DISPLAYS

If the process variable attains a value outside the input scale, the upper display will show the appropriate one of the following:



Input over-range



Input under-range

1.7 SENSOR BREAK INDICATION

If a break is detected in the sensor circuit, the upper display will show:



The reaction of the outputs and alarms to a detected sensor break is dependent upon the input type.

1.8 MANUAL CONTROL MODE

If selection of Manual Control Mode is enabled (see Subsection 2.2.38) the Manual Control Mode may be entered by depressing the **AUTO/MAN** key. The **SET** indicator will then flash. The output power will be displayed and may be adjusted with the Raise/Lower keys. A return can be made to Automatic Control Mode by simply depressing the **AUTO/MAN** key again.



1.9 PRE-TUNE FACILITY

This facility may be used to set the Controller's PID parameters. Pre-Tune may be activated as follows:

To engage:

- 1 With Controller showing a normal Operator Mode display:

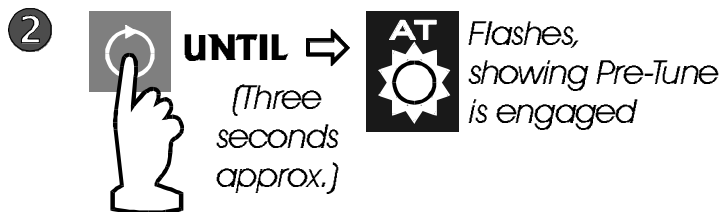
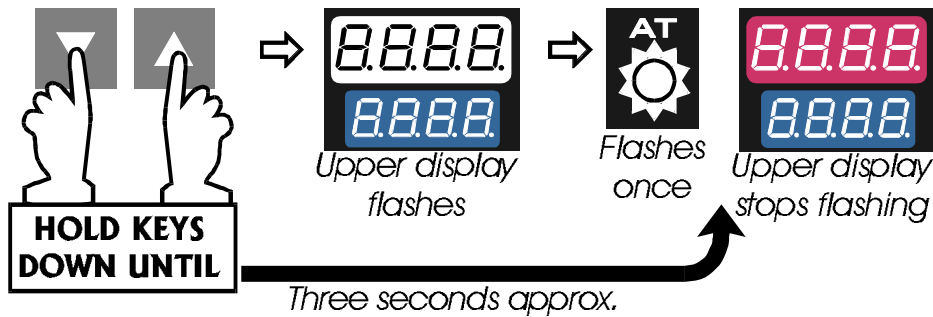

To dis-engage:

- 1 With Controller showing a normal Operator Mode display:

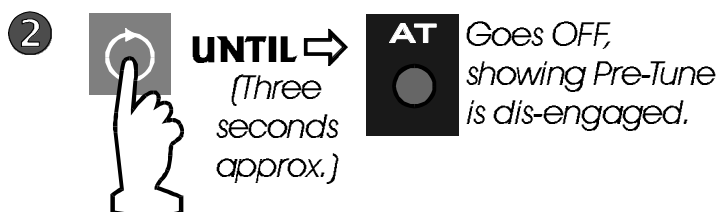
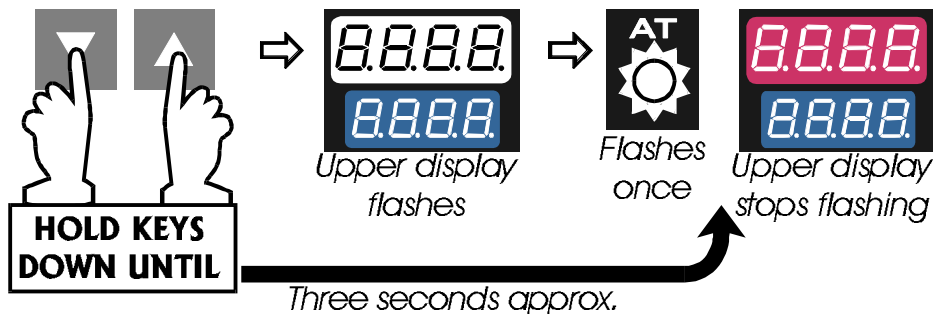

NOTES: The Pre-Tune facility will not engage if the setpoint is currently ramping or if the process variable is less than 5% of input span from the setpoint. Since the Pre-Tune facility is a single-shot operation, it will automatically dis-engage itself once the operation is complete. The Pre-Tune facility and the RaPID feature may be engaged together (see Subsection 1.11).

1.10 SELF-TUNE FACILITY

This facility is used to optimise tuning whilst the Controller is operating. Self-Tune may be activated as follows:

To engage:

- 1 With Controller showing a normal Operator Mode display:

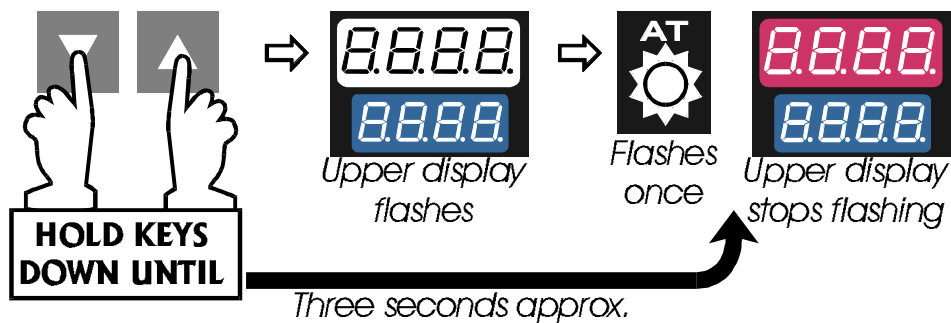

To dis-engage:

- 1 With Controller showing a normal Operator Mode display:

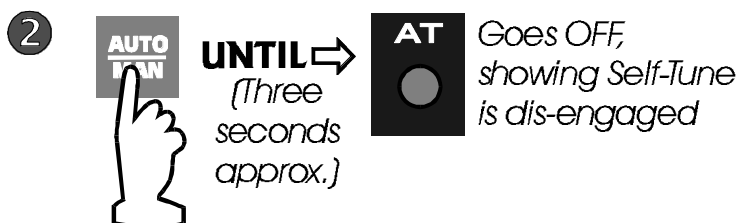
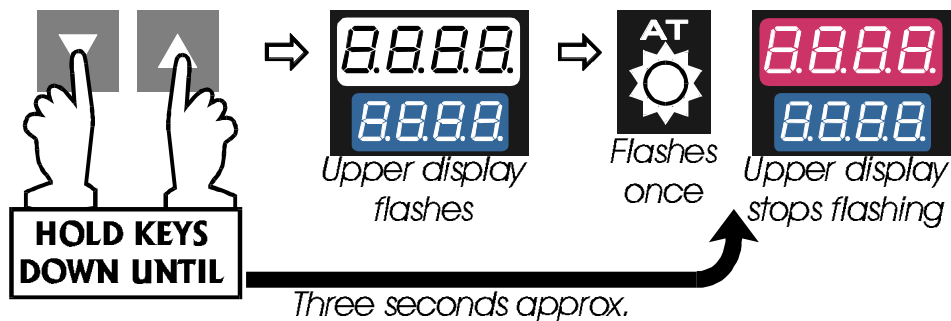

1.11 THE RaPID FEATURE

To engage the RaPID feature:

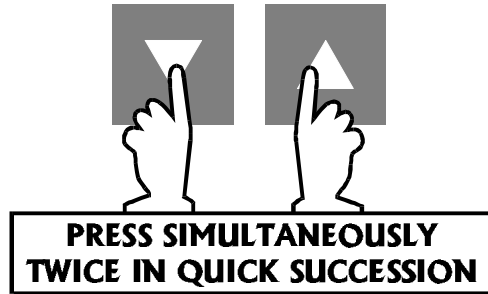

The same key action is used to dis-engage the RaPID feature.

To engage the RaPID feature and the Pre-Tune feature together:

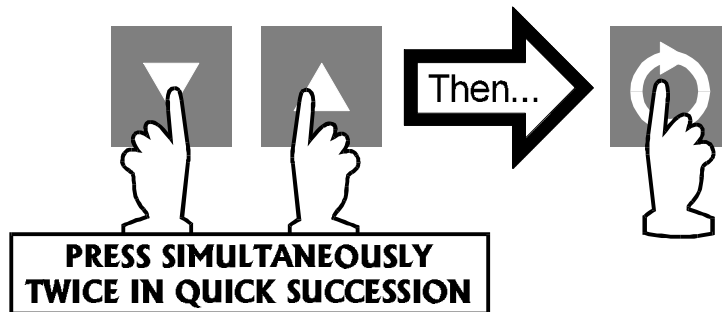

The Pre-Tune feature then performs its single-shot operation (AT indicator will flash green), after which the RaPID feature automatically starts to operate (AT indicator will be ON green). For a detailed description of the RaPID feature, refer to Appendix B.

NOTE: If either PB1 or PB2 is zero, the RaPID feature cannot be engaged.

1.12 VIEWING THE HARDWARE DEFINITION CODE

The Hardware Definition Code indicates the hardware (input type, output types) currently configured/fitted in the Controller. To view this code:

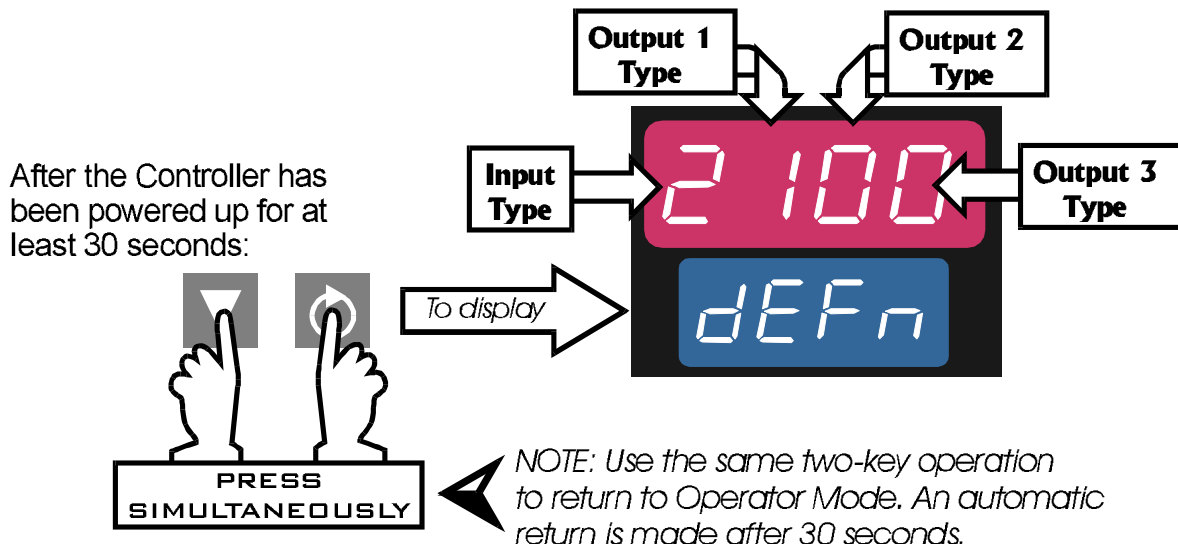

The Hardware Definition Code has the following significance:

Value	0	1	2	3	4	5	7
Input Type		RTD/ Linear DC (mV)	Thermo- couple	Linear DC (mA)	Linear DC (V)		
Output 1 Type		Relay	SSR Drive or Solid State	DC (0 - 10V)	DC (0 - 20mA)	DC (0 - 5V)	DC (4 - 20mA)
Output 2 Type	Not fitted	Relay	SSR Drive or Solid State	DC (0 - 10V)	DC (0 - 20mA)	DC (0 - 5V)	DC (4 - 20mA)
Output 3 Type	Not fitted	Relay	SSR Drive or Solid State	DC (0 - 10V)	DC (0 - 20mA)	DC (0 - 5V)	DC (4 - 20mA)

2 SET UP MODE

2.1 ENTRY INTO SET UP MODE

1 Put Controller in Operator Mode with normal display.

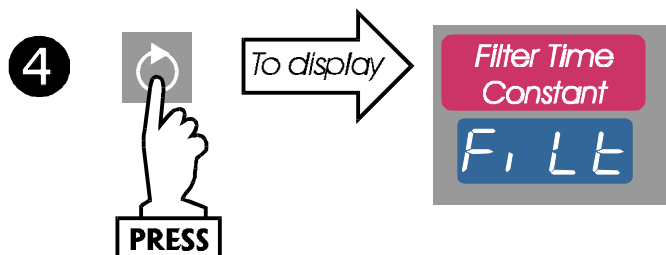
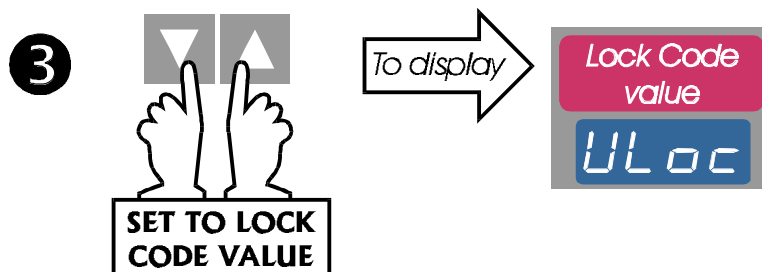
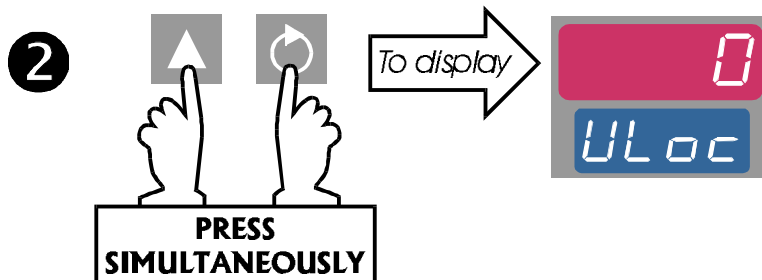

If the upper display does not show the correct Lock Code value when this key is pressed, a return is made to the original Operator Mode display.

NOTE: If the upper display shows:



one or more of the critical Configuration Mode parameters - typically input range or output use/type - have been altered and, as a consequence, all Set Up Mode parameters have been automatically set to their default values/settings. To clear this display, alter any Set Up Mode parameter (see below). It is recommended that Set Up Mode parameters are adjusted to requirements *only after all configuration parameters have been finalised*.

2.2 SET UP MODE PARAMETERS

The parameters available for view/adjustment in Set Up Mode are summarised in Table 2-1.

When Set Up Mode is entered, the lower display will show the legend for the first parameter (Filter Time Constant) and the filter time constant value will be shown in the upper display. The user may then select and adjust Set Up Mode parameters (see left). In each case, the legend identifying the parameter will be shown in the lower display and the current value/setting will be shown in the upper display.



To select parameter



To decrease value



To increase value

2.2.1 Input Filter Time Constant

The Controller input is equipped with a digital filter which is used to filter out any extraneous impulses on the process variable. This filtered PV is used for all PV-dependent functions (control, alarms etc.).

CAUTION: If this parameter is set to an excessively high value, the control quality may be significantly impaired. The value chosen should be sufficiently large to attenuate stray noise on the process variable signal but no larger.

2.2.2 Process Variable Offset

This parameter is used to modify the actual process variable value (measured at the Controller's input terminals) in the following manner:

Offset PV value = Actual PV value + Process Variable Offset value.

For Controllers fitted with a linear input, the displayed process variable value is limited by Scale Range Maximum (see Subsection 2.2.35) and Scale Range Minimum (see Subsection 2.2.36). The offset process variable value is used for all PV-dependent functions (control, display, alarm, recorder output etc.).

CAUTION: This parameter value should be chosen with care. Any adjustment to this parameter is, in effect, a calibration adjustment. Injudicious application of values to this parameter could lead to the displayed process variable value bearing no meaningful relationship to the actual process variable value. There is no front panel indication when this parameter is in effect (i.e. has been set to a non-zero value).

2.2.3 Output Power 1

This parameter is the current Output 1 power level.

Table 2-1 Set Up Mode Parameters

Parameter	Legend	Adjustment Range	Default Value
Digital Filter Time Constant	FILT	OFF, 0.5 to 100.0 secs. In 0.5 sec. increments	2.0 seconds
Process Variable Offset	OFFS	±Span of Controller	0
Output Power	OUT1	0 to 100%	Read only
Output Power 2 ⁵	OUT2	0 to 100%	Read only
Proportional Band 1 ¹²	PB1	0.0 (ON/OFF control) to 999.9% of input span	10.0%
Proportional Band 2 ^{1,5,12}	PB2	0.0 (ON/OFF control) to 999.9% of input span	10.0%
Reset (Integral Time Const.) ¹	RSET	1s to 99m 59s and OFF	5m 00s
Rate (Derivative Time Const.) ¹	RATE	00s to 99m 59s	1m 15s
Overlap/Deadband ^{1,5}	OL	-20% to +20% (of Proportional Band 1 + Proportional Band 2)	0%
Manual Reset (Bias) ¹	BIAS	0% to 100% (Output 1 only) -100% to +100% (Output 1 & Output 2)	25%
ON/OFF Differential ² Output 1 only	d.F1	0.1% to 10.0% of input span	0.5%
Output 2 only ⁵	d.F2		
Outputs 1 & 2 ⁵	d.FF		
Setpoint High Limit	SPH1	Setpoint to Range Maximum	Range Maximum
Setpoint Low Limit	SPL0	Range Minimum to Setpoint	Range Minimum
Remote Setpoint Max. ¹¹	rSPH	-1999 to 9999	PV Range Max.
Remote Setpoint Min. ¹¹	rSPL	-1999 to 9999	PV Range Min.
Remote Setpoint Offset ¹¹	rSP0	-1999 to 9999	0
Recorder Output Scale Max.	rOPH	-1999 to 9999	Range Maximum
Recorder Output Scale Min.	rOPL	-1999 to 9999	Range Minimum
Output 1 Power Limit ¹	OPH1	0% to 100% of full power	100%
Output 1 Cycle Time	CT1	0.5, 1, 2, 4, 8, 16, 32, 64, 128, 256 or 512 secs.	32 secs.
Output 2 Cycle Time	CT2	0.5, 1, 2, 4, 8, 16, 32, 64, 128, 256 or 512 secs.	32 secs.
Process High Alarm 1 value ³	HAI	Range Min. To Range Max.	Range Max.
Process Low Alarm 1 value ³	LAI	Range Min. To Range Max.	Range Min.
Band Alarm 1 value ³	BAI	0 to span from Setpoint	5 units
Deviation Alarm 1 value ³	DAI	±Span from Setpoint	5 units
Alarm 1 Hysteresis	AHY1	1 LSD to 10% of span, expressed as display units	1 LSD

Table 2-1 Set Up Mode Parameters (cont.)

Parameter	Legend	Adjustment Range	Default Value
Process High Alarm 2 value ³	h_A2	Range Min. To Range Max.	Range Max.
Process Low Alarm 2 value ³	L_A2	Range Min. To Range Max.	Range Min.
Band Alarm 2 value ³	b_A2	0 to span from Limit SP	5 units
Deviation Alarm 2 value ³	d_A2	±Span from Limit SP	5 units
Alarm 2 Hysteresis	AH2	1 LSD to 10% of span, expressed as display units	1 LSD
Loop Alarm Enable	LAEn	0 (Disabled) or 1 (Enabled)	0
Loop Alarm Time ⁶	LAET	1s to 99m 59s	99m 59s
Scale Range Decimal Point ⁴	rPnt	0, 1, 2 or 3	1
Scale Range Maximum ⁴	rhi	-1999 to 9999	1000
Scale Range Minimum ⁴	rLo	-1999 to 9999	0000
Auto Pre-Tune Enable/Disable	APTE	0 (Disabled) or 1 (Enabled)	0
Manual Control Enable/Disable	POEn	0 (Disabled) or 1 (Enabled)	0
Setpoint Ramp Enable/Disable	rPEn	0 (Disabled) or 1 (Enabled)	0
Setpoint Strategy	SPSt	1, 2, 3, 4 or 5	1
Communications Enable ⁸	CoEn	0 (Disabled) or 1 (Enabled)	1 (Enabled)
Lock Code	Loc	0 to 9999	10
Operator Mode Displays (still accessible in Set Up Mode):			
Process Variable		Read Only	-
Setpoint ¹⁰	SP	Setpoint Low Limit to Setpoint High Limit	Setpoint Low Limit
Ramping Setpoint value ⁷	SPrP	Read only	
Setpoint Ramp Rate ⁹	rP	1 to 9999 and OFF	OFF (blank)
Alarm Status	ALSt	Read Only	-

NOTES ON TABLE 2-1

1. These parameters are not operative if the Proportional Band = 0.
2. Switching differential with ON/OFF control output.
3. These parameters are optional; only one legend will appear for each alarm.
4. Only applicable if a DC linear output is fitted.
5. Only applicable if Output 2 is fitted.
6. Only applicable if Proportional Band = 0.
7. Appears only if ramp rate is not switched OFF.
8. Applicable only if the Communications Option PCB is fitted.
9. Does not appear in Operator Mode unless **rPEn** = 1.
10. For Dual Setpoint operation, = **SP1** or **SP2**; for Remote Setpoint operation = **LSP** or **rSP**.
11. Appears only if Remote Setpoint operation is selected.
12. PB1 and PB2 cannot be set to less than 0.5% if the **RaPID** feature is engaged.

2.2.4 Output Power 2

This parameter is the current Output 2 power level (if Output 2 is fitted). It is a “Read Only” parameter and is not adjustable.

2.2.5 Proportional Band 1

This parameter is the portion of the input span of the Controller over which the Output 1 power level is proportional to the displayed process variable value. The function of Proportional Band 1 is illustrated in Figure 2-1.

2.2.6 Proportional Band 2

This parameter is the portion of the input span of the Controller over which the Output 2 power level is proportional to the displayed process variable value. In Figure 3-2, Proportional Band 2 is shown (a) with a non-zero value (Case 1 and Case 2) - PID control, and (b) with a zero value (Case 3) - ON/OFF control.

2.2.7 Reset (Integral Time Constant)

This parameter is adjustable in the range 1 second to 99 minutes 59 seconds and OFF (value greater than 99 minutes 59 seconds). This parameter is not applicable if Proportional Band 1 (see Subsection 2.2.5) is set to 0 (ON/OFF control).

2.2.8 Rate (Derivative Time Constant)

This parameter is adjustable in the range 00 seconds to 99 minutes 59 seconds. This parameter is not applicable if Proportional Band 1 (see Subsection 2.2.5) is set to 0 (ON/OFF control).

2.2.9 Overlap/Deadband

This defines the portion of the Proportional Band (Proportional Band 1 + Proportional Band 2) over which both outputs are active (or, in the case of a deadband, neither output is active). It is adjustable within the range -20% to +20% (negative value = deadband). The function of the overlap/deadband is illustrated in Figure 2-1.

Note that, with Output 2 set to ON/OFF control (Figure 2-1 Case 3), the Overlap/Deadband parameter has the effect of moving the ON Differential band of Output 2 to create an overlap (positive values) or a deadband (negative values). When Overlap/Deadband = 0, the “Output 2 OFF” edge of the Output 2 ON/OFF Differential band coincides with the point at which Output 1 reaches 0%.

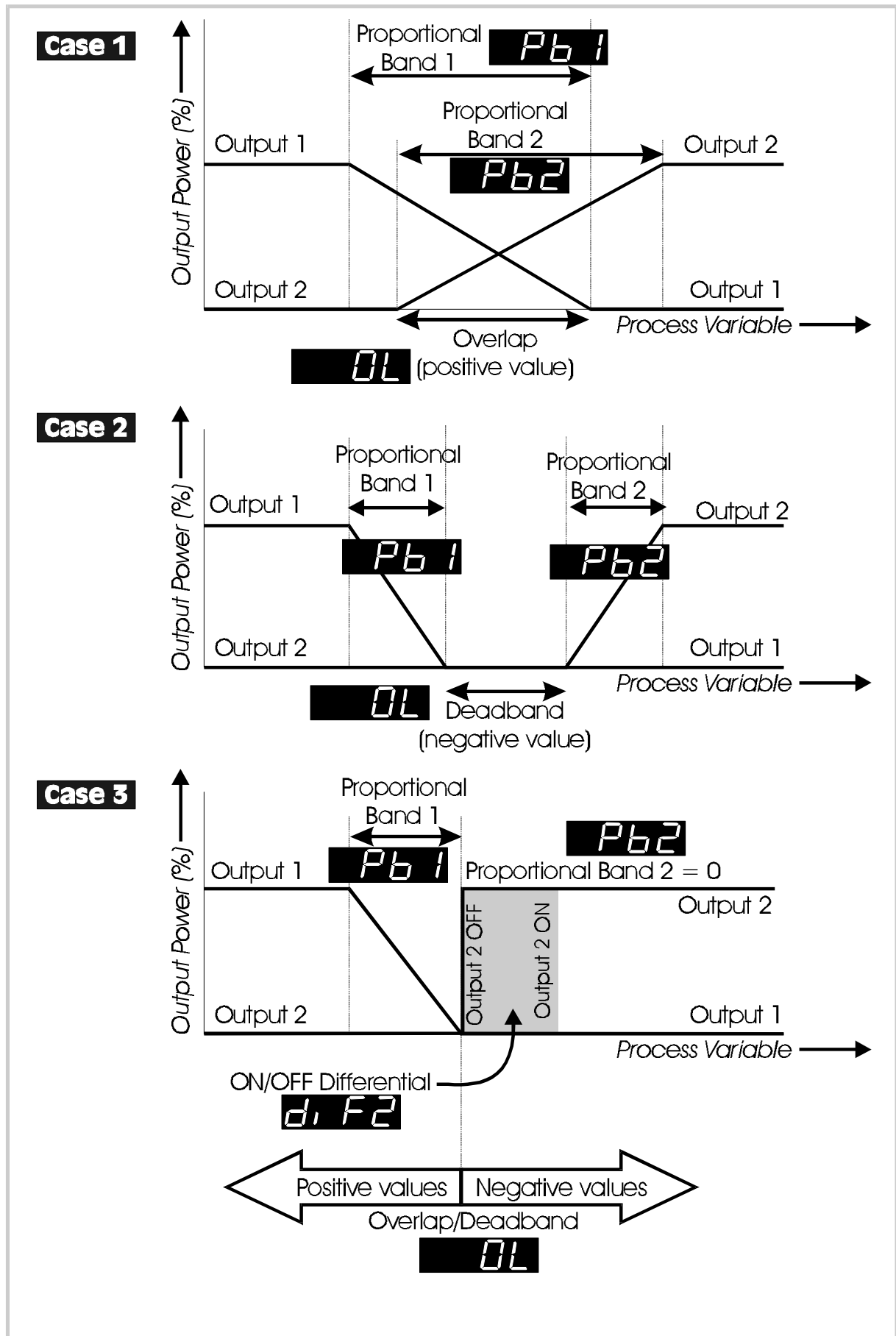

Figure 2-1 Proportional Band and Deadband/Overlap

2.2.10 Bias (Manual Reset)

This bias to the output power is expressed as a percentage of output power. This parameter is not applicable if Proportional Band 1 = 0.

2.2.11 ON/OFF Differential

This is a switching differential used when one or both outputs have been set to ON/OFF control (i.e. Proportional Band 1 or Proportional Band 2 or both = 0).

2.2.12 Setpoint High Limit

This is the maximum limit for setpoint adjustment. It should be set to a value which prevents the setpoint being given a value which will cause damage to the process being controlled.

2.2.13 Setpoint Low Limit

This is the minimum limit for setpoint adjustment. It should be set to a value which prevents the setpoint being given a value which will cause damage to the process being controlled.

2.2.14 Remote Setpoint Maximum

This, and the Remote Setpoint Minimum parameter (see below) define the scaling of the RSP input (which is a linear input). After scaling, the RSP value range is limited by the Setpoint High Limit. Thus, if the scaled RSP value is greater than the Setpoint High Limit, the RSP value will be clamped to the Setpoint High Limit.

2.2.15 Remote Setpoint Minimum

This, and the Remote Setpoint Maximum parameter (see above) define the scaling of the RSP input (which is a linear input). After scaling, the RSP value range is limited by the Setpoint High Limit and Setpoint Low Limit. Thus, if the scaled RSP value is less than the Setpoint Low Limit, the RSP value will be clamped to the Setpoint Low Limit.

2.2.16 Remote Setpoint Offset

This parameter is used to modify the remote setpoint value in the following manner:

Offset remote setpoint value = setpoint value + remote setpoint offset value.

2.2.17 Recorder Output Scale Maximum

This parameter defines the value of process variable or setpoint (whichever is applicable) at which the Recorder Output reaches its maximum value; for example, for a 0 - 5V Recorder Output, this value corresponds to 5V. The decimal point position for the Recorder Output is always the same as that for the process variable input range. This parameter is not applicable if the Recorder Output option is not fitted.

2.2.18 Recorder Output Scale Minimum

This parameter defines the value of the process variable or setpoint (whichever is applicable) at which the Recorder Output reaches its minimum value; for example, for a 0 - 5V Recorder Output, this value corresponds to 0V. The decimal point position for the Recorder Output is always the same as that for the process variable input range. This parameter is not applicable if the Recorder Output option is not fitted.

2.2.19 Output 1 Power Limit

This parameter is used to limit the power level of Output 1 and may be used to protect the process being controlled. If no protection is required, this parameter may be set to 100% (the default value). This parameter is not applicable if Proportional Band 1 is set to 0.

2.2.20 Output 1 Cycle Time

The cycle time value required is dependent upon the process being controlled and the type of output being used for Output 1. For a Relay Output, the cycle time should be as large as possible (whilst remaining compatible with the process control requirements) in order to maximise relay life. For an SSR Drive Output or Solid State Output, the cycle time may have a lower value (and thus satisfy the requirements of a fast-change process variable e.g. flow or pressure). This parameter is not applicable if Proportional Band 1 is set to 0 or if Output 1 is a DC linear output.

2.2.21 Output 2 Cycle Time

The cycle time value required is dependent upon the process being controlled and the type of output being used for Output 2. For a Relay Output, the cycle time should be as large as possible (whilst remaining compatible with the process control requirements) in order to maximise relay life. For an SSR Drive Output or Solid State Output, the cycle time may have a lower value (and thus satisfy the requirements of a fast-change process variable e.g. flow or pressure). This parameter is not applicable if Proportional Band 1 or Proportional Band 2 is set to 0 or if Output 2 is not fitted or is a DC linear output.

2.2.22 Process High Alarm 1 Value

This parameter, applicable only when Alarm 1 is selected to be a Process High alarm, defines the process variable value at or above which Alarm 1 will be active. The operation of a process high alarm is illustrated in Figure 2-2.

2.2.23 Process Low Alarm 1 Value

This parameter, applicable only when Alarm 1 is selected to be a Process Low alarm, defines the process variable value at or below which Alarm 1 will be active. The operation of a process low alarm is illustrated in Figure 2-2.

2.2.24 Band Alarm 1 Value

This parameter, applicable only if Alarm 1 is selected to be a Band Alarm, defines a band of process variable values, centred on the setpoint value. If the process variable value is outside this band, the alarm will be active. The operation of a band alarm is illustrated in Figure 2-2.

2.2.25 Deviation (High/Low) Alarm 1 Value

This parameter, applicable only if Alarm 1 is selected to be a Deviation High/Low Alarm, defines a value above (positive value - Deviation High alarm) or below (negative value - Deviation Low alarm) the setpoint; if the process variable deviates from the setpoint by a margin greater than that defined by this parameter, Alarm 1 goes active. The operation of Deviation Alarms is illustrated in Figure 2-2.

2.2.26 Alarm 1 Hysteresis

This parameter applies a hysteresis band on the "safe" side of the Alarm 1 value. Thus, Alarm 1 will become active when the Alarm 1 value is exceeded; Alarm 1 will become inactive when the process variable value is outside the hysteresis band on the "safe" side of the Alarm 1 value. The effect of the hysteresis value on the operation of the different types of alarm is illustrated in Figure 2-3.

2.2.27 Process High Alarm 2 Value

This parameter, applicable only when Alarm 2 is selected to be a Process High alarm, defines the process variable value at or above which Alarm 2 will be active. The operation of a process high alarm is illustrated in Figure 2-2.

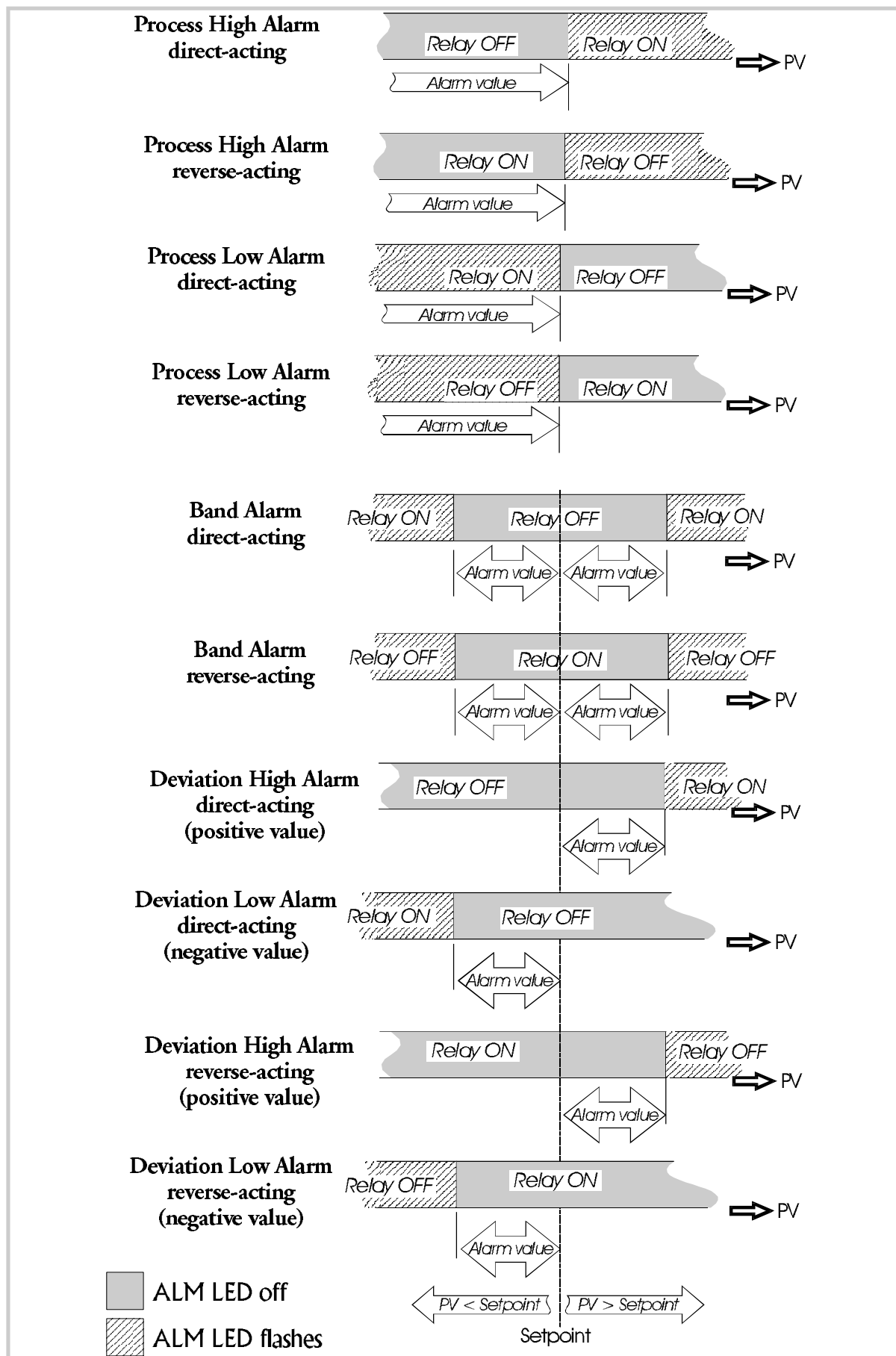

Figure 2-2 Alarm Operation

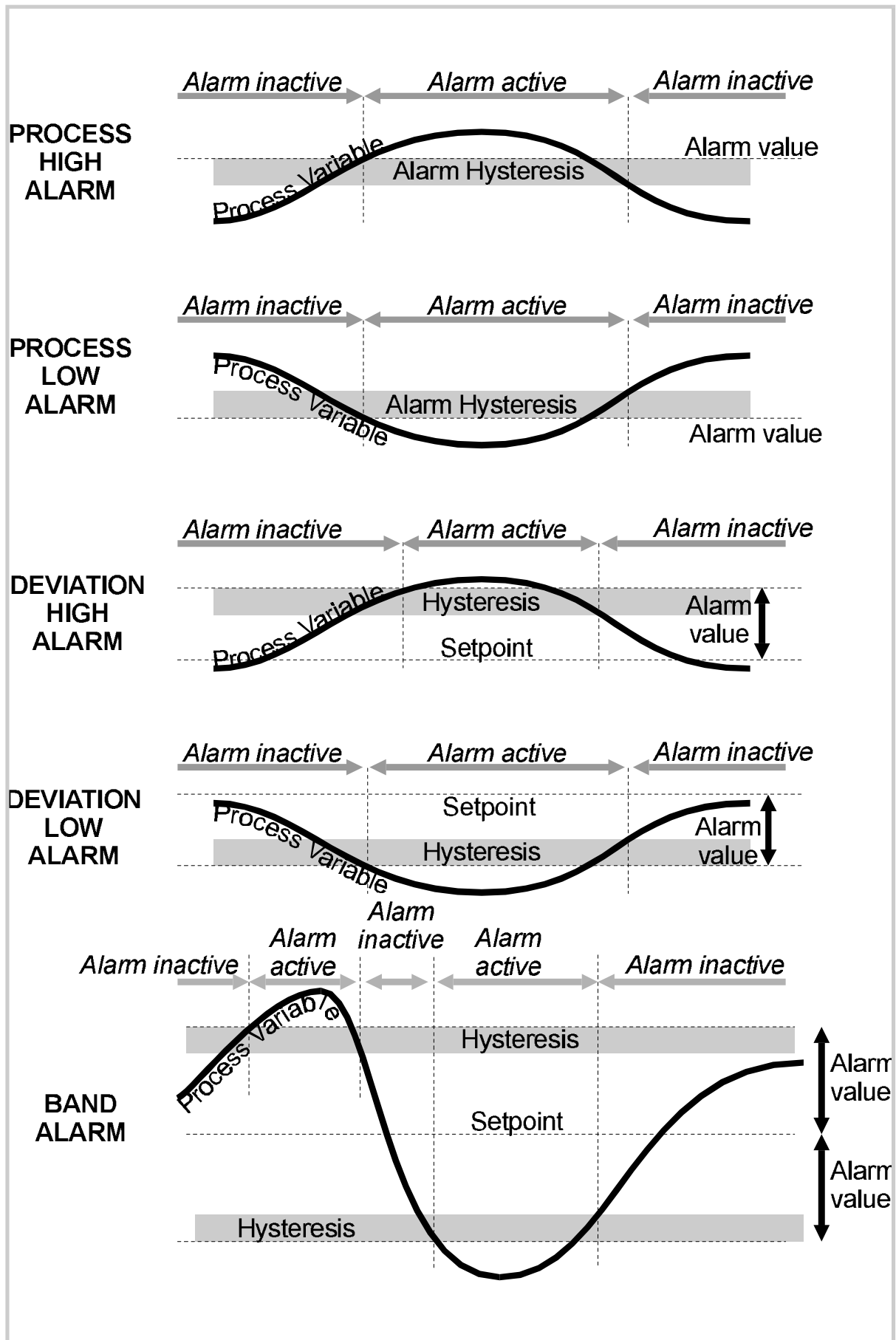

Figure 2-3 Alarm Hysteresis Operation

2.2.28 Process Low Alarm 2 Value

This parameter, applicable only when Alarm 2 is selected to be a Process Low alarm, defines the process variable value at or below which Alarm 2 will be active. The operation of a process low alarm is illustrated in Figure 2-2.

2.2.29 Band Alarm 2 Value

This parameter, applicable only if Alarm 2 is selected to be a Band Alarm, defines a band of process variable values, centred on the setpoint value. If the process variable value is outside this band, the alarm will be active. The operation of a band alarm is illustrated in Figure 2-2.

2.2.30 Deviation (High/Low) Alarm 2 Value

This parameter, applicable only if Alarm 2 is selected to be a Deviation High/Low Alarm, defines a value above (positive value - Deviation High alarm) or below (negative value - Deviation Low alarm) the setpoint; if the process variable deviates from the setpoint by a margin greater than that defined by this parameter, Alarm 2 goes active. The operation of Deviation Alarms is illustrated in Figure 2-2.

2.2.31 Alarm 2 Hysteresis

This parameter applies a hysteresis band on the “safe” side of the Alarm 2 value. Thus, Alarm 2 will become active when the Alarm 2 value is exceeded; Alarm 2 will become inactive when the process variable value is outside the hysteresis band on the “safe” side of the Alarm 2 value. The effect of the hysteresis value on the operation of the different types of alarm is illustrated in Figure 2-3.

2.2.32 Loop Alarm Enable

This parameter is the means by which the user can enable or disable the Loop Alarm. The Loop Alarm is a special alarm which detects faults in the control feedback loop by continuously monitoring process variable response to the control output(s).

The Loop Alarm facility, when enabled, repeatedly checks the control output(s) for saturation i.e. either or both outputs being at the maximum or minimum limit. If an output is found to be in saturation, the Loop Alarm facility starts a timer; thereafter, if the saturated output has not caused the process variable to be corrected by a pre-determined amount (V) after a time (Loop Alarm Time) has elapsed, the Loop Alarm goes active. Subsequently, the Loop Alarm facility repeatedly checks the process variable and the control output(s). When the process variable starts to change value in the correct sense or when the saturated output comes out of saturation, the Loop Alarm is de-activated.

For PID control, the Loop Alarm Time is always set to twice the value of the Reset (Integral Time Constant) parameter. For On/Off control, the value of the Loop Alarm Time parameter (see Subsection 2.2.33) is used. The value of V is dependent upon the input type:

°C ranges:	2°C or 2.0°C
°F ranges:	3°F or 3.0°F
Linear ranges:	10 least significant display units

For single output Controllers, the saturation limits are 0% and Out1Max%. For dual output Controllers, the saturation limits are -100% and Out1Max%.

NOTES:

1. Correct operation of the Loop Alarm depends upon reasonably accurate PID tuning.
2. The Loop Alarm is automatically disabled during Manual Control Mode and during execution of the Pre-Tune facility. Upon exit from Manual Control Mode or after completion of the Pre-Tune routine, the Loop Alarm is automatically re-enabled (if selected).

2.2.33 Loop Alarm Time

When full ON/OFF control is selected (i.e. Proportional Band 1 is set to 0) and Loop Alarm is enabled, this parameter determines the duration of the saturation condition after which the Loop Alarm will be activated. This parameter is omitted from the Set Up display sequence if ON/OFF control is not selected or Loop Alarm is disabled.

2.2.34 Scale Range Decimal Point

This parameter, applicable only if a linear primary input is fitted, defines the position of the decimal point in values of the process variable, setpoint, alarm levels and recorder outputs as shown on the right.

Value	Decimal Point Position
0	XXXX
1	XXX.X
2	XX.XX
3	X.XXX

2.2.35 Scale Range Maximum

This parameter, applicable only if a linear primary input is fitted, defines the scaled input value when the process variable input hardware is at its maximum value. This parameter can be set to a value less than (but not equal to) Scale Range Minimum, in which case the sense of the input is reversed.

2.2.36 Scale Range Minimum

This parameter, applicable only if a linear primary input is fitted, defines the scaled input value when the process variable input hardware is at its minimum value. This parameter can be set to a value greater than (but not equal to) Scale Range Maximum, in which case the sense of the input is reversed.

2.2.37 Auto Pre-Tune Enable/Disable

This parameter determines whether or not the Controller's Pre-Tune facility is activated automatically on power-up or not (0 = Disabled, 1 = Enabled).

2.2.38 Manual Control Enable/Disable

This parameter determines whether operator selection of manual control is enabled or disabled (0 = Disabled, 1 = Enabled).

NOTE: When selection is disabled (=0), it is not possible to switch into *or out* of Manual Control Mode.

2.2.39 Setpoint Ramp Enable/Disable

This parameter enables/disables use of the setpoint ramping feature at user level (0 = Disabled, 1 = Enabled).

2.2.40 Setpoint Strategy

This parameter enables the user to select the required Operator Mode setpoint display strategy, as shown in Subsection 1.1.

2.2.41 Communications Enable/Disable

This parameter enables/disables Write operations (i.e. the *changing* of parameter values/settings) via the RS485 communications link, if the Communications Option PCB is fitted (0 = Disabled, 1 = Enabled). Parameters can be *interrogated* via the link, regardless of the setting of this parameter.

2.2.42 Lock Value

This parameter defines the four-digit code required to enter Set Up Mode.

2.3 OPERATOR MODE DISPLAYS

Once the complete cycle of Set Up Mode parameters has been displayed, the user may then step through the Operator Mode displays (see Section 1), making

adjustments where required, before re-starting the Set Up Mode parameter cycle, as shown in Table 2-1.

2.4 TUNING THE CONTROLLER MANUALLY

2.4.1 Controllers Fitted with Output 1 Only

Before starting to tune the Controller to the load, check that the Setpoint High and Low Limits (**SPhi** and **SPLo**) are set to safe levels.

The following simple technique may be used to determine values for proportional band (**Pb1**), derivative time constant (**rAtE**) and integral time constant (**rSEt**).

NOTE: This technique is suitable for use only with processes which are not harmed by large fluctuations in the process variable. It provides an acceptable basis from which to start fine tuning for a wide range of processes.

1. Set the setpoint to the normal operating process value (set it to a lower value if overshoot beyond the normal operating process value is likely to cause damage).
2. Dis-engage the **RaPID** feature (see Subsection 1.11) if it is currently engaged.
3. Select ON/OFF Control (i.e. set **Pb1** = 0).
4. Switch on the process. Under these conditions, the process variable will oscillate about the setpoint and the following parameter values should be noted:
 - (a) The peak-to-peak variation (**P**) of the first cycle i.e. the difference between the highest value of the first overshoot and the lowest value of the first undershoot - see Figure 2-4)
 - (b) The cycle time (**T**) of this oscillation in minutes (see Figure 2-4)

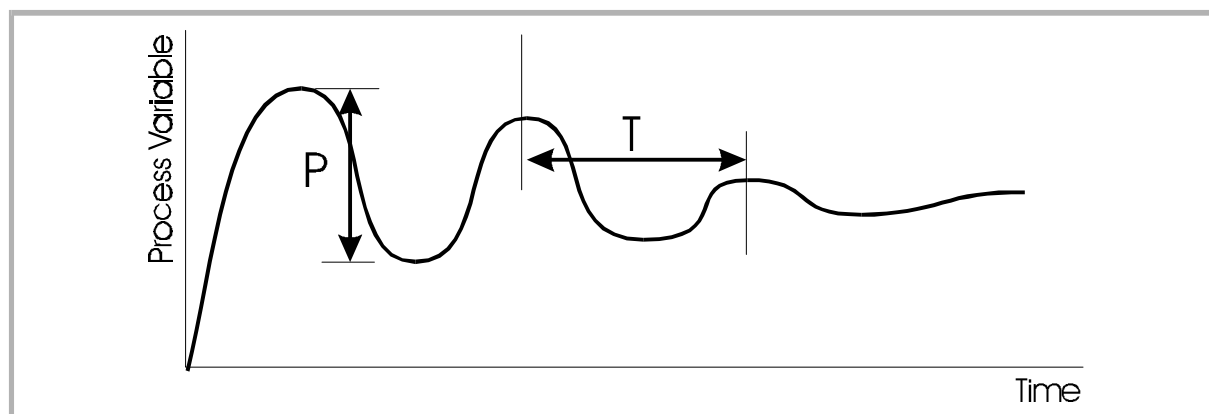

Figure 2-4 Manual Tuning Parameters (Output 1 only)

5. The control parameters should then be set at follows:

$$\mathbf{Pb1} = \frac{P}{ScaleRange} \times 100$$

$$\mathbf{rSET} = T \text{ minutes}$$

$$\mathbf{rAtE} = \frac{T}{6} \text{ minutes}$$

NOTE: After setting up the parameters, set the Controller to Operator Mode (see Subsection 2.5) to prevent unauthorised adjustment to the values.

2.4.2 Controllers Fitted with Output 1 and Output 2

Before starting to tune the Controller to the load, check that the Setpoint High and Low Limits (**SPhi** and **SPLo**) are set to safe levels.

The following simple technique may be used to determine values for proportional band (**Pb1**), derivative time constant (**rAtE**) and integral time constant (**rSEt**).

NOTE: This technique is suitable for use only with processes which are not harmed by large fluctuations in the process variable. It provides an acceptable basis from which to start fine tuning for a wide range of processes.

1. Tune the Controller using Output 1 only as described in Subsection 2.4.1.
2. Set **Pb2** to the same value as **Pb1** and monitor the operation of the Controller in dual output mode. If there is a tendency to oscillate as control passes into the Output 2 proportional band, increase the value of **Pb2**. If the process appears to be over-damped in the region of the Output 2 proportional band, decrease the value of **Pb2**.
3. When values of proportional bands, integral time constant and derivative time constant have been determined for tuning, if there is a "kick" as control passes from one output to the other, set **OL** to a positive value to introduce some overlap. Adjust the value of **OL** by trial and error until satisfied.

2.5 EXIT FROM SET UP MODE

To leave Set Up Mode, select the initial Operator Mode display (normally process variable) then depress the Raise and Function keys simultaneously, whereupon the Controller will return to Operator Mode. NOTE: An automatic return to Operator mode will be executed if there is no key activity in Set Up Mode for two minutes.

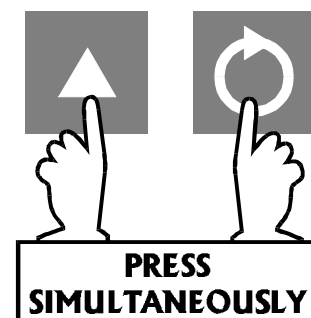

3 RS485 SERIAL COMMUNICATIONS

The RS485-compatible serial communications option provides the means for communication between the Controller and a master device (e.g. a computer or terminal). *This may be used on two-wire systems or three-wire systems.*

3.1 COMMUNICATIONS ENABLE/DISABLE

When Communications are enabled (in Set Up Mode - see Subsection 2.2.36), the Controller parameters may be adjusted by the master device via the serial communications link. If communications are disabled, the Controller will not adjust or change any parameters in response to commands received from the master device and will send a negative acknowledgement in response to such commands. Whether communications are enabled or disabled, the Controller will return the requested information in response to a Type 2 Interrogation message (see Subsection 3.2.5) from the master device.

3.2 PHYSICAL REQUIREMENTS

3.2.1 Character Transmission

Data format is fixed to be even parity, seven data bits and one stop bit. The Baud rate may be selected to be 1200, 2400, 4800 (default) or 9600 Baud.

3.2.2 Line Turn-Round

The communications link is operated as a multi-drop half duplex system. When a device is transmitting, it drives the transmission lines to the appropriate levels; when it is not transmitting, its outputs are set to a high impedance in order that another device can transmit. It is important that a transmitter releases the transmission lines before another device starts transmission. This imposes the following restraints on the master device:

(a) The transmitter must release the transmission lines within 6ms of the end of the last character of a message being transmitted. Note that delays due to buffers such as those used in universal asynchronous receivers/transmitters (UARTs) within the master device must be taken into account.

(b) The transmitter must not start transmission until 6ms has elapsed since the reception of the last character of a message.

All Controllers in this range having an RS485 communications facility adhere to this standard; thus, provided that the master device conforms similarly to the standard, there should be no line contention problems.

3.2.3 Communications Protocol

The protocol assumes half duplex communications. All communication is initiated by the master device. The master sends a command or query to the addressed slave and the slave replies with an acknowledgement of the command or the reply to the query. All messages, in either direction, comprise:

- (a) A Start of Message character
- (b) One or two address characters (uniquely defining the slave)
- (c) A parameter/data character string
- (d) An End of Message character

Messages from the master device may be one of four types:

- Type 1: L {N} ? ? *
- Type 2: L {N} {P} {C} *
- Type 3: L {N} {P} # {DATA} *
- Type 4: L {N} {P} I *

Table 3-1 {DATA} Element - Sign and Decimal Point

{DATA} Content	Sign/Decimal Point
abcd0	+abcd
abcd1	+abc.d
abcd2	+ab.cd
abcd3	+a.bcd
abcd5	-abcd
abcd6	-abc.d
abcd7	-ab.cd
abcd8	-a.bcd

where all characters are in ASCII code and:

- L is the Start of Message character (Hex 4C)
- {N} is the slave Controller address (in the range 1 - 32); addresses 1 - 9 may be represented by a single digit (e.g. 7) or in two-digit form, the first digit being zero (e.g. 07).
- {P} is a character which identifies the parameter to be interrogated/modified.
- {C} is the command (see below)
- # indicates that {DATA} is to follow (Hex 23)
- {DATA} is a string of numerical data in ASCII code (see Table 3-1)
- * is the End of Message character (Hex 2A)

No space characters are permitted in messages. Any syntax errors in a received message will cause the slave controller to issue no reply and await the Start of Message character.

3.2.4 Type 1 Message

$$L \{N\} \ ? \ ? \ ? \ *$$

This message is used by the master device to determine whether the addressed slave Controller is active. The reply from the slave Controller, if it is active, is

$$L \{N\} \ ? \ A \ *$$

An inactive Controller will give no reply.

3.2.5 Type 2 Message

$$L \{N\} \ \{P\} \ \{C\} \ *$$

This type of message is used by the master device to interrogate or modify a parameter in the addressed Controller. {P} identifies the parameter and {C} represents the command to be executed, which may be one of the following:

- + (Hex 2B) - Increment the value of the parameter defined by {P}
- (Hex 2D) - Decrement the value of the parameter defined by {P}
- ? (Hex 3F) - Determine the current value of the parameter defined by {P}

The reply from the addressed Controller is of the form:

$$L \{N\} \ \{P\} \ \{DATA\} \ A \ *$$

where {DATA} comprises five ASCII-coded digits whose format is shown in Table 3-1. The data is the value requested in a query message or the new value of the parameter after modification. If the action requested by the message from the master device would result in an invalid value for that parameter (either because the requested new value would be outside the permitted range for that parameter or because the parameter is not modifiable), the Controller replies with a negative acknowledgement:

$$L \{N\} \ \{P\} \ \{DATA\} \ N \ *$$

The {DATA} string in the negative acknowledgement reply will be indeterminate. If the process variable or the deviation is interrogated whilst the process variable is outside the range of the Controller, the reply is $L\{N\}\{P\} <??> 0A^*$ if the process variable is over-range, or $L\{N\}\{P\} <??> 5A^*$ if the process variable is under-range.

Scan Tables

A parameter identifier character "]" in the message from the master device indicates that a "Scan Table" operation is required. This provides a facility for

interrogating the values of a group of parameters and status in a single message from the master device. The reply to such a command would be in the form:

$$L \{N\}] xx aaaaa bbbbbb ccccc ddddd eeeee A *$$

where xx is the number of data digits to follow; this is 20 for a single-control-output instrument and 25 for a dual-control-output instrument. The digits are expressed as shown in Table 3-1. For further information, refer to Subsection 3.5.6.3.

3.2.6 Type 3 Message

$$L \{N\} \{P\} \# \{DATA\} *$$

This message type is used by the master device to set a parameter to the value specified in {DATA}. The command is not implemented immediately by the slave Controller; the slave will receive this command and will then wait for a Type 4 message (see below). Upon receipt of a Type 3 message, if the {DATA} content and the specified parameter are valid, the slave Controller reply is of the form:

$$L \{N\} \{P\} \{DATA\} I *$$

(where I = Hex 49) indicating that the Controller is ready to implement the command. If the parameter specified is invalid or is not modifiable or if the desired value is outside the permitted range for that parameter, the Controller replies with a negative acknowledgement in the form:

$$L \{N\} \{P\} \{DATA\} N *$$

3.2.7 Type 4 Message

$$L \{N\} \{P\} I *$$

This type of message is sent by the master device to the addressed slave Controller following a successful Type 3 message transmission and reply to/from the same slave Controller. Provided that the {DATA} content and the parameter specified in the preceding Type 3 message are still valid, the slave Controller will then set the parameter to the desired value and will reply in the form:

$$L \{N\} \{P\} \{DATA\} A *$$

where {DATA} is the new value of the parameter. If the new value or parameter specified is invalid, the slave Controller will give a negative acknowledgement:

$$L \{N\} \{P\} \{DATA\} N *$$

where {DATA} is indeterminate. If the immediately-preceding message received by the slave Controller was not a Type 3 message, the Type 4 message is ignored.

3.3 INDIVIDUAL PARAMETERS

The individual parameters and how they may be interrogated/modified are described below. Unless otherwise stated, the {DATA} element will follow the standard five-digit format and the decimal point position must be correct for the new value to be accepted and for modification to occur.

3.3.1 Input Parameters

Parameter	Identifier	Description
Process Variable	M	Read (Type 2 message) Only; If out of range, {DATA} will contain <??> 0 (over-range) or <??> 5 (under-range).
Process Variable Offset	v	May be read (Type 2 message) or modified (Type 3/Type 4 message sequence). Modifies actual process variable value (as measured at the input terminals): Modified PV value = Actual PV value + PV offset value Modified value is limited by Range Maximum and Range Minimum and is used for display/alarm purposes and for recorder outputs. <i>Choose this value with care. In effect, it modifies the Controller's calibration. Lack of care could result in the displayed PV value having no meaningful relationship to the actual PV value.</i>
Scale Range Max.	G	Adjustable only on DC inputs. May be read (Type 2 message) or modified (Type 3/Type 4 message sequence). Decimal point position is as for the input range. <i>If less than Scale Range Min. Value, sense of input is reversed.</i>
Scale Range Min.	H	Adjustable only on DC inputs. May be read (Type 2 message) or modified (Type 3/Type 4 message sequence). Decimal point position is as for the input range. <i>If greater than Scale Range Max. Value, sense of input is reversed.</i>
Scale Range Decimal Point	Q	Adjustable on DC inputs only. May be read (Type 2 message) or modified (Type 3/Type 4 message sequence). Defines the decimal point position: 0 = abcd 1 = abc.d 2 = ab.cd 3 = a.bcd
Input Filter Time Constant	m	May be read or modified using a Type 2 message or a Type 3/Type 4 message sequence.

3.3.2 Output Parameters

Parameter	Identifier	Description
Power Output value	W	If Manual Control is not selected, may be read only (Type 2 message). If Manual Control is selected, may be read (Type 2 message) or modified (Type 3/Type 4 message sequence).
Output 1 Power Limit	B	May be read (Type 2 message) or modified (Type 3/Type 4 message sequence). Defines power limit for Output 1.
Output 1 Cycle Time	N	May be read (Type 2 message) or modified (Type 3/Type 4 message sequence). NOTE: Value must be a power of 2 in the range 0.5 - 512 (i.e. 0.5, 1, 2, 4, 8 etc.). For a Relay Output, cycle time should be as large as possible (whilst remaining compatible with the process control requirements) in order to maximise relay life. For an SSR Output, the cycle time may have a lower value (and thus satisfy the requirements of a fast-changing process variable e.g. flow or pressure).
Output 2 Cycle Time	O	May be read (Type 2 message) or modified (Type 3/Type 4 message sequence). NOTE: Value must be a power of 2 in the range 0.5 - 512 (i.e. 0.5, 1, 2, 4, 8 etc.). For a Relay Output, cycle time should be as large as possible (whilst remaining compatible with the process control requirements) in order to maximise relay life. For an SSR Output, the cycle time may have a lower value (and thus satisfy the requirements of a fast-changing process variable e.g. flow or pressure).
Recorder Output Scale Max.	[May be read/modified by a Type 2 message or a Type 3/Type 4 message sequence. Corresponds to Input Scale Max. with decimal point position as for input. If less than Recorder Output Scale Min. sense of recorder output is reversed.
Recorder Output Scale Min.	\	May be read/modified by a Type 2 message or a Type 3/Type 4 message sequence. Corresponds to Input Scale Min. with decimal point position as for input. If greater than Recorder Output Scale Max. sense of recorder output is reversed.

3.3.3 Setpoint (SP) Parameters

Parameter	Identifier	Description
Setpoint/SP1/ Local SP value	S	May be read (Type 2 message) or modified (Type 3/Type 4 message sequence). Limited by Setpoint High Limit and Setpoint Low Limit (see below).
Setpoint Ramp Rate	^	May be read (Type 2 message) or modified (Type 3/Type 4 message sequence). May be set in the range 1 - 9999 increments/hour or OFF ({DATA} =0000). Decimal point position is as for input range.
Setpoint High Limit	A	May be read (Type 2 message) or modified (Type 3/Type 4 message sequence). Defines maximum value for setpoint (in the range setpoint - Input Range Maximum). Decimal point position is as for input range.
Setpoint Low Limit	T	May be read (Type 2 message) or modified (Type 3/Type 4 message sequence). Defines minimum value for setpoint (in the range Input Range Minimum - setpoint). Decimal point position is as for input range.
Remote SP value	R	Accessible only in Remote Setpoint operation. May be read only by a Type 2 message.
Remote SP Max. Value	X	Accessible only in Remote Setpoint operation. May be read (Type 2 message) or modified (Type 3/Type 4 message sequence). This parameter and the Remote SP Minimum Value parameter define the scaling of the Remote SP (linear) input. After scaling, the Remote SP value range is limited by Setpoint High Limit and Setpoint Low Limit. Thus, if the scaled Remote SP value is greater than Setpoint High Limit, the Remote SP value is clamped to Setpoint High Limit.
Remote SP Min. Value	Y	Accessible only in Remote Setpoint operation. May be read (Type 2 message) or modified (Type 3/Type 4 message sequence). This parameter and the Remote SP Maximum Value parameter define the scaling of the Remote SP (linear) input. After scaling, the Remote SP value range is limited by Setpoint High Limit and Setpoint Low Limit. Thus, if the scaled Remote SP value is less than Setpoint Low Limit, the Remote SP value is clamped to Setpoint Low Limit.

Continued overleaf.....

Parameter	Identifier	Description
Remote SP Offset value	~	Accessible only in Remote Setpoint operation. May be read (Type 2 message) or modified (Type 3/Type 4 message sequence). Modifies the Remote Setpoint value as follows: Offset Remote SP = SP value + Remote SP Offset value
Setpoint 2 value	-	Accessible only in Dual Setpoint operation. May be read (Type 2 message) or modified (Type 3/Type 4 message sequence). Value limited by Setpoint High Limit and Setpoint Low Limit.
Setpoint Selection	s	In Dual Setpoint or Remote Setpoint operation only. Indicates the currently-active setpoint. May be read only (Type 2 message).

When the Setpoint Selection parameter is read, the {DATA} byte in the response is of the format:

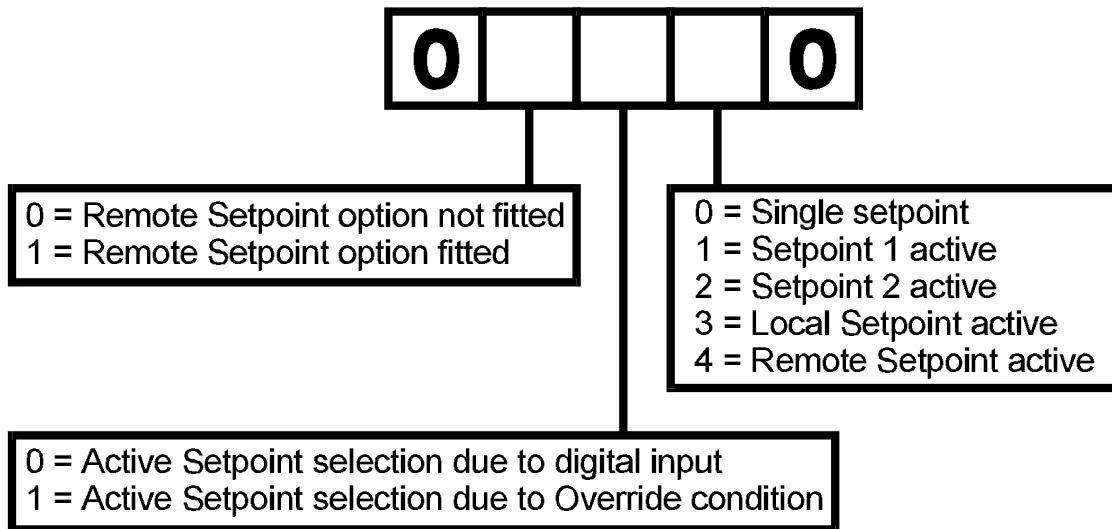

A Type 3/4 message sequence may be used to apply an Override condition; the {DATA} byte will define the setpoint selection:

{DATA} Byte	Effect
00110	Setpoint 1 is active (Dual Setpoint operation)
00120	Setpoint 2 is active (Dual Setpoint operation)
00130	Local Setpoint is active (Remote Setpoint operation)
00140	Remote Setpoint is active (Remote Setpoint operation)

A {DATA} byte content of 00130/00140 in Dual Setpoint operation or 00110/00120 in Remote Setpoint operation will cause a negative acknowledgement to be returned. Any attempt to change the setpoint selection with a Type 2 message will cause a negative acknowledgement to be returned.

An Override condition may be cancelled by a Type 3/4 message sequence with one of the following {DATA} byte contents (whichever is applicable):

{DATA} Byte	Effect
00010	Cancel Override selection of Setpoint 1
00020	Cancel Override selection of Setpoint 2
00030	Cancel Override selection of Local Setpoint
00040	Cancel Override selection of Remote Setpoint

3.3.4 Alarm Parameters

Parameter	Identifier	Description
Alarm 1 value	C	May be read/modified by a Type 2 message or a Type 3/Type 4 message sequence. Decimal point position is as for input range.
Alarm 1 Hysteresis value	a	Applies a hysteresis band on the "safe" side of the Alarm 1 value. May be read/modified by a Type 2 message or a Type 3/Type 4 message sequence.
Alarm 2 value	E	May be read/modified by a Type 2 message or a Type 3/Type 4 message sequence. Decimal point position is as for input range.
Alarm 2 Hysteresis value	b	Applies a hysteresis band on the "safe" side of the Alarm 2 value. May be read/modified by a Type 2 message or a Type 3/Type 4 message sequence.

For descriptions of the operation of the different alarm types, see Figure 2-2.

3.3.5 Tuning Parameters

Parameter	Identifier	Description
Rate (Derivative Time Constant)	D	May be read/modified using a Type 2 message or a Type 3/Type 4 message sequence. Defines the derivative time constant for the control algorithm. {DATA} is of the form mm.ss where mm = minutes and ss = seconds. The decimal point position must specify two decimal places, otherwise modification will not occur. ³
Reset (Integral Time Constant)	I	May be read/modified using a Type 2 message or a Type 3/Type 4 message sequence. Defines the integral time constant for the control algorithm. {DATA} is of the form mm.ss where mm = minutes and ss = seconds. The decimal point position must specify two decimal places, otherwise modification will not occur. ^{1,3}
Manual Reset (Bias)	J	May be read/modified using a Type 2 message or a Type 3/Type 4 message sequence. Decimal point position is as for input range.
ON/OFF Differential	F	May be read/modified using a Type 2 message or a Type 3/Type 4 message sequence. Defines the switching hysteresis for controllers with an ON/OFF control output. Decimal point position = 1.
Overlap /Deadband	K	May be read/modified using a Type 2 message or a Type 3/Type 4 message sequence. May be set to a positive (overlap) or negative (deadband) value. Decimal point position = 0. ²
Proportional Band 1 value	P	May be read/modified using a Type 2 message or a Type 3/Type 4 message sequence. May be set to 0.0 (ON/OFF control) or within the range 0.5% - 999.9% of Output 1 power range. Decimal point position = 1. ³
Proportional Band 2 value	U	May be read/modified using a Type 2 message or a Type 3/Type 4 message sequence. May be set to 0.0 (ON/OFF control) or within the range 0.5% - 999.9% of Output 2 power range. Decimal point position = 1. ^{2,3}

NOTES:

1. If Controller is in ON/OFF Control Mode (i.e. Proportional Band 1 = 0) and Loop Alarm is enabled (see Subsection 2.2.27), a message with identifier I will have effect on the Loop Alarm Time parameter, not the Integral Time Constant.
2. Not applicable to Controllers with only one control output.
3. These parameters cannot be adjusted whilst Pre-Tune or Self-Tune is active.

3.3.6 Status Parameters

Parameter	Identifier	Description
Controller Status Byte 1	L	Read Only (Type 2 message). Status information is encoded in four digits as the decimal representation of a binary number; each bit in the binary number has a particular significance (see Figure 3-1).
Controller Status Byte 2	V	Read Only (Type 2 message). Status information is encoded in four digits as the decimal representation of a binary number; each bit in the binary number has a particular significance (see Figure 3-1).
Arithmetic Deviation	V	Read Only (Type 2 message). The difference between the process variable value and the current Setpoint value.
Scan Tables]	<p>Read Only (Type 2 message). Response: L{N}xxaaaaabbbbbccccccddddddeeeeeA*</p> <p>where:</p> <ul style="list-style-type: none"> xx = Number of data digits in {DATA} element (20 for single control output, 25 for dual control outputs) aaaaa = Current setpoint value bbbbbb = Current process variable value cccccc = Current value of Output 1 Power (0 - 100%) dddddd = Current value of Output 2 Power (0 - 100%) - if applicable. eeeeee = Controller Status (see Figure 3-1)

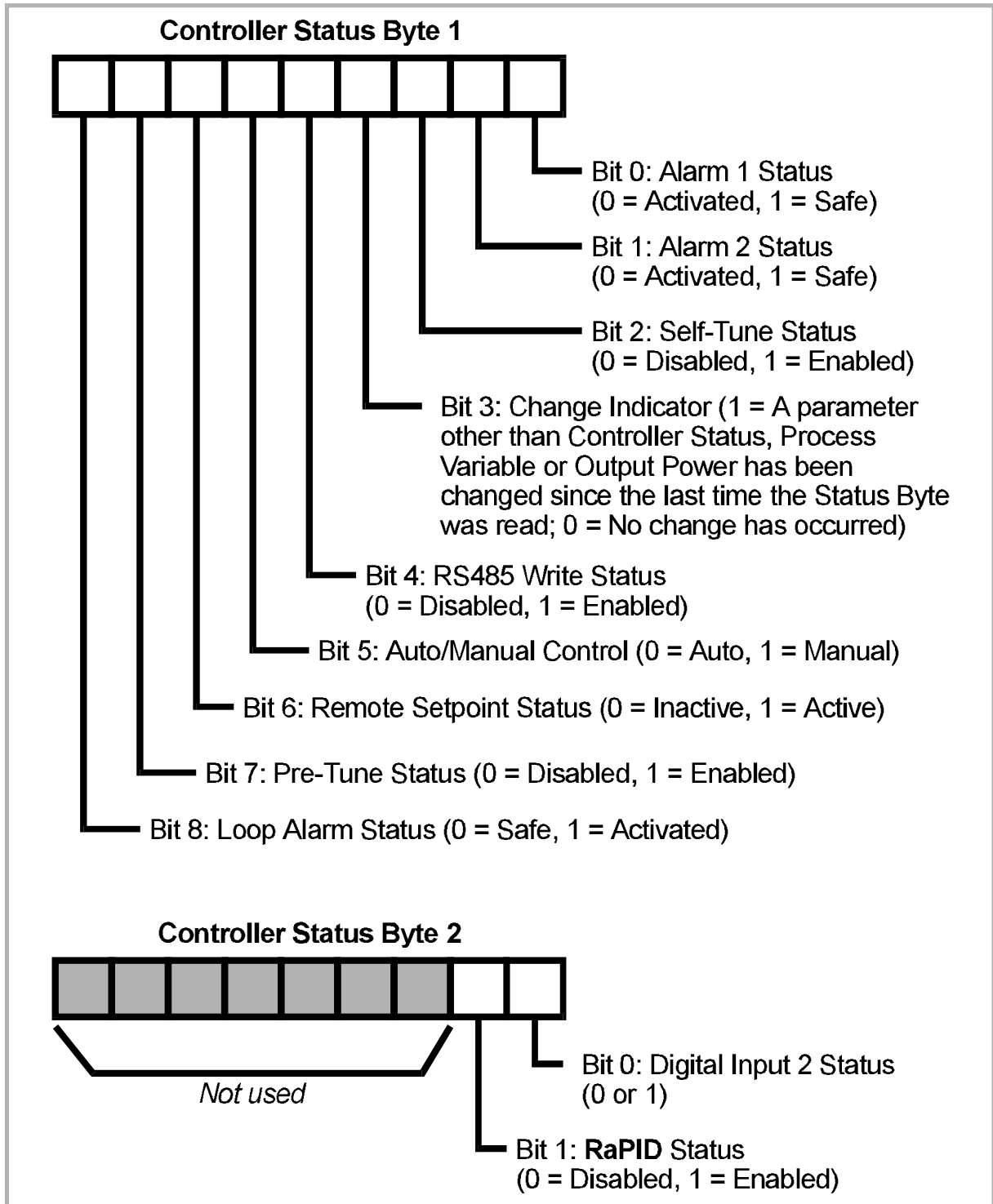

Figure 3-1 Controller Status Bytes

3.3.7 Controller Commands

Parameter	Identifier	Description																
Controller Commands	Z	<p>Implemented by Type 3/Type 4 message sequence only. In the Type 3 message, {DATA} must be one of eight five-digit numbers:</p> <table> <tbody> <tr> <td>00010</td> <td>Activate Manual Control</td> </tr> <tr> <td>00020</td> <td>Activate Automatic Control</td> </tr> <tr> <td>00030</td> <td>Activate Self-Tune</td> </tr> <tr> <td>00040</td> <td>De-activate Self-Tune</td> </tr> <tr> <td>00050</td> <td>Request Pre-Tune*</td> </tr> <tr> <td>00060</td> <td>Abort Pre-Tune</td> </tr> <tr> <td>00130</td> <td>Activate Loop Alarm</td> </tr> <tr> <td>00140</td> <td>De-activate Loop Alarm</td> </tr> </tbody> </table> <p>The response from the Controller also contains the same {DATA} content, as does the response to the Type 4 message.</p>	00010	Activate Manual Control	00020	Activate Automatic Control	00030	Activate Self-Tune	00040	De-activate Self-Tune	00050	Request Pre-Tune*	00060	Abort Pre-Tune	00130	Activate Loop Alarm	00140	De-activate Loop Alarm
00010	Activate Manual Control																	
00020	Activate Automatic Control																	
00030	Activate Self-Tune																	
00040	De-activate Self-Tune																	
00050	Request Pre-Tune*																	
00060	Abort Pre-Tune																	
00130	Activate Loop Alarm																	
00140	De-activate Loop Alarm																	

* Pre-Tune will be activated only if the process variable is at least 5% of input span from the setpoint.

3.4 ERROR RESPONSE

The circumstances under which a message received from the master device is ignored are:

- Parity error detected
- Syntax error detected
- Timeout elapsed
- Receipt of a Type 4 message without a preceding Type 3 command message.

Negative acknowledgements will be returned if, in spite of the received message being notionally correct, the Controller cannot supply the requested information or perform the requested operation. The {DATA} element of a negative acknowledgement will be indeterminate.

$\frac{1}{4}$ -DIN & $\frac{1}{8}$ -DIN RaPID TEMPERATURE CONTROLLERS

PRODUCT MANUAL

VOLUME II INSTALLATION & CONFIGURATION INSTRUCTIONS



The procedures described in this Volume must be undertaken only by technically-competent servicing personnel.

Contents

1	INSTALLATION	1-1
1.1	UNPACKING PROCEDURE	1-1
1.2	PANEL-MOUNTING THE CONTROLLER	1-1
1.3	CONNECTIONS AND WIRING	1-3
2	INTERNAL LINKS AND SWITCHES	2-1
2.1	REMOVING THE CONTROLLER FROM ITS HOUSING	2-1
2.2	REMOVING/REPLACING THE OUTPUT 2/OUTPUT 3 OPTION PCBs	2-2
2.3	REMOVING/REPLACING THE RS485 SERIAL COMMUNICATIONS OPTION PCB OR DUAL SETPOINT OPTION PCB	2-3
2.4	REPLACING THE CONTROLLER IN ITS HOUSING	2-3
2.5	SELECTION OF INPUT TYPE	2-4
2.6	SECONDARY ANALOGUE INPUT TYPE SELECTION	2-4
2.7	SELECTION OF PRIMARY OUTPUT (OUTPUT 1) TYPE	2-5
2.8	OUTPUT 2 TYPE/OUTPUT 3 TYPE	2-6

3	CONFIGURATION MODE	3-1
3.1	ENTRY INTO CONFIGURATION MODE	3-1
3.2	HARDWARE DEFINITION CODE/OPTION SELECTION/SECOND INPUT USAGE	3-2
3.3	CONFIGURATION MODE PARAMETERS.	3-6
3.4	EXIT FROM CONFIGURATION MODE	3-10

Appendices

A	PRODUCT SPECIFICATION	A-1
B	RaPID CONTROL FEATURE	B-1
C	ALARM HYSTERESIS OUTPUT	C-1

1 INSTALLATION

1.1 UNPACKING PROCEDURE

1. Remove the Controller from its packing. The Controller is supplied with a panel gasket and push-fit fixing strap. Retain the packing for future use, should it be necessary to transport the Controller to a different site or to return it to the supplier for repair/testing.

2. Examine the delivered items for damage or deficiencies. If any is found, notify the carrier immediately.

1.2 PANEL-MOUNTING THE CONTROLLER

The panel on which the Controller is to be mounted must be rigid and may be up to 6.0mm (0.25 inches) thick. The cut-out required for a single Controller is as shown in Figure 1-1.

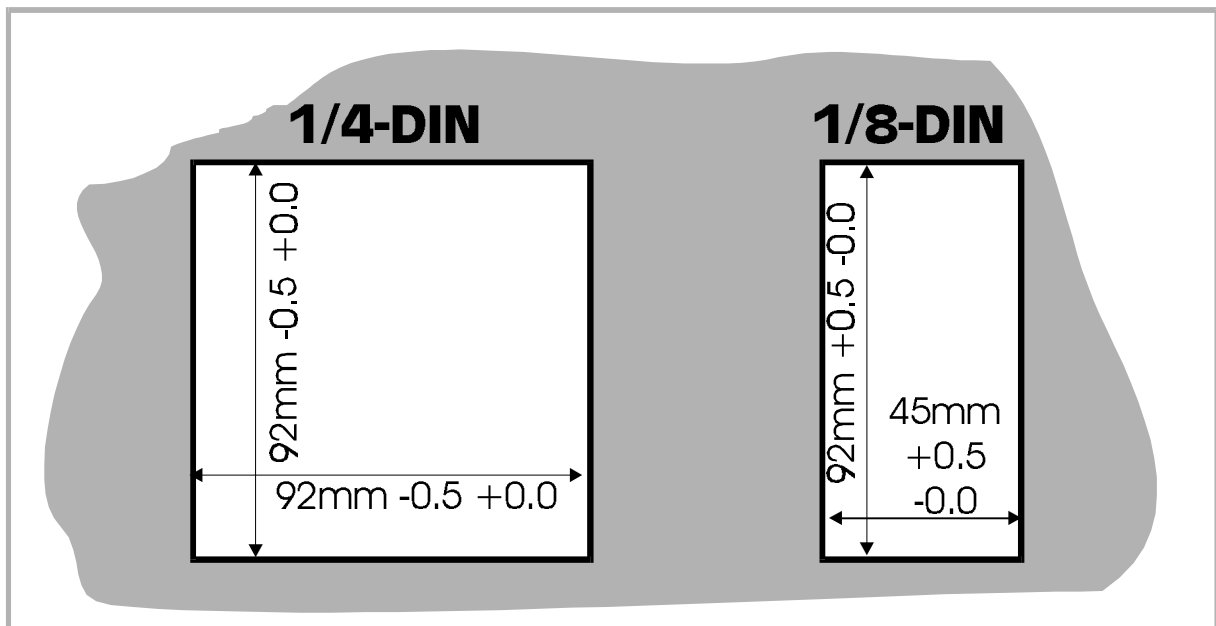

Figure 1-1 Panel Cutout Dimensions

Several controllers may be installed in a single cut-out, side-by-side. For n Controllers mounted side-by-side, the width of the cut-out would be:

$\frac{1}{8}$ -DIN Controllers: $(48n - 4)$ millimetres or $(3.78n - 0.16)$ inches.

$\frac{1}{4}$ -DIN Controllers: $(96n - 4)$ millimetres or $(7.56n - 0.16)$ inches

The main dimensions of the Controllers are shown in Figure 1-2.

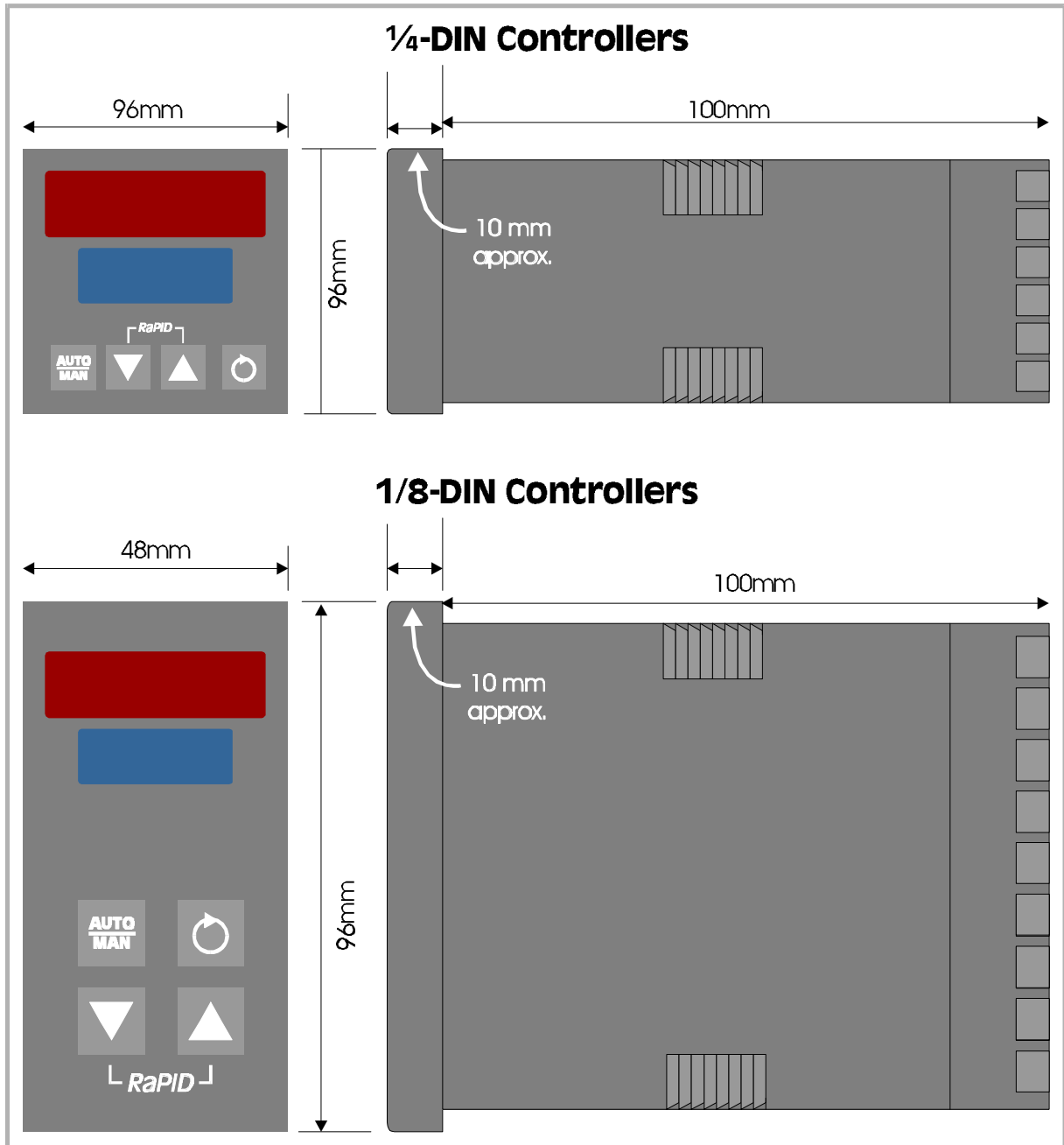

Figure 1-2 Main Dimensions

The procedure to panel-mount the Controller is shown in Figure 1-3.

CAUTION: Do not remove the panel gasket, as this may result in inadequate clamping of the instrument in the panel.

NOTE: The mounting clamp tongues may engage in the ratchets either on the sides of the Controller housing or on the top/bottom faces of the Controller housing. Therefore, when installing several Controllers side-by-side in one cutout, use the ratchets on the top/bottom faces.

Once the Controller is installed in its mounting panel, it may be subsequently removed from its housing, if necessary, as described in Subsection 2.1.

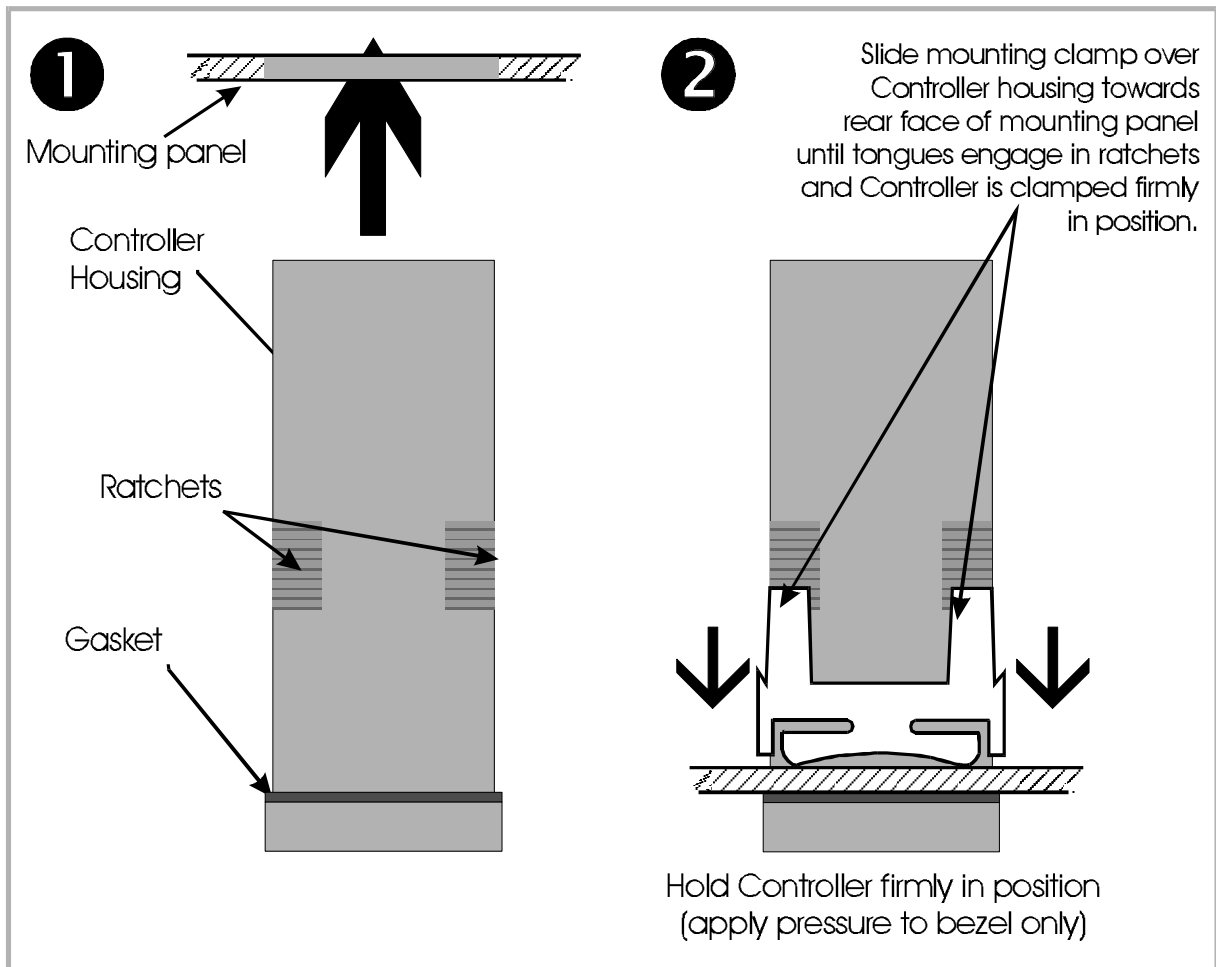

Figure 1-3 Panel-mounting the Controller

1.3 CONNECTIONS AND WIRING

The rear terminal connections are illustrated in Figure 1-4.

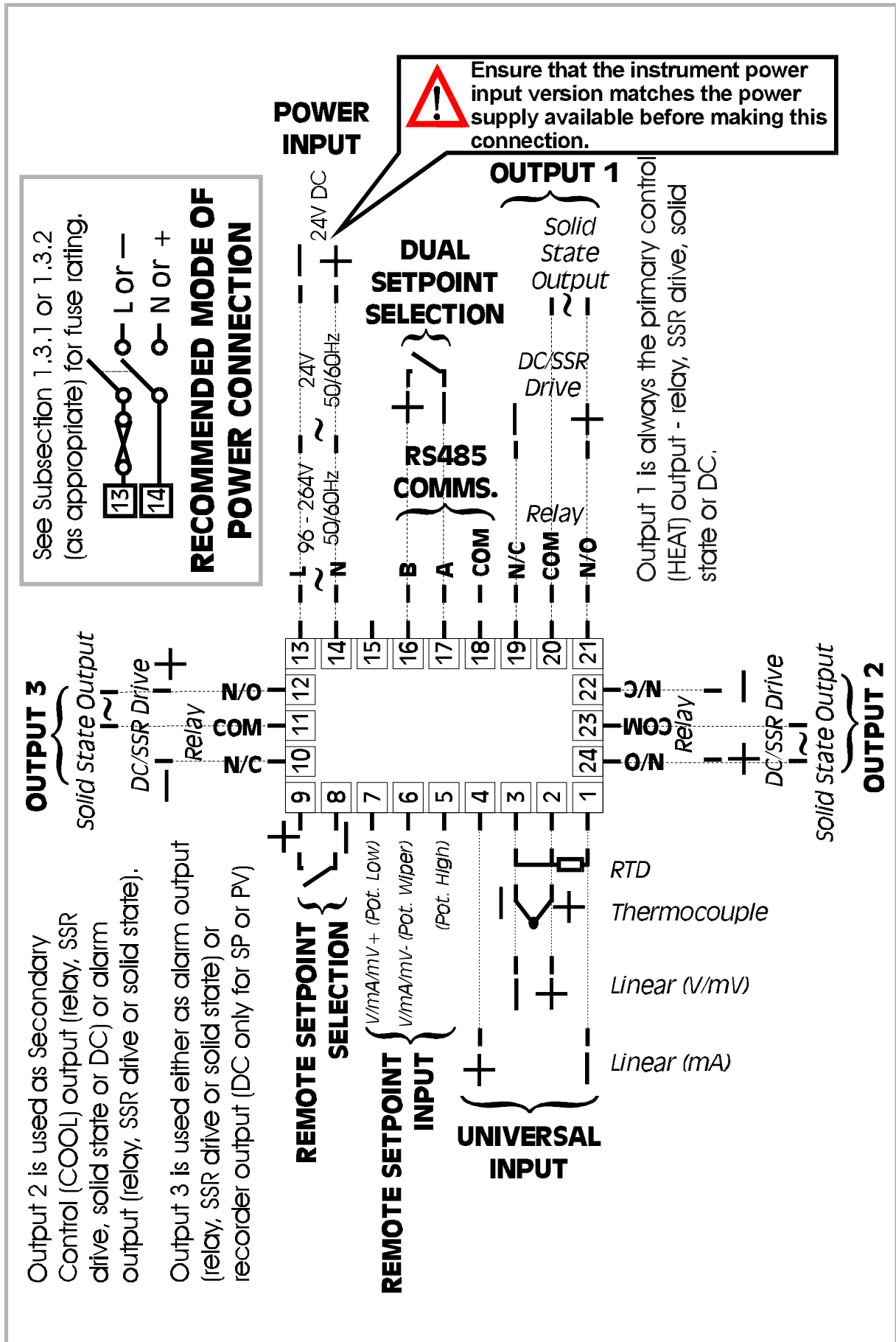

Figure 1-4 Rear Terminal Connections

1.3.1 Mains (Line) Input

The Controller will operate on 96 - 264V AC 50/60Hz mains (line) supply. The power consumption is approximately 4 VA.

CAUTION: This equipment is designed for installation in an enclosure which provides adequate protection against electric shock. Local regulations regarding electrical installation should be rigidly observed. Consideration should be given to prevention of access to the power terminations by unauthorised personnel. Power should be connected via a two-pole isolating switch (preferably situated near the equipment) and a 1A fuse, as shown in Figure 1-4. If the Controller has relay outputs in which the contacts are to carry mains (line) voltage, it is recommended that the relay contact mains (line) supply should be switched and fused in a similar manner but should be separate from the Controller mains (line) supply.

1.3.2 24V (Nominal) AC/DC Supply

The supply connections for the 24V AC/DC version of the Controller are shown in Figure 1-4. Power should be connected via a two-pole isolating switch and a 315mA slow-blow fuse (anti-surge Type T). The nominal 24V supply may be in the following ranges:

24V (nominal) AC 50/60Hz -	20 - 50V
24V (nominal) DC -	22 - 65V

1.3.3 Thermocouple Input

The correct type of thermocouple extension leadwire or compensating cable must be used for the entire distance between the Controller and the thermocouple, ensuring that the correct polarity is observed throughout. Joints in the cable should be avoided, if possible. The Controller's CJC facility must be enabled (normal conditions) for this input (see Subsection 3.3).

NOTE: Do not run thermocouple cables adjacent to power-carrying conductors. If the wiring is run in a conduit, use a separate conduit for the thermocouple wiring. If the thermocouple is grounded, this must be done at one point only. If the thermocouple extension lead is shielded, the shield must be grounded at one point only.

1.3.4 RTD Inputs

The compensating lead should be connected to Terminal 3. For two-wire RTD inputs, Terminals 2 and 3 should be linked. The extension leads should be of copper and the resistance of the wires connecting the resistance element should not exceed 5 ohms per lead (the leads should be of equal length).

1.3.5 Linear Inputs

For linear mA input ranges, connection is made to Terminals 1 and 4 in the polarity shown in Figure 1-4. For linear mV and V ranges, connection is made to Terminals 2 and 3 in the polarity shown in Figure 1-4. For details of the linear input ranges available, refer to Appendix A.

1.3.6 Dual Setpoint Selection

With the Dual Setpoint option fitted, Terminals 16 and 17 are used for external selection of the active setpoint. These terminals may be connected to (a) the voltage-free contacts of a switch or relay, or (b) a TTL-compatible voltage. Setpoint selection is as follows:

Voltage-Free:	Contacts open - Setpoint 1 selected Contacts closed - Setpoint 2 selected
TTL-compatible:	>2.0V - Setpoint 1 selected <0.8V - Setpoint 2 selected

NOTE: The Dual Setpoint option and the RS485 Serial Communications option are mutually exclusive.

1.3.7 Remote Setpoint Selection Input

With the Remote Setpoint option fitted, Terminals 8 and 9 are used for external selection of either the remote setpoint or the local setpoint. These terminals may be connected to (a) the voltage-free contacts of a switch or relay, or (b) a TTL-compatible voltage. Setpoint selection is as follows:

Voltage-Free:	Contacts open - Local setpoint selected Contacts closed - Remote setpoint selected
TTL-compatible:	>2.0V - Local setpoint selected <0.8V - Remote setpoint selected

With the Remote Setpoint option fitted and Dual Setpoint switching selected (see Subsection 3.2.3), Terminals 8 and 9 are used for external selection of Setpoint 1 or Setpoint 2:

Voltage-Free:	Contacts open - Setpoint 1 selected Contacts closed - Setpoint 2 selected
TTL-compatible:	>2.0V - Setpoint 1 selected <0.8V - Setpoint 2 selected

This enables a Controller to be equipped with the RS485 Serial Communications option *and* be capable of dual setpoint operation.

1.3.8 Remote Setpoint Input

With the Remote Setpoint option fitted, the secondary analogue input on Terminals 5, 6 and 7 is used as the remote setpoint input. The following input types are available:

0 - 20mA, 4 - 20mA,
0 - 5V, 1 - 5V, 0 - 10V, 2 - 10V,
0 - 50mV, 10 - 50mV, 0 - 100mV
Potentiometer (up to 2k Ω)

For further information, refer to Appendix A.

1.3.9 Relay Outputs

Refer to Figure 1-4. The contacts are rated at 2A resistive at 120/240V AC.

1.3.10 Solid State Outputs

These outputs provide up to 1A AC drive with a longer lifetime than an electromechanical relay. For further details, refer to Appendix A.

1.3.11 SSR Drive Outputs

Refer to Figure 1-4. These outputs produce a time-proportioned non-isolated DC signal (0 - 4.3V nominal, output impedance 250 ohms).

1.3.12 DC Outputs

See Figure 1-4 and Appendix A.

1.3.13 RS485 Serial Communications Link

The three-wire RS485 serial communications connections are on Terminals 16, 17 and 18, as shown in Figure 1-4. Where several Controllers are connected to one master port, the master port transceiver in the active state should be capable of driving a load of 12k Ω per Controller; the master port transceiver in the passive state must have pull-up/pull-down resistors of sufficiently low impedance to ensure that it remains in the quiescent state whilst supplying up to $\pm 100\mu\text{A}$ each to the Controller transceivers in the high impedance state. The cables used should be suitable for data transfer at the selected rate (1200, 2400, 4800 or 9600 Baud) over the required distance. Transmitters/receivers conform to the recommendations in the EIA Standard RS485.

NOTE: The RS485 Serial Communications option and the Dual Setpoint option are mutually exclusive.

2 INTERNAL LINKS AND SWITCHES

2.1 REMOVING THE CONTROLLER FROM ITS HOUSING



CAUTION: Before removing the Controller from its housing, ensure that all power has been removed from the rear terminals.

To withdraw the Controller from its housing, simply grip the side edges of the front panel (there is a finger grip on each edge) and pull the Controller forwards. This will release the Controller from its rear connectors in the housing and will give access to the Controller PCBs. Take note of the orientation of the Controller for subsequent replacement into the housing. The positions of the PCBs in the Controller are shown in Figure 2-1.

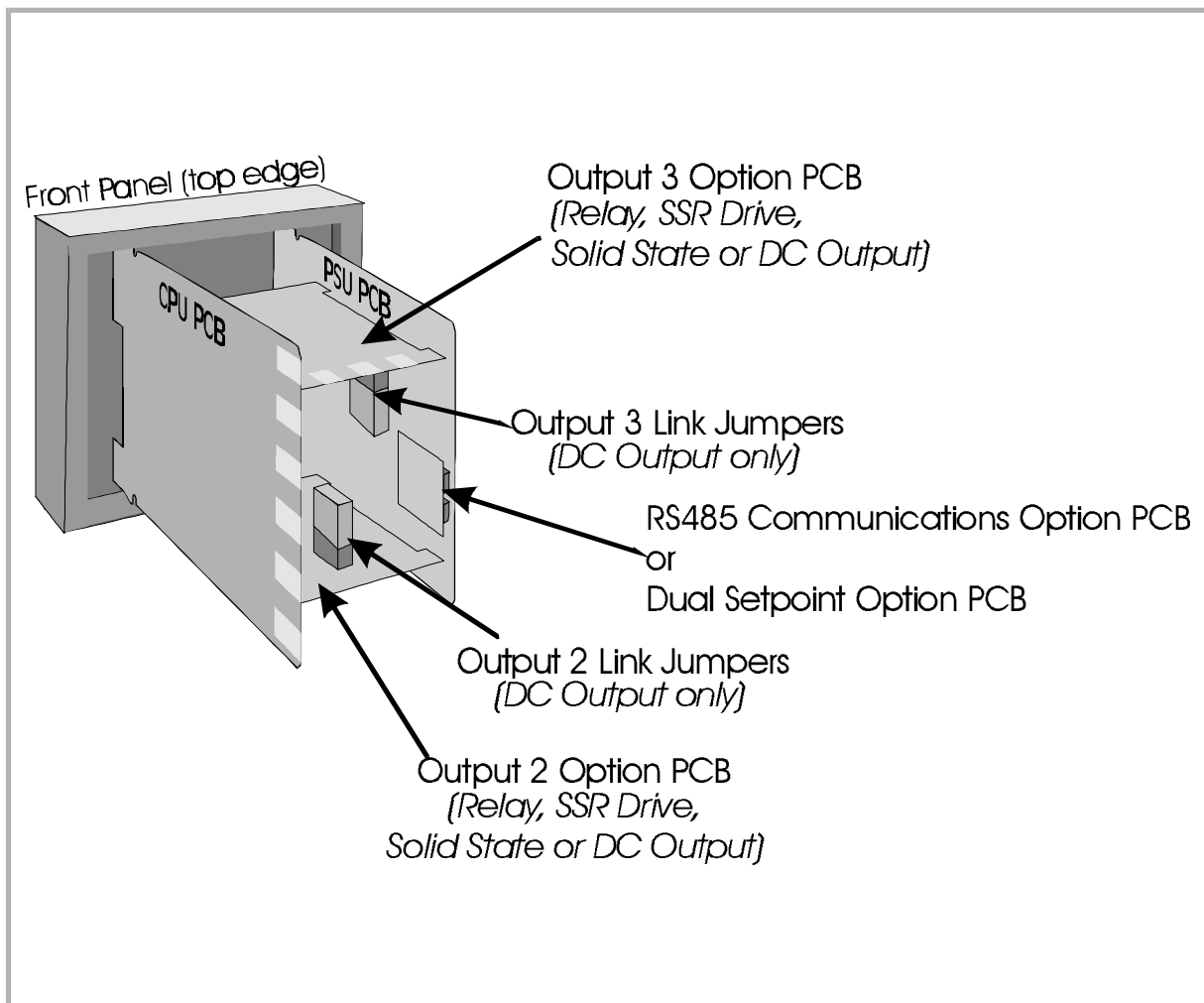

Figure 2-1 PCB Positions

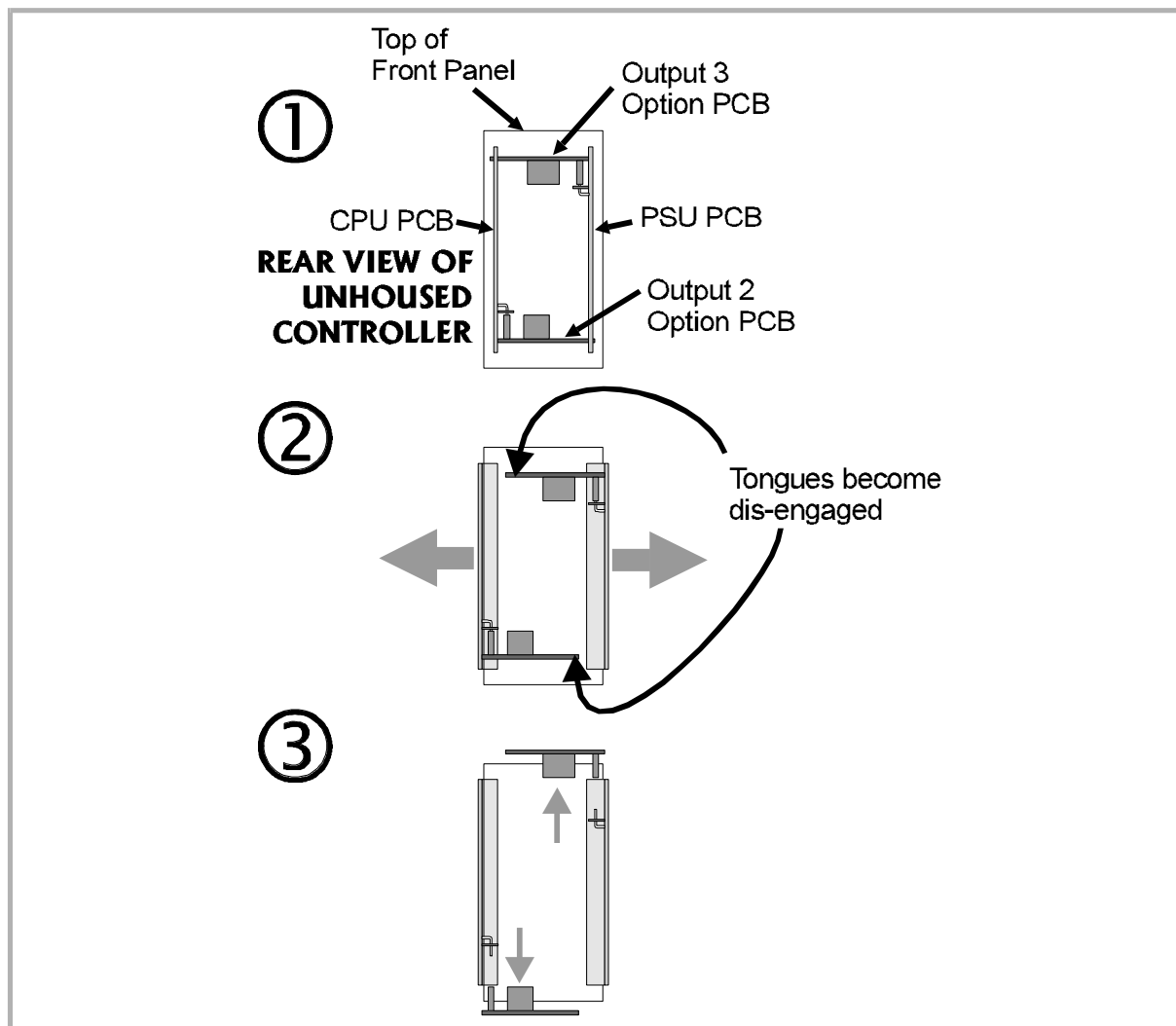

Figure 2-2 Removing the Output 2/Output 3 Option PCBs

2.2 REMOVING/REPLACING THE OUTPUT 2/OUTPUT 3 OPTION PCBs

With the Controller removed from its housing:

1. Push the rear ends of the CPU PCB and PSU PCB apart until the two tongues on each of the Output 2/Output 3 Option PCBs become dis-engaged - see Figure 2-2 Step 2. (The Output 2 Option PCB engages in holes in the PSU PCB and the Output 3 Option PCB engages in holes on the CPU PCB.

2. Pull the required Option PCB (Output 2 or Output 3) from its connector (Output 2 Option PCB is connected to the CPU PCB and Output 3 Option PCB is connected to the PSU PCB) - see Figure 2-2 Step 3. Note the orientation of the PCB in preparation for its replacement.

Adjustments may now be made to the link jumpers on the CPU PCB and the Output 2/Output 3 Option PCBs (if DC output). The replacement procedure is a simple reversal of the removal procedure.

2.3 REMOVING/REPLACING THE RS485 SERIAL COMMUNICATIONS OPTION PCB OR DUAL SETPOINT OPTION PCB

The RS485 Communications Option PCB or Dual Setpoint Option PCB is mounted on the inner surface of the PSU PCB and can be removed when the Controller is removed from its housing (see Subsection 2.1) by pulling the Option PCB towards the rear of the PSU PCB. Figure 2-3 illustrates the removal/replacement procedure. *It is not necessary to remove the Output 2/Output 3 Option PCBs to perform this procedure.*

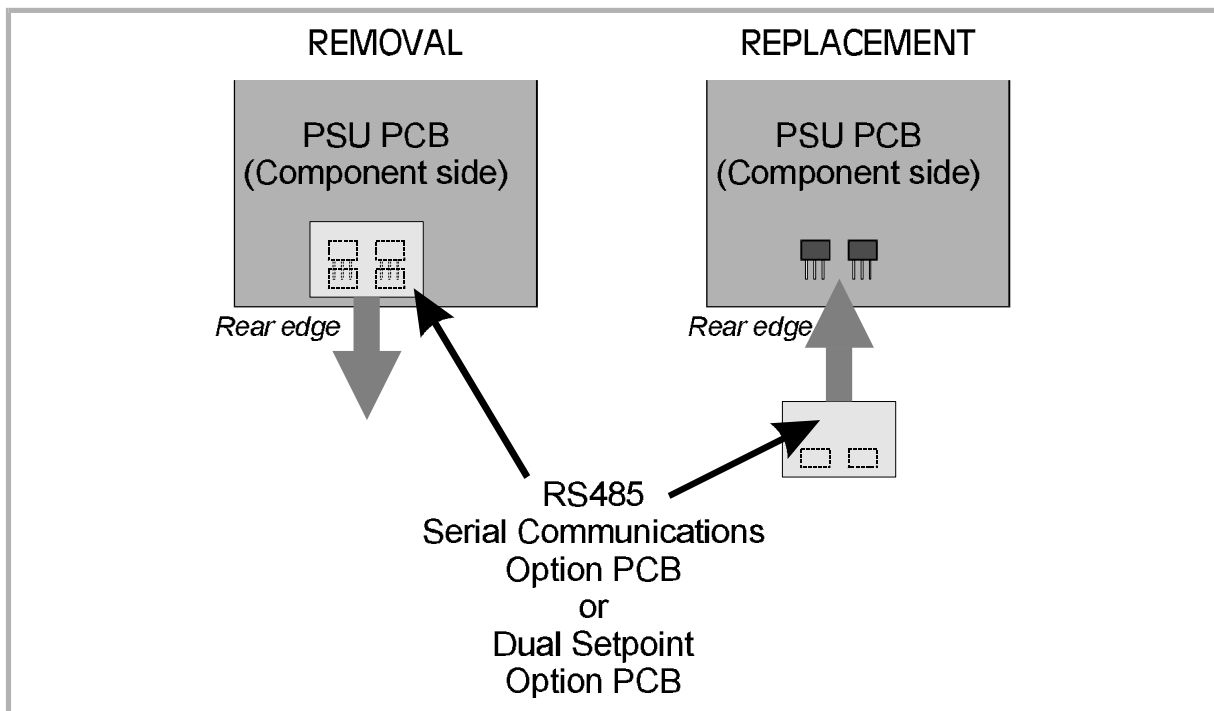

Figure 2-3 Removing/Replacing the RS485 Communications Option PCB or the Dual Setpoint Option PCB

2.4 REPLACING THE CONTROLLER IN ITS HOUSING

To replace the Controller, simply align the CPU PCB and PSU PCB with their guides and connectors in the housing and slowly but firmly push the Controller into position.

CAUTION: Ensure that the instrument is correctly orientated. A stop will operate if an attempt is made to insert the instrument upside-down. *This stop must not be over-ridden.*

2.5 SELECTION OF INPUT TYPE

The required input type is selected on link jumpers LJ1/LJ2/LJ3 on the CPU PCB (see Figure 2-4). Input Type selection is as shown on the right.

Input Type	Link Jumpers Fitted
RTD or DC (mV)	None (Parked)
Thermocouple	LJ3
DC (mA)	LJ2
DC (V)	LJ1

2.6 SECONDARY ANALOGUE INPUT TYPE SELECTION

If the Remote Setpoint option is fitted, Link Jumpers LJ10 and LJ11 on the CPU PCB are used to select the input type (see Figure 2-4). Selection is as shown on the right.

Input Type	Link Jumpers Fitted
Remote Setpoint, Linear DC (mV)	None (Parked)
Remote Setpoint, Linear DC (mA)	LJ10
Remote Setpoint, Linear DC (V)	LJ11
Remote Setpoint, Potentiometer	None (Parked)
Dual Setpoint Switching	None (Parked)

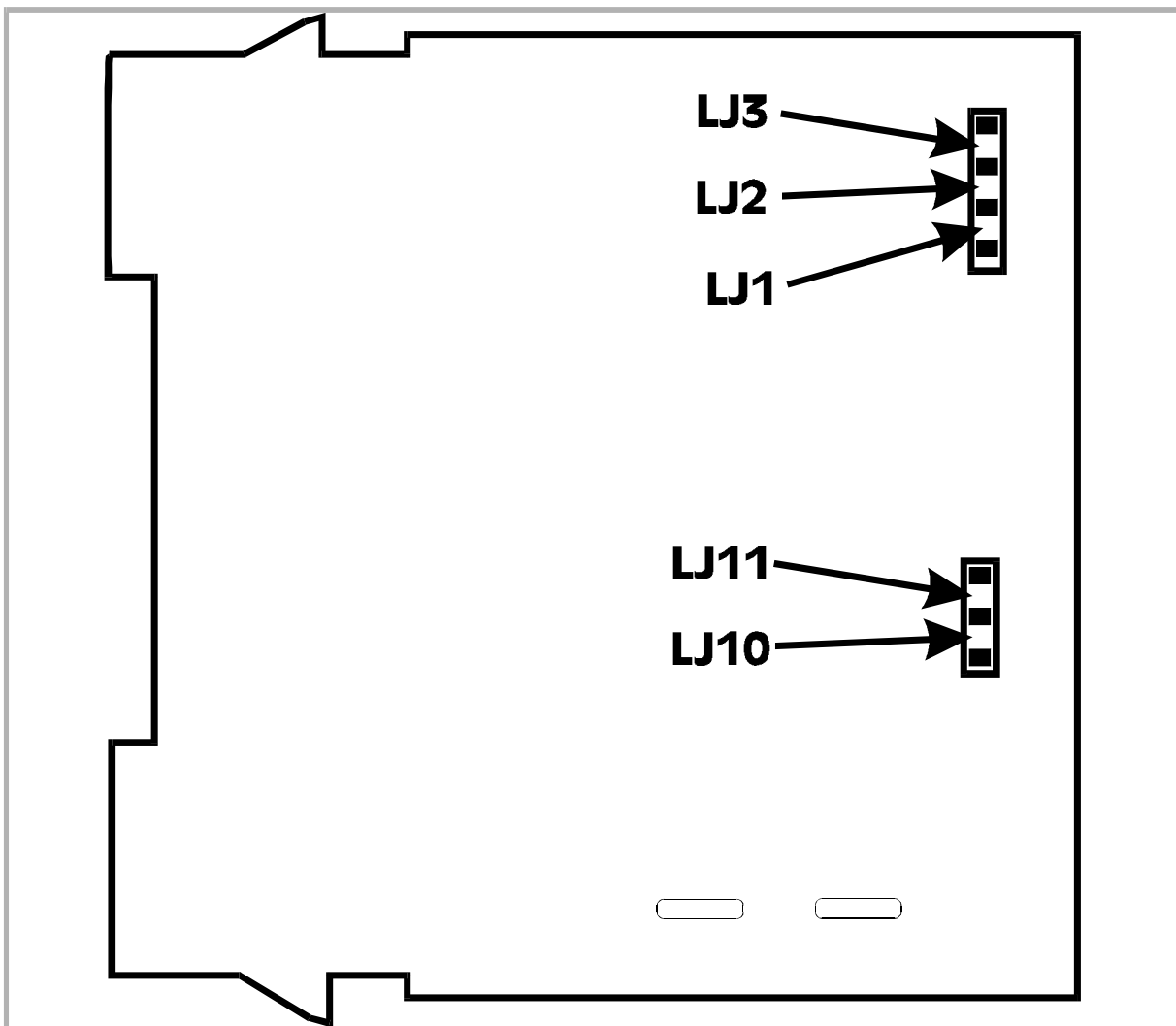

Figure 2-4 CPU PCB Link Jumpers

2.7 SELECTION OF PRIMARY OUTPUT (OUTPUT 1) TYPE

The required type of Output 1 is selected by Link Jumpers LJ4, LJ5, LJ6, LJ7, LJ8 and LJ9 on the PSU PCB (see Figure 2-5). Selection is as shown on the right.

Output 1 Type	Link Jumpers Fitted
Relay or Solid State	LJ5 & LJ6
SSR Drive	LJ4 & LJ7
DC (0 - 10V)	LJ8
DC (0 - 20mA)	LJ9
DC (0 - 5V)	LJ8
DC (4 - 20mA)	LJ9

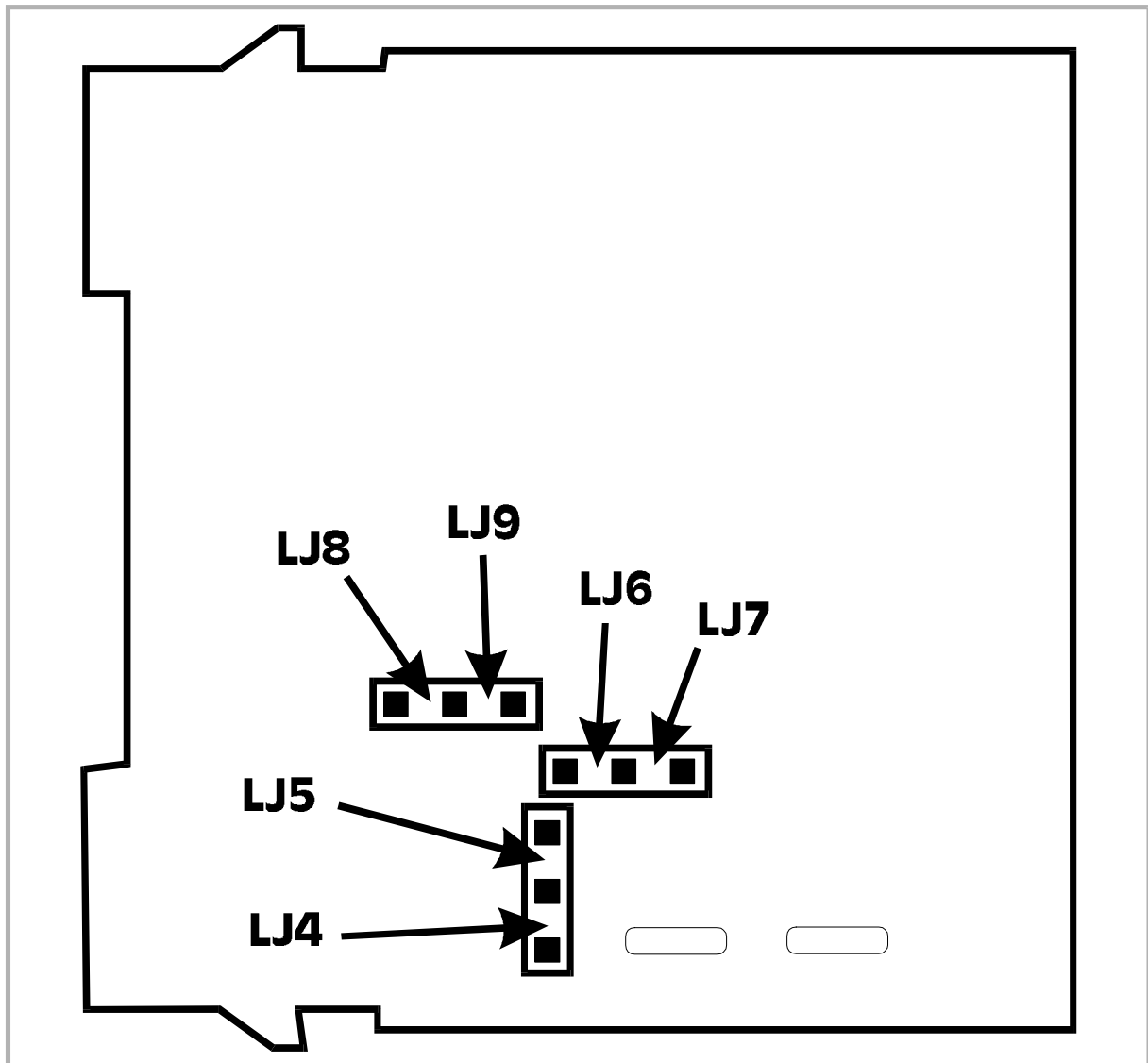

Figure 2-5 PSU PCB Link Jumpers

2.8 OUTPUT 2 TYPE/OUTPUT 3 TYPE

The type of output for Output 2 and Output 3 is determined by the Option PCB fitted in the appropriate position (see Figure 2-1) and, in the case of the DC Output Option PCB being fitted, the setting of Link Jumpers LJ8 and LJ9 on that Option PCB (see Figure 2-6 and table below). There are three types of option PCB which may be used for Output 2 and Output 3:

1. Relay Output Option PCB (no link jumpers)
2. SSR Output Option PCB (no link jumpers)
3. DC Output Option PCB (link jumpers as shown in Figure 2-6)

In the case of the DC Output Option PCB being fitted for Output 2 and/or Output 3, the DC output range is selected as shown on the right.

DC Output Range	Link Jumpers Fitted
DC (0 - 10V)	LJ8
DC (0 - 20mA)	LJ9
DC (0 - 5V)	LJ8
DC (4 - 20mA)	LJ9

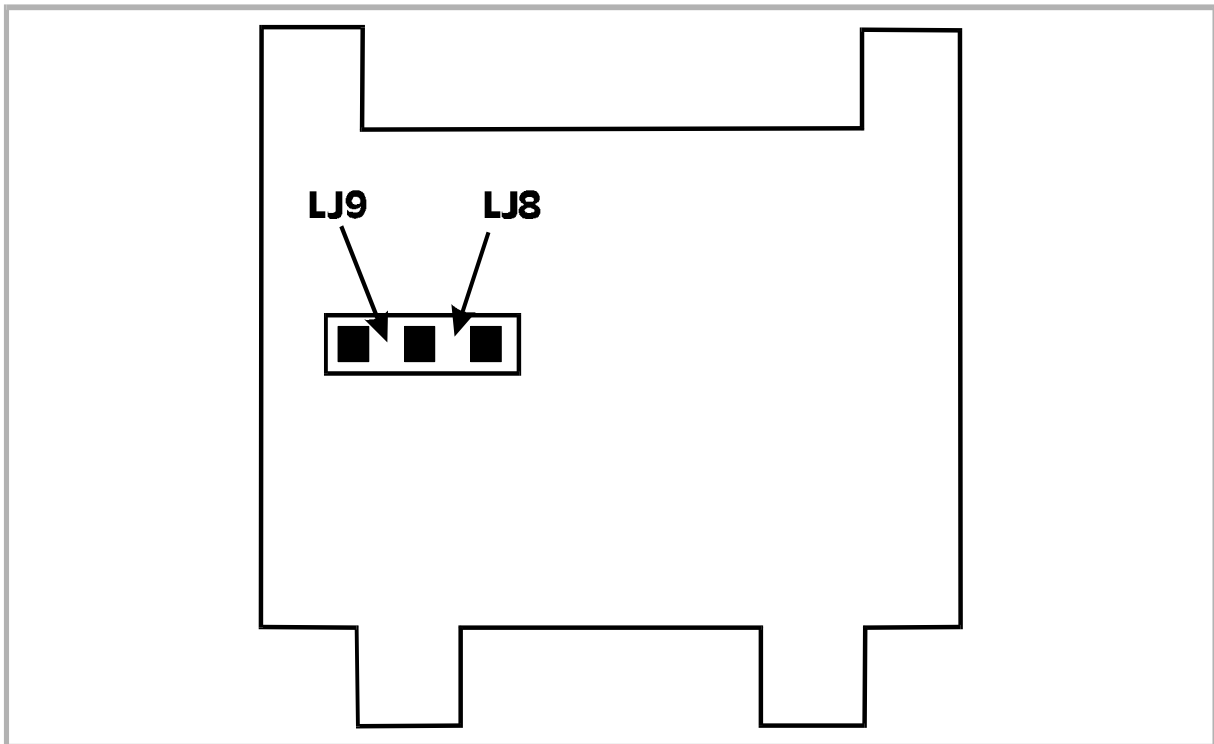

Figure 2-6 DC Output Option PCB - Link Jumpers

3 CONFIGURATION MODE

3.1 ENTRY INTO CONFIGURATION MODE

To enter Configuration Mode:

- 1 Power-up the Controller.

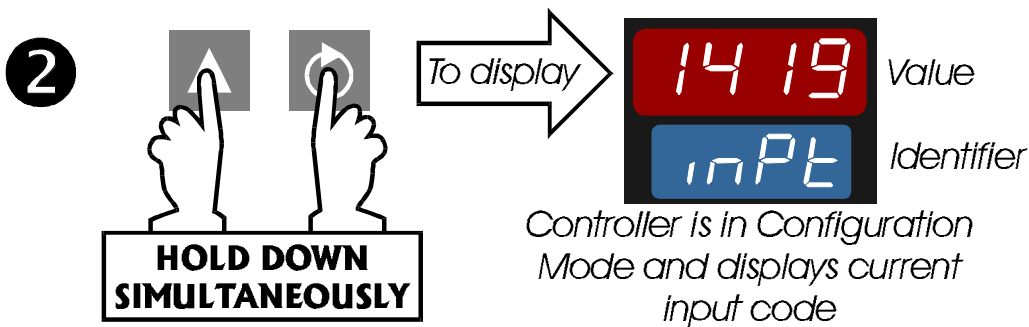
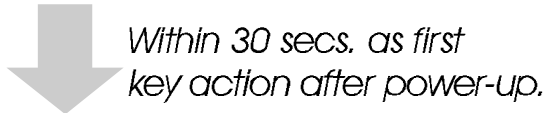

In Configuration Mode:

To select parameter



To change value (upper display flashes)

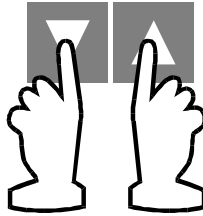

To confirm new value (upper display is static)



NOTES:

1. These must be the first key actions after power-up.
2. Changes to the setting of certain Configuration Mode parameters (e.g. input range, output use and type) will cause the Set Up Mode parameters to be automatically set to their default values (see also Volume 1, beginning of Section 2). It is recommended that *all* Configuration Mode parameters be finalised *before* the Set Up Mode parameters are adjusted to requirements.

3.2 HARDWARE DEFINITION CODE/OPTION SELECTION/SECOND INPUT USAGE

These parameters are special facilities in Configuration Mode, which are used to represent the hardware fitted (input type, Output 1 type, Output 2 type and Output 3 type etc.); these must be compatible with the hardware actually fitted.

3.2.1 Hardware Definition Code

The Hardware Definition Code can be accessed as follows:

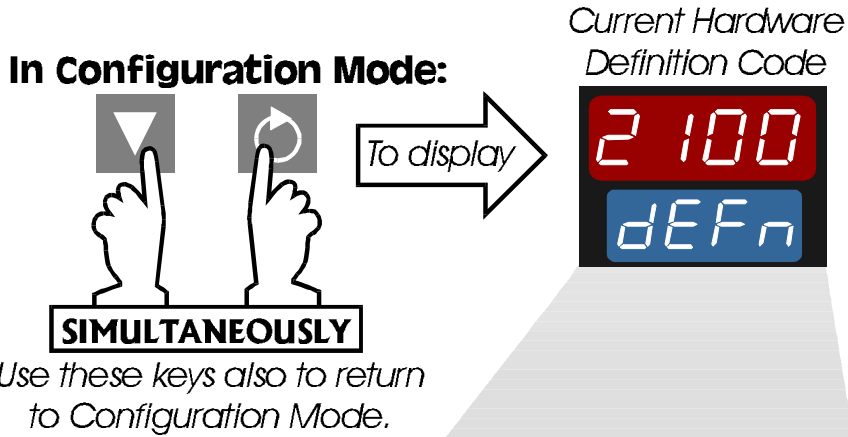

With Hardware Definition Code displayed:

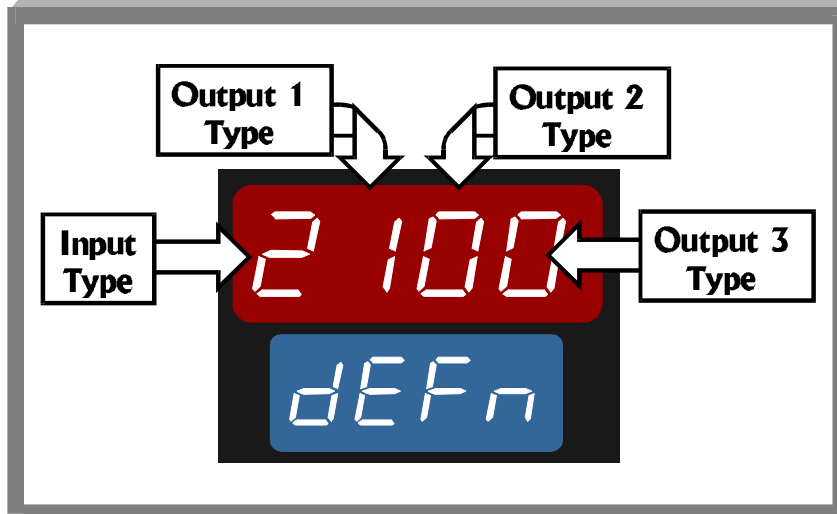
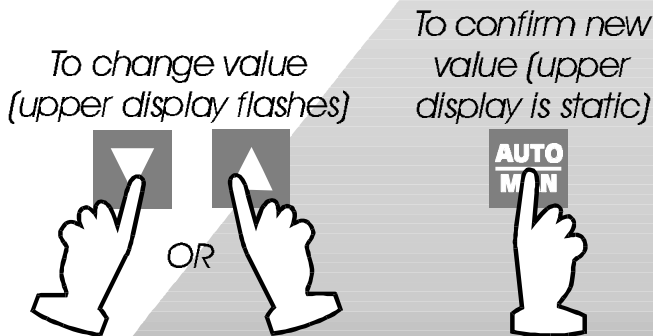

See also Table 3-1

Table 3-1 Hardware Definition Code - Input/Output Type Selection

Value	0	1	2	3	4	5	7
Primary Input		RTD/ Linear DC mV	Thermo-couple	Linear DC mA	Linear DC V		
Output 1		Relay	SSR Drive or Solid State	DC 0 - 10V	DC 0 - 20mA	DC 0 - 5V	DC 4 - 20mA
Output 2	Not fitted	Relay	SSR Drive or Solid State	DC 0 - 10V	DC 0 - 20mA	DC 0 - 5V	DC 4 - 20mA
Output 3	Not fitted	Relay	SSR Drive or Solid State	DC 0 - 10V	DC 0 - 20mA	DC 0 - 5V	DC 4 - 20mA

- NOTES:
1. If Output 2 is set to be a relay/SSR drive/solid state output, it may be a control output (COOL) or an alarm output; if it is set to be a DC output, it can only be a control output (COOL).
 2. If Output 3 is set to be a relay/SSR drive/solid state output, it can only be an alarm output; if it is set to be a DC output, it can only be a recorder (i.e. re-transmitted process variable or setpoint) output.
 3. It can be seen from the table above that the SSR Drive output and the Solid State output share the same Hardware Definition Code. However, these two output types do not have the same sales ordering code. SSR Drive Output = 2; Solid State Output = 8.

The maximum setting available for this code is 4777. For example, the code for a Controller with a thermocouple input, DC 4 - 20mA primary output (Output 1) and relay Output 3 would be 2701.

NOTE: It is essential that this code is changed promptly whenever there is a change to the Controller's hardware configuration (change of input/output type, alarm/recorder output added/removed etc.). The Controller software depends upon this code to ensure that the Controller operates correctly.

This code may be viewed as a Read Only display in Operator Mode (see Volume 1, Subsection 1.12).

3.2.2 Option Selection

Whilst the Hardware Definition Code is displayed, the Option Selection feature can be accessed as follows:

With Hardware Definition Code displayed:

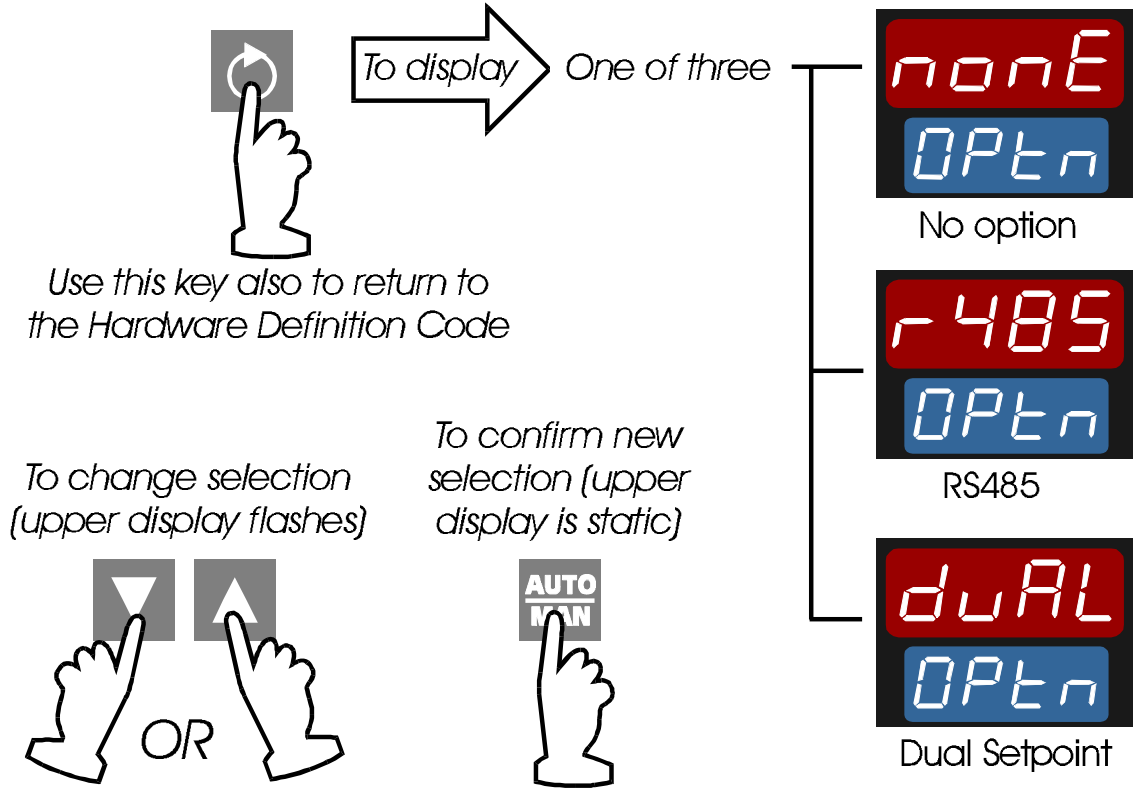

This indicates/selects the option fitted (if any). If the Dual Setpoint option or RS485 Serial Communications option is selected, the appropriate plug-in option board must be fitted.

NOTE: The RS485 Serial Communications option and the plug-in Dual Setpoint option board are mutually exclusive.

3.2.3 Second Input Usage

Whilst the Option Selection is displayed (if the Remote Setpoint Option hardware is fitted), selection of the usage for the second input (part of the Remote Setpoint Option) may be accessed as follows:

With Option Selection displayed:

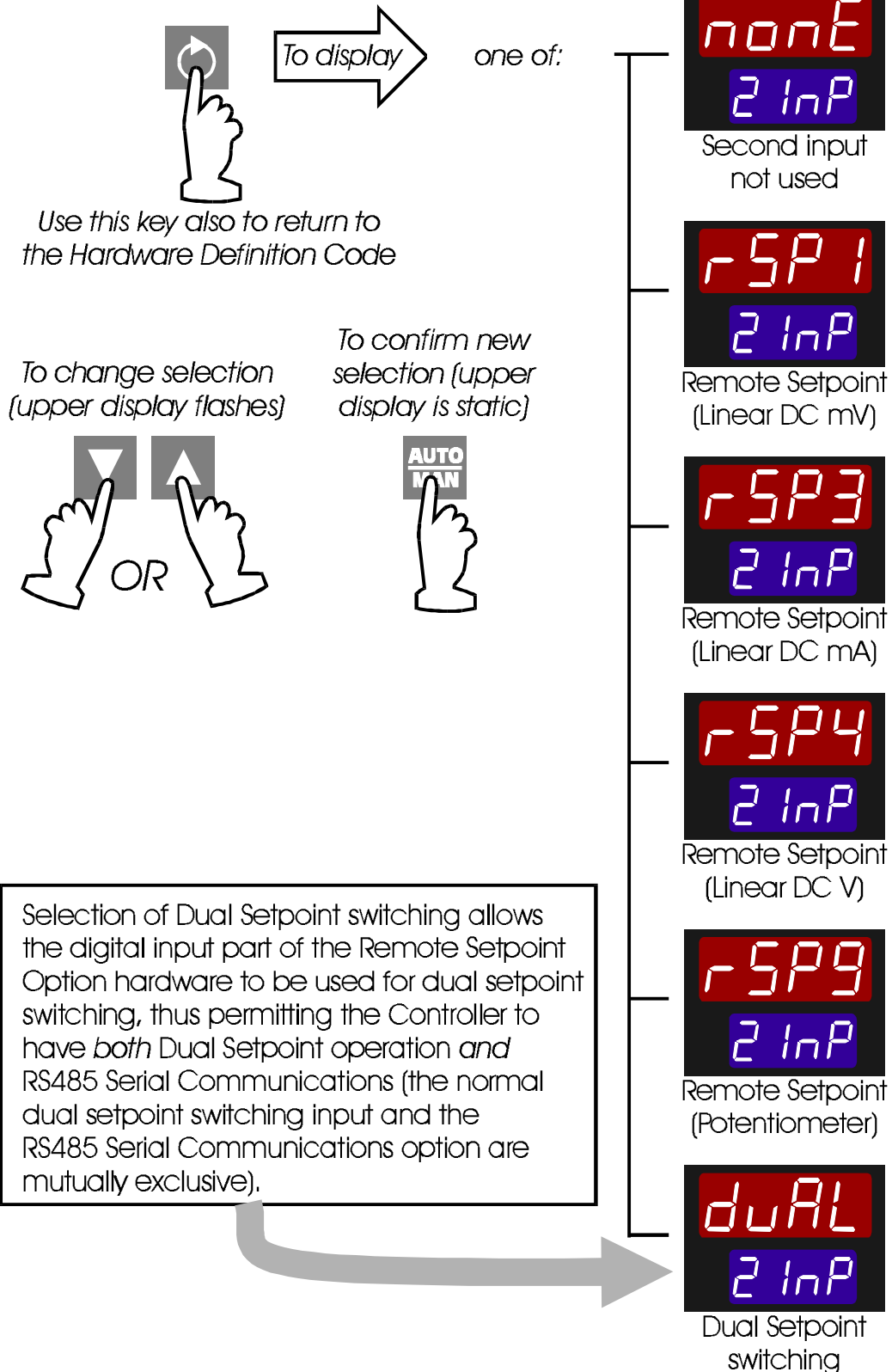

3.3 CONFIGURATION MODE PARAMETERS.

Parameter	Identifier	Description
Input Range	inPt	A four-digit code (see Appendix A). Default settings: Thermocouple - 1419 (Type J, 0 - 761°C) RTD/Linear mV - 7220 (RTD Pt100 0 - 800°C) Linear mA - 3414 (4 - 20mA) Linear V - 4446 (0 - 10V)
Remote Setpoint Input Range	r inP	A four-digit code dependent upon selected Second Input Usage (see Subsection 3.2.2): For rSP1 : 4443 (0 - 50mV) 4499 (10 - 50mV) 4412 (0 - 100mV) - Default For rSP3 : 3413 (0 - 20mA) 3414 (4 - 20mA) - Default) For rSP4 : 4445 (0 - 5V) 4434 (1 - 5V) 4446 (0 - 10V) - Default 4450 (2 - 10V) For rSP9 : Upper display shows Pot
Output 1 Action	Ctrl	rEv Reverse-acting dir Direct-acting
Alarm 1 Type	ALARM	P_hi Process High Alarm P_Lo Process Low Alarm dE Deviation Alarm bAnd Band Alarm nonE No alarm

Parameter	Identifier	Description
Alarm 2 Type	ALA2	P_h i Process High Alarm
		P_Lo Process Low Alarm (default)
		dE Deviation Alarm
		bAnd Band Alarm
		nonE No alarm
Alarm Inhibit	Inhi	nonE No alarms inhibited
		ALA1 Alarm 1 inhibited
		ALA2 Alarm 2 inhibited
		both Both Alarm 1 & Alarm 2 inhibited

Alarm Inhibit Feature

On power-up, an “alarm” condition may occur, based on the alarm value, the process variable value and, if appropriate to the alarm type, the (active) setpoint value. This would normally activate an alarm. However, if the pertinent alarm is inhibited, the alarm indication is suppressed and the alarm will remain inactive. This will prevail until the “alarm” condition returns to the “inactive” state, whereafter the alarm will operate in its normal fashion.

Also, during dual setpoint operation or remote/local setpoint operation, whenever there is switching from one setpoint to the other, similar alarm suppression will occur if the pertinent alarm is inhibited.

Parameter	Identifier	Description
Output 2 Usage	USE2	Out2 Output 2 secondary control (COOL) output
		A2_d Alarm 2 hardware output, direct-acting. Available only if relay/SSR drive/solid state output.
		A2_r Alarm 2 hardware output, reverse-acting. Available only if relay, SSR drive or solid state output.
		Or_d Direct-acting output for Logical OR of Alarm 1 and Alarm 2. Available only if relay, SSR drive, or solid state output.
		Or_r Reverse-acting output for Logical OR of Alarm 1 and Alarm 2. Available only if relay, SSR drive, or solid state output.
		Ad_d Direct-acting output for Logical AND of Alarm 1 and Alarm 2. Available only if relay, SSR drive, or solid state output.
		Ad_r Reverse-acting output for Logical AND of Alarm 1 and Alarm 2. Available only if relay, SSR drive, or solid state output.
		LP_d Loop Alarm output, direct-acting. Available only if relay, SSR drive or solid state output.
		LP_r Loop Alarm output, reverse-acting. Available only if relay, SSR drive or solid state output.
		Hy_d Alarm Hysteresis output, direct-acting. Available only if relay, SSR drive or solid state output.
	Hy_r Alarm Hysteresis output, reverse-acting. Available only if relay, SSR drive or solid state output.	

Example of Logical Combination of Alarms - Logical OR of Alarm 1 & Alarm 2

Direct-acting	Reverse-acting
AL1 OFF, AL2 OFF: Relay de-energised	AL1 OFF, AL2 OFF: Relay energised
AL1 ON, AL2 OFF: Relay energised	AL1 ON, AL2 OFF: Relay de-energised
AL1 OFF, AL2 ON: Relay energised	AL1 OFF, AL2 ON: Relay de-energised
AL1 ON, AL2 ON: Relay energised	AL1 ON, AL2 ON: Relay de-energised

Parameter	Identifier	Description
Output 3 Usage	USE3	Al_d Alarm 1 hardware output, direct-acting. Available only if relay/SSR drive/solid state output.
		Al_r Alarm 1 hardware output, reverse-acting. Available only if relay, SSR drive or solid state output.
		Or_d Direct-acting output for Logical OR of Alarm 1 and Alarm 2. Available only if relay, SSR drive, or solid state output.
		Or_r Reverse-acting output for Logical OR of Alarm 1 and Alarm 2. Available only if relay, SSR drive, or solid state output.
		Ad_d Direct-acting output for Logical AND of Alarm 1 and Alarm 2. Available only if relay, SSR drive, or solid state output.
		Ad_r Reverse-acting output for Logical AND of Alarm 1 and Alarm 2. Available only if relay, SSR drive, or solid state output.
		LP_d Loop Alarm output, direct-acting. Available only if relay, SSR drive or solid state output.
		LP_r Loop Alarm output, reverse-acting. Available only if relay, SSR drive or solid state output.
		Hy_d Alarm Hysteresis output, direct-acting. Available only if relay, SSR drive or solid state output.
		Hy_r Alarm Hysteresis output, reverse-acting. Available only if relay, SSR drive or solid state output.
		rEcS Recorder Output - Setpoint (DC output only)
		rEcP Recorder Output - Process Variable (DC Output only)

Example of Logical Combination of Alarms - Logical AND of Alarm 1 & Alarm 2

Direct-acting	Reverse-acting
AL1 OFF, AL2 OFF: Relay de-energised	AL1 OFF, AL2 OFF: Relay energised
AL1 ON, AL2 OFF: Relay de-energised	AL1 ON, AL2 OFF: Relay energised
AL1 OFF, AL2 ON: Relay de-energised	AL1 OFF, AL2 ON: Relay energised
AL1 ON, AL2 ON: Relay energised	AL1 ON, AL2 ON: Relay de-energised

Parameter	Identifier	Description
Comms. Baud Rate	bAud	Selectable: 1200, 2400, 4800, 9600 Baud
Comms. Address	Addr	Unique address assigned to the controller; in the range 1 - 32.
Cold Junction Compensation Enable/Disable*	CJC	EnAb Enabled (default)
		dISA Disabled
Lock Code	Loc	Read Only display of current four-digit Set Up Mode Lock Code.

* The Cold Junction Compensation Enable/Disable parameter appears in the parameter sequence only if the input selected (see Subsection 3.2.1) is Thermocouple. If Cold Junction Compensation is disabled, the initial lower display on entry into Operator Mode will momentarily show all horizontal LED elements lit:

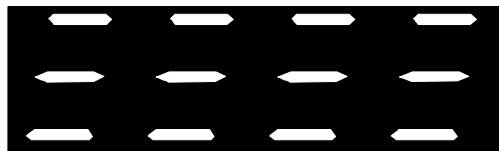

3.4 EXIT FROM CONFIGURATION MODE

To leave Configuration Mode press the Raise and Scroll keys simultaneously (see right).

NOTE: An automatic exit to Operator Mode will be made if, in Configuration Mode, there is no front panel key activity for two minutes.

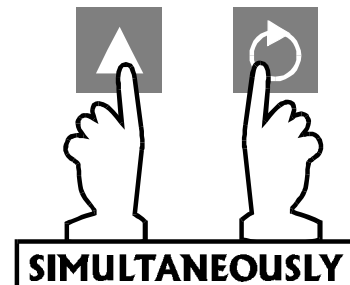

The exit is made via the power-up self-test routines which include a lamp test.

APPENDIX A PRODUCT SPECIFICATION

UNIVERSAL INPUT

General

Maximum per Controller:	One
Input Sample Rate:	Four samples/second
Digital Input Filter:	Time constant selectable from front panel - 0.0 (i.e. OFF), 0.5 to 100.0 seconds in 0.5-second increments.
Input Resolution:	14 bits approximately; always four times better than display resolution.
Input Impedance:	T/C, RTD and DC (mV): >100M Ω resistive DC (mA): >4.7 Ω resistive DC (V): >47k Ω resistive
Isolation:	Universal input isolated from all outputs except SSR at 240V AC.
Process Variable Offset:	Adjustable \pm input span.

Thermocouple: Ranges selectable from front panel:

Type	Input Range	Displayed Code	Type	Input Range	Displayed Code
R	0 - 1650 $^{\circ}$ C	1127	J	32 - 1401 $^{\circ}$ F	1420
R	32 - 3002 $^{\circ}$ F	1128	T	-200 - 262 $^{\circ}$ C	1525
S	0 - 1649 $^{\circ}$ C	1227	T	-328 - 503 $^{\circ}$ F	1526
S	32 - 3000 $^{\circ}$ F	1228	T	0.0 - 260.6 $^{\circ}$ C	1541
J	0.0 - 205.4 $^{\circ}$ C	1415	T	32.0 - 501.0 $^{\circ}$ F	1542
J	32.0 - 401.7 $^{\circ}$ F	1416	K	-200 - 760 $^{\circ}$ C	6726
J	0 - 450 $^{\circ}$ C	1417	K	-328 - 1399 $^{\circ}$ F	6727
J	32 - 842 $^{\circ}$ F	1418	K	-200 - 1373 $^{\circ}$ C	6709
J	0 - 761 $^{\circ}$ C *	1419	K	-328 - 2503 $^{\circ}$ F	6710

* Default setting

Continued overleaf⇒

Type	Input Range	Displayed Code	Type	Input Range	Displayed Code
L	0.0 - 205.7°C	1815	L	32 - 1403°F	1820
L	32.0 - 402.2°F	1816	B	211 - 3315°F	1934
L	0 - 450°C	1817	B	100 - 1824°C	1938
L	32 - 841°F	1818	N	0 - 1399°C	5371
L	0 - 762°C	1819	N	32 - 2550°F	5324

Calibration: Complies with BS4937, NBS125 and IEC584.

Sensor Break Protection: Break detected within two seconds. Control outputs set to OFF (0% power); Alarms operate as if the process variable has gone over-range.

Resistance Temperature Detector (RTD) and DC mV: Ranges selectable from front panel:

Input Range	Displayed Code	Input Range	Displayed Code
0 - 800°C *	7220	0.0 - 100.9°C	2295
32 - 1471°F	7221	32.0 - 213.6°F	2296
32 - 571°F	2229	-200 - 206°C	2297
-100.9 - 100.0°C	2230	-328 - 402°F	2298
-149.7 - 211.9°F	2231	-100.9 - 537.3°C	7222
0 - 300°C	2251	-149.7 - 999.1°F	7223

* Default setting

Type and Connection: Three-wire Pt100

Calibration: Complies with BS1904 and DIN43760.

Lead Compensation: Automatic scheme.

RTD Sensor Current: 200 μ A (approximately)

Sensor Break Protection: Break detected within two seconds. Control outputs set to OFF (0% power); Alarms operate as if the process variable has gone over-range.

DC Linear: Ranges Selectable from Front Panel:

Input Range	Displayed Code	Input Range	Displayed Code
0 - 20mA	3413	0 - 5V	4445
4 - 20mA *	3414	1 - 5V	4434
0 - 50mV	4443	0 - 10V *	4446
10 - 50mV	4499	2 - 10V	4450

* Default setting

(Changes may also be required to the CPU PCB link jumpers - see Subsection 2.4.1.)

Scale Range Maximum:	-1999 to 9999. Decimal point as required.
Scale Range Minimum:	-1999 to 9999. Decimal point as for Scale Range Maximum.
Minimum Span:	1 display LSD.
Sensor Break Protection:	Applicable to 4 - 20mA, 1 - 5V and 2 - 10V ranges only. Break detected within two seconds. Control outputs set to OFF (0% power); Alarms operate as if the process variable has gone under-range.

DUAL SETPOINT SELECTION INPUT (OPTION)

Type: Voltage-free, TTL-compatible

To select Setpoint 1

Maximum Contact Resistance (Closure):	50Ω
Maximum Voltage (TTL) for "0":	0.8V
Minimum Voltage (TTL) for "0":	-0.6V

To select Setpoint 2

Minimum Contact Resistance (Open):	5000Ω
------------------------------------	-------

Minimum Voltage (TTL) for "1":	2.0V
Maximum Voltage (TTL) for "1":	24.0V
Maximum Input Delay (OFF - ON):	1 second
Minimum input delay (ON - OFF):	1 second

REMOTE SETPOINT/POTENTIOMETER INPUT

Types available:	4 - 20mA, 0 - 20mA 0 - 10V, 2 - 10V, 0 - 5V, 1 - 5V 0 - 100mV, 0 - 50mV, 10 - 50mV Potentiometer (up to 2k Ω)
Measurement accuracy under reference conditions:	$\pm 0.25\%$ of input span ± 1 LSD
Input sample rate:	4/second
Input resolution:	13 bits
Isolation:	240V ac isolation from all other outputs and inputs except Remote Setpoint Select
Sensor Break protection:	For 4 - 20mA and 1 - 5V ranges only
Remote Setpoint Scale Max.:	-1999 to 9999; decimal point as for universal input.
Remote Setpoint Scale Min.:	-1999 to 9999; decimal point as for universal input.
Remote Setpoint Offset:	-1999 to 9999; decimal point as for universal input.

REMOTE SETPOINT SELECT INPUT

Type:	Voltage-free contact and TTL-compatible. Selects Local/Remote Setpoint (or Setpoint1/Setpoint 2, if Dual Setpoint operation selected).
-------	--

To Select Remote Setpoint/Setpoint 2

Maximum contact resistance (closure):	50Ω
Maximum voltage (TTL) for "0":	0.8V (1mA sink).
Minimum voltage for "0":	-0.6V

To Select Local Setpoint/Setpoint 1

Minimum contact resistance (open):	5000Ω
Minimum voltage (TTL) for "1":	2.0V.
Maximum voltage for "1":	24.0V
Maximum input delay (OFF-ON):	0.5 second
Minimum input delay (ON-OFF):	0.5 second
Isolation:	240V ac isolation from all outputs and inputs except Remote Setpoint

OUTPUT 1

General

Types Available:	Relay (as standard), SSR drive, solid state and DC as options.
------------------	--

Relay

Contact Type:	Single pole double throw (SPDT).
Rating:	2A resistive at 120/240V AC.
Lifetime:	>500,000 operations at rated voltage/current.
Isolation:	Inherent.

SSR Drive/TTL

Drive Capability:	SSR >4.3V DC into 250 Ω minimum.
Isolation:	Not isolated from input or other SSR outputs.

Solid State

Operating Voltage Range:	20 - 280Vrms (47 - 63Hz)
Current Rating:	0.01 - 1A (full cycle rms on-state @ 25°C); derates linearly above 40°C to 0.5A @ 80°C.
Max. Non-repetitive Surge Current (16.6ms):	25A peak
Min. OFF-State $\frac{dv}{dt}$ @ Rated Voltage:	500V/ μ s
Max. OFF-State leakage @ Rated Voltage:	1 mA rms
Max. ON-State Voltage Drop @ Rated Current:	1.5V peak.
Repetitive Peak OFF-state Voltage, Vdrm:	600V minimum.

DC

Resolution:	Eight bits in 250mS (10 bits in 1 second typical, >10 bits in >1 second typical).
Update Rate:	Every control algorithm execution.
Ranges:	0 - 20mA, 4 - 20mA, 0 - 5V, 0 - 10V

(Changes between V and mA ranges also require link jumper movement.)

Load Impedance:	0 - 20mA: 500 Ω maximum 4 - 20mA: 500 Ω maximum 0 - 10V: 500 Ω minimum 0 - 5V: 500 Ω minimum
Isolation:	Isolated from all other inputs and outputs.
Range Selection Method:	Link jumper and front panel code.

OUTPUT 2 (OPTION)

General

Types Available: Relay, SSR drive, solid state and DC.

Relay

Contact Type: Single pole double throw (SPDT).

Rating: 2A resistive at 120/240V AC.

Lifetime: >500,000 operations at rated voltage/current.

Isolation: Inherent.

SSR Drive/TTL

Drive Capability: SSR >4.3V DC into 250 Ω minimum.

Isolation: Not isolated from input or other SSR outputs.

Solid State

Operating Voltage Range: 20 - 280Vrms (47 - 63Hz)

Current Rating: 0.01 - 1A (full cycle rms on-state @ 25°C); derates linearly above 40°C to 0.5A @ 80°C.

Max. Non-repetitive Surge Current (16.6ms): 25A peak

Min. OFF-State $\frac{dv}{dt}$ @ Rated Voltage: 500V/ μ s

Max. OFF-State leakage @ Rated Voltage: 1mA rms

Max. ON-State Voltage Drop @ Rated Current: 1.5V peak.

Repetitive Peak OFF-state Voltage, V_{drm}: 600V minimum.

DC

Resolution:	Eight bits in 250mS (10 bits in 1 second typical, >10 bits in >1 second typical).
Update Rate:	Every control algorithm execution.
Ranges:	0 - 20mA, 4 - 20mA, 0 - 10V, 0 - 5V

(Changes between V and mA ranges also require link jumper movement.)

Load Impedance:	0 - 20mA: 500 Ω maximum 4 - 20mA: 500 Ω maximum 0 - 10V: 500 Ω minimum 0 - 5V: 500 Ω minimum
Isolation:	Isolated from all other inputs and outputs.
Range Selection Method:	Link jumper and front panel code.

OUTPUT 3 (OPTION)**General**

Types Available:	Relay and DC linear (Recorder Output only)
------------------	--

Relay

Contact Type:	Single pole double throw (SPDT).
Rating:	2A resistive at 120/240V AC.
Lifetime:	>500,000 operations at rated voltage/current.
Isolation:	Inherent.

DC

Resolution:	Eight bits in 250mS (10 bits in 1 second typical, >10 bits in >1 second typical).
Update Rate:	Every control algorithm execution.
Ranges:	0 - 20mA, 4 - 20mA, 0 - 10V, 0 - 5V

(Changes between V and mA require link jumper movement.)

Load Impedance:	
-----------------	--

0 - 20mA: 500 Ω maximum
 4 - 20mA: 500 Ω maximum
 0 - 10V: 500 Ω minimum
 0 - 5V: 500 Ω minimum

Isolation: Isolated from all other inputs and outputs.
 Range Selection Method: Link jumper and front panel code.

LOOP CONTROL

Control Types: **RaPID**, PID, PID/On-Off2, On-Off
 Automatic Tuning Types: Pre-Tune and Self-Tune.
 Proportional Bands: 0 (OFF), 0.5% - 999.9% of input span at 0.1% increments.
 Reset (Integral Time Constant): 1s - 99min 59s and OFF
 Rate (Derivative Time Constant): 0 (OFF) - 99 min 59 s.
 Manual Reset (Bias): Added each control algorithm execution. Adjustable in the range 0 - 100% of output power (single output) or -100% to +100% of output power (dual output).
 Deadband/Overlap: -20% to +20% of Proportional Band 1 + Proportional Band 2.
 ON/OFF Differential: 0.1% to 10.0% of input span.
 Auto/Manual Control: User-selectable with "bumpless" transfer into and out of Manual Control.
 Cycle Times: Selectable from $\frac{1}{4}$ s to 512 secs in binary steps.
 Setpoint Range: Limited by Setpoint Maximum and Setpoint Minimum.
 Setpoint Maximum: Limited by Setpoint and Range Maximum.
 Setpoint Minimum: Limited by Range Minimum and Setpoint.

Setpoint Ramp: Ramp rate selectable 1 - 9999 LSDs per hour and infinite. Number displayed is decimal-point-aligned with selected range.

ALARM CONTROL

Maximum Number of Alarms: Two "soft" alarms plus Loop Alarm

Max. No. of Outputs Available: Up to two outputs can be utilised for alarm purposes.

Combinatorial Alarms: Logical OR or AND of alarms to an individual hardware output is available.

COMMUNICATIONS

Type: Serial asynchronous UART-to-UART link.

Data Format: One start bit, parity bit, seven data bits, one stop bit.

Physical Layer: RS485

Presentation Layer: ASCII

Maximum Number of Zones: 32

Baud Rate: Front-panel-selectable from 9600, 4800, 2400 or 1200 Baud.

Zone Address Selection: Selectable from front panel in the range 1 - 32.

PERFORMANCE

Reference Conditions

Generally as BS5558.

Ambient Temperature: 20°C ±2°C

Relative Humidity: 60 - 70%

Supply Voltage: 90 - 264V AC 50Hz ±1%

Source Resistance: <10Ω for thermocouple input

Lead Resistance: $<0.1\Omega/\text{lead}$ balanced (Pt100)

Performance Under Reference Conditions

Common Mode Rejection: $>120\text{dB}$ at 50/60Hz giving negligible effect at up to 264V 50/60Hz.

Series Mode Rejection: $>500\%$ of span (at 50/60Hz) causes negligible effect.

DC Linear Inputs

Measurement Accuracy: $\pm 0.25\%$ of span $\pm 1\text{LSD}$.

Thermocouple Inputs

Measurement Accuracy: $\pm 0.25\%$ of span $\pm 1\text{LSD}$. NOTE: Reduced performance with Type "B" Thermocouple between 100 - 600°C (212 - 1112°F).

Linearisation Accuracy: Better than $\pm 0.2^\circ\text{C}$ any point, any 0.1°C range ($\pm 0.05^\circ\text{C}$ typical). Better than $\pm 0.5^\circ\text{C}$ any point, any 1°C range.

Cold Junction Compensation: Better than $\pm 0.7^\circ\text{C}$.

RTD Inputs

Measurement Accuracy: $\pm 0.25\%$ of span $\pm 1\text{LSD}$

Linearisation Accuracy: Better than $\pm 0.2^\circ\text{C}$ any point, any 0.1°C range ($\pm 0.05^\circ\text{C}$ typical). Better than $\pm 0.5^\circ\text{C}$ any point, any 1°C range.

DC Outputs - Accuracy

Output 1: $\pm 0.5\%$ (mA @ 250 Ω , V @ 2k Ω); 2% underdrive (4 - 20mA) and overdrive applies.

Output 2: $\pm 0.5\%$ (mA @ 250 Ω , V @ 2k Ω); 2% underdrive (4 - 20mA) and overdrive applies.

Output 3 (Recorder Output): $\pm 0.25\%$ (mA @ 250 Ω , V @ 2k Ω); Degrades linearly to $\pm 0.5\%$ for increasing burden (to specification limits).

Operating Conditions

Ambient Temp. (Operating):	0°C to 55°C
Ambient Temp. (Storage):	-20°C to 80°C
Relative Humidity:	20% - 95% non-condensing
Supply Voltage:	90 - 264V AC 50/60Hz (standard) 20 - 50V AC 50/60Hz or 22 - 65V DC (option)
Source Resistance:	1000Ω maximum (thermocouple)
Lead Resistance:	50Ω per lead maximum balanced (Pt100)

Performance Under Operating Conditions

Temperature Stability:	0.01% of span/°C change in ambient temperature.
Cold Junction Compensation (thermocouple Only):	Better than $\pm 1^\circ\text{C}$.
Supply Voltage Influence:	Negligible.
Relative Humidity Influence:	Negligible
Sensor Resistance Influence:	Thermocouple 100Ω: <0.1% of span error Thermocouple 1000Ω: <0.5% of span error RTD Pt100 50Ω/lead: <0.5% of span error
Radiated RF Field Influence:	Degradation of Output 1 accuracy to 3% at spot frequencies in the range 80 - 350MHz at field strength of 10V/m.

ENVIRONMENTAL

Operating Conditions:	See PERFORMANCE.
EMI Susceptibility:	Meets EN50082-2:1995
EMI Emissions:	Meets EN50081-2:1994 Part 2.
Safety Considerations:	Designed to comply with EN61010-1:1993 in as far as it is applicable.

Supply Voltage:	90 - 264V AC 50/60Hz (standard) 20 - 50V AC 50/60Hz or 22 - 65V DC (option)
Power Consumption:	4 watts approximately.
Front Panel Sealing:	To IP66 (NEMA 4).
Approvals:	Designed to meet UL and CSA approval.

PHYSICAL

Dimensions: Depth - 100mm approximately

Front Panel: Width - 96mm, Height - 96mm ($\frac{1}{4}$ -DIN)
Width - 48mm, Height - 96mm ($\frac{1}{8}$ -DIN)

Mounting: Plug-in with panel mounting fixing strap.
Panel cut-out size: 92mm x 92mm ($\frac{1}{4}$ -DIN)
45mm x 92mm ($\frac{1}{8}$ -DIN)

Terminals: Screw type (combination head) plus "telecom" type socket.

Weight: 0.48kg (1.06lb) maximum

APPENDIX B RaPID CONTROL FEATURE

RaPID (Response-assisted PID) offers dramatic improvements in control quality compared with conventional PID techniques. It responds more effectively than PID techniques to load conditions. With this feature, the Controller's response at start-up, during setpoint changes and during disturbances shows considerably reduced overshoot and much shorter settling times (see Figure B-1).

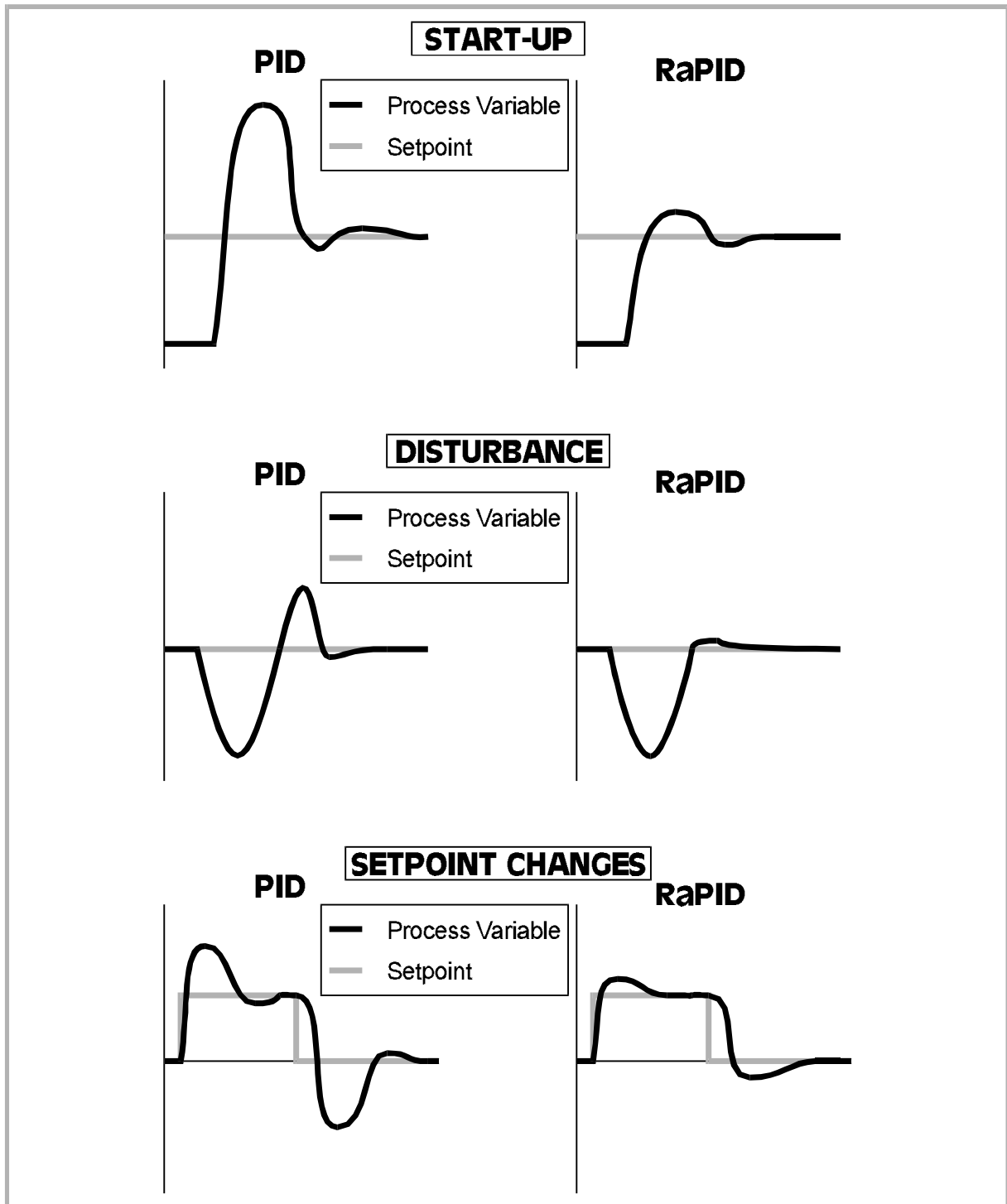

Figure B-1 Comparison of RaPID Control with Standard PID Control

RaPID works best with well-tuned PID terms. It is therefore recommended, on newly-installed Controllers, that the Pre-Tune facility (see Volume 1 Subsection 1.9) is run before **RaPID** is engaged.

NOTE: If Pre-Tune and **RaPID** are both engaged, Pre-Tune will run first. Once Pre-Tune (a single-shot process) is automatically dis-engaged, **RaPID** will operate automatically.

In conditions of frequent change in load characteristics, it is recommended that the Self-Tune facility (see Volume 1 Subsection 1.10) is used.

NOTE: With Self-Tune and **RaPID** engaged together, Self-Tune is suspended until **RaPID** is dis-engaged, whereupon Self-Tune will operate automatically.

The responses to **RaPID** being engaged are:

Pre-Tune	Self-Tune	Response	Indication
Not operational	Not selected	RaPID activated	AT static green
Not operational	Selected	Self-Tune suspended, RaPID activated	AT static green
Operational	Not selected	Pre-Tune completes operation, then RaPID activated	AT flashing green, then static green
Operational	Selected	Pre-Tune completes operation, then Self-Tune suspended and RaPID activated	AT flashing green, then static green

The responses to **RaPID** being dis-engaged are:

Pre-Tune	Self-Tune	Response	Indication
Not operational	Not selected	RaPID de-activated	AT OFF
Not operational	Selected	RaPID de-activated, Self-Tune comes out of suspension	AT static red
Operational	Not selected	Pre-Tune completes operation, then RaPID de-activated and return to standard PID control	AT flashing red, then OFF
Operational	Selected	Pre-Tune completes operation, then RaPID de-activated and Self-Tune comes out of suspension	AT flashing red, then static red

APPENDIX C ALARM HYSTERESIS OUTPUT

The Alarm Hysteresis option for Output 2 Usage and Output 3 Usage in Configuration Mode provides compatibility with the identical feature in some earlier controllers in this range.

An Alarm Hysteresis output is made active only when both alarms become active; it subsequently becomes inactive only when both alarms are inactive. Therefore, the status of an Alarm Hysteresis output when only one alarm is active depends upon the alarm status immediately prior to that alarm being activated; thus:

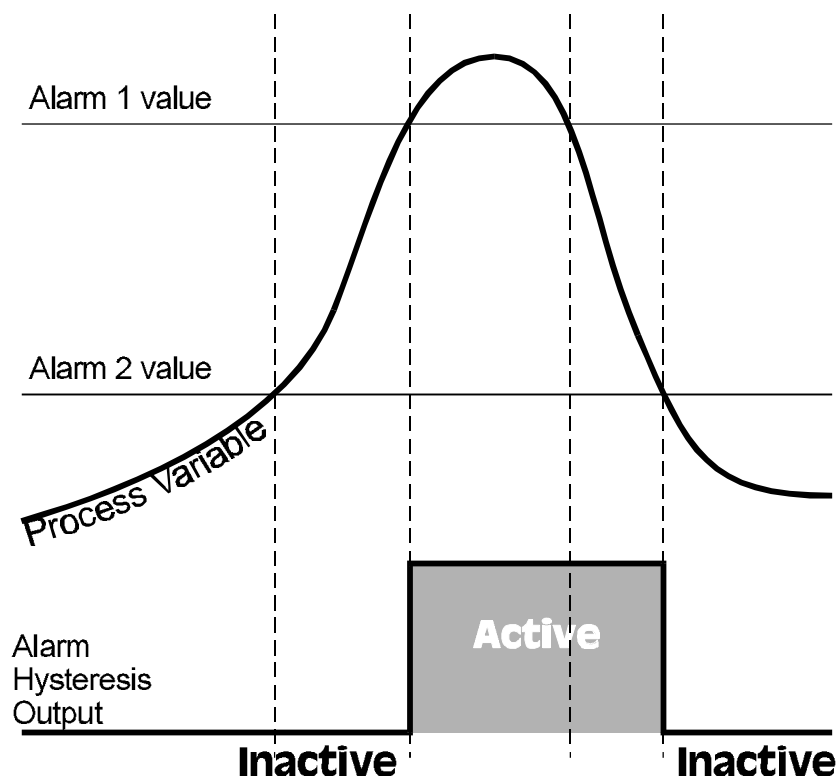

ALPHABETICAL INDEX

Page references are shown in the form x/y-z, where x is the Volume Number (I or II), y is the Section Number within that Volume and z is the Page Number within that Section. Thus, the reference to the second page of the third Section in Volume II would be II/3-2

A

AC/DC (24V) Supply	
Fuse rating	II/1-5
Rear terminal connections	II/1-5
Voltage ranges	II/1-5
Active Setpoint	
Front Panel key	
override	I/1-2 - 1-4
Indication of	
(Dual Setpoint operation)	I/1-2
Indication of	
(Remote Setpoint operation)	I/1-3
Alarm 1 (Band)	I/2-9
Alarm 1 (Deviation)	I/2-9
Alarm 1 (Process High)	I/2-9
Alarm 1 (Process Low)	I/2-9
Alarm 1 Hysteresis	I/2-9
Alarm 1 Value	
Band Alarm	I/2-3 - 2-4
Deviation Alarm	I/2-3 - 2-4
Process High Alarm	I/2-3 - 2-4
Process Low Alarm	I/2-3 - 2-4
Alarm 2 (Band)	I/2-12
Alarm 2 (Deviation)	I/2-12
Alarm 2 (Process High)	I/2-9
Alarm 2 (Process Low)	I/2-12
Alarm 2 Hysteresis	I/2-12
Alarm Operation	
Illustration of	I/2-10
Alarm Status	
Display of	I/1-5
Displaying (Set Up mode)	I/2-4
Auto Pre-Tune	
Enabling/disabling	I/2-14

B

Bias (Manual Reset)	I/2-7
---------------------	-------

C

Communications Line Release Time	
Maximum Value	I/3-1
Communications Message Format	I/3-2
Configuration Mode	
Automatic exit from	II/3-10
Entry into	II/3-1
Exit from	II/3-10
Controller Dimensions	II/A-13
CPU PCB	
Link Jumpers	II/2-4

D

DC Output	
Rear terminal connections	II/1-7
DC Output Option PCB	
Link jumpers	II/2-6
Deadband	I/2-5
Decimal Point Position	
Input scale range	I/2-4
Derivative Time Constant (Rate)	I/2-5
Digital Filter Time Constant	I/2-3
Displays (Operator Mode)	
Dual setpoint operation	I/1-2
Remote setpoint operation	I/1-3
Single setpoint operation	I/1-1
Dual Setpoint Option PCB	
Removal/replacement	II/2-3
Dual Setpoint Selection Input	
Rear terminal connections	II/1-6
TTL-compatible operation	II/1-6
Voltage-free operation	II/1-6

H

Hardware Definition Code	
Explanation of	I/1-9
Input/Output Type selection	II/3-3
Viewing	I/1-8
Hardware Option Selection	II/3-4
Hysteresis	I/2-3

I

Inactive Setpoint	
Indication of (Dual Setpoint operation)	I/1-2
Indication of (Remote Setpoint operation)	I/1-3
Input Filter Time Constant	I/2-2
Input Over-range Display	I/1-5
Input Scale Range	
Decimal point position	I/2-4
Input Scale Range Maximum	I/2-4
Input Scale Range Minimum	I/2-4
Input Type	
Selection of	II/2-4
Input Under-Range Display	I/1-5
Integral Time Constant (Reset)	
Adjustment of	I/2-5

L

Linear Input	
Rear terminal connections	II/1-6
Linear Input Scale Range	
Decimal point position	I/2-13
Maximum level	I/2-13
Minimum level	I/2-14
Lock Value	I/2-14
Loop Alarm	
Description	I/2-12
Enabling/disabling	I/2-12
Loop Alarm Time	I/2-13

M

Main Dimensions	II/1-2
Mains (Line) Input	
Fuse rating	II/1-5
Rear terminal connections	II/1-5
Voltage range	II/1-5
Manual Control	
Selecting/de-selecting	I/1-6
Manual Control Selection	
Enabling/disabling	I/2-14
Manual Reset (Bias)	I/2-7
Manual Tuning	
Output 1 and Output 2	I/2-16
Output 1 only	I/2-15

O

ON/OFF Differential	I/2-7
Output 1 Cycle Time	I/2-8
Output 1 Power	I/2-2
Output 1 Power Limit	I/2-8
Output 1 Type	
Selection of	II/2-5
Output 2 Cycle Time	I/2-8
Output 2 Option PCB	
Removal/replacement	II/2-2
Output 2 Power	I/2-5
Output 2 Type	
Selection of	II/2-6
Output 3 Option PCB	
Removal/replacement	II/2-2
Output 3 Type	
Selection of	II/2-6
Overlap	I/2-5

P

Panel-Mounting		
Cut-out dimensions (multiple installation)	II/1-1	
Cut-out dimension (single installation)	II/1-1	
Maximum panel thickness		II/1-1
Procedure	II/1-1	
Power Consumption	II/1-5	
Pre-Tune Facility		
Engaging/disengaging		I/1-6
Process Variable Offset		I/2-2
Proportional Band 1		I/2-5
Proportional Band 2		I/2-5
PSU PCB		
Link Jumpers	II/2-5	

R

RaPID and Pre-Tune Features		
Engaging simultaneously		I/1-8
RaPID Feature		
Dis-engaging	I/1-8	
Engaging	I/1-8	
Rate (Derivative Time Constant)		I/2-5
Rear Terminal Connections	II/1-3	
Recorder Output Scale Maximum		I/2-8
Recorder Output Scale Minimum		I/2-8
Relay Output		
Rear terminal connections		II/1-7
Relay contact rating	II/1-7	
Remote Setpoint Input		
Rear terminal connections		II/1-7
Types available	II/1-7	
Remote Setpoint Maximum Limit		I/2-7
Remote Setpoint Minimum Limit		I/2-7
Remote Setpoint Offset	I/2-7	
Remote Setpoint Selection Input		
Rear terminal connections		II/1-6
TTL-compatible operation		II/1-6
Voltage-free operation		II/1-6
Removing the Controller from its Housing	II/2-1	
Replacing the Controller in its Housing	II/2-3	
Reset (Integral Time Constant)		
Adjustment of	I/2-5	

RS485 Communications		
Enabling/disabling	I/2-14	
Master device transceiver requirement	II/1-7	
Rear terminal connections		II/1-7
RS485 Communications Option PCB		
Removal/replacement		II/2-3
RTD Input		
Maximum lead resistance		II/1-5
Rear terminal connections		II/1-5

S

Secondary Analogue Input Type		
Selection of	II/2-4	
Self-Tune Facility		
Engaging/dis-engaging		I/1-7
Sensor Break		
Effect on outputs (DC linear inputs)		II/A-3
Effect on outputs (RTD inputs)	II/A-2	
Effect on outputs (thermocouple inputs)		II/A-2
Indication of		I/1-5
Serial Communications		
Data Format	I/3-1	
Enabling/disabling		I/2-4
End of Message character		I/3-2
Error response	I/3-13	
Line turn-round time	I/3-1	
Message Types	I/3-2	
Protocol	I/3-2	
Scan Tables command		I/3-3
Start of Message character		I/3-2
Type 1 message	I/3-3	
Type 2 message	I/3-3	
Type 3 message	I/3-4	
Type 4 message	I/3-4	
Set Up Mode		
Automatic exit from	I/2-16	
Entry into	I/2-1	
Exit from	I/2-16	
Lock code	I/2-4	
Parameter adjustment		I/2-2
Parameter selection	I/2-2	
Set Up Parameters All at Default		
Indication of	I/2-1	
Setpoint		
Viewing/adjusting	I/1-4	
Setpoint Display Strategy (Operator Mode)		I/2-14

Setpoint High Limit	I/2-7	
Setpoint Low Limit	I/2-7	
Setpoint Ramp Rate		
Viewing/adjusting	I/1-4	
Setpoint Ramping		
Adjusting the ramping rate	I/1-4	
Enabling/disabling	I/2-14	
Switching on/off	I/1-4	
SSR Drive Output		
Rear terminal connections	II/1-7	

T

Thermocouple Input		
Rear terminal connections	II/1-5	

U

Unpacking Procedure	II/1-1	
---------------------	--------	--