



# $\frac{1}{4}$ -DIN & $\frac{1}{16}$ -DIN LIMIT CONTROLLERS

## Product Manual

59122-2

# PREFACE

This manual comprises two volumes:

- Volume I: This supports normal operation of the Limit Controllers. In normal operation, all actions taken by the user are in front of the Limit Controller panel.
- Volume II: This supports the installation, commissioning and configuring of the Limit Controllers. *It is intended for use only by personnel who are trained, equipped and authorised to carry out these functions.*



## **CAUTION: REFER TO MANUAL**

The international hazard symbol is inscribed adjacent to the rear connection terminals. It is important to read this manual before commissioning or installing the unit.

# 1/4-DIN & 1/16-DIN LIMIT CONTROLLERS PRODUCT MANUAL

## VOLUME I OPERATING INSTRUCTIONS

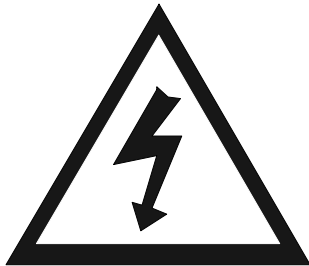

In normal operation, the operator must not remove the Limit Controller from its housing or have unrestricted access to the rear terminals, as this would provide potential contact with hazardous live parts.

Installation and configuration *must be undertaken by technically-competent servicing personnel*. This is covered in Volume II of this manual.

### Contents - Volume I

<b>1.</b>	<b>OPERATOR MODE</b>	<b>1-1</b>
1.1.	INTRODUCTION	1-1
1.2.	INITIAL DISPLAYS	1-1
1.3.	ALARM STATUS DISPLAY	1-1
1.4.	OVER-RANGE AND UNDER-RANGE DISPLAYS	1-2
1.5.	SENSOR BREAK INDICATION	1-2
1.6.	VIEWING THE HARDWARE DEFINITION CODE	1-2
1.7.	THE LIMIT CONDITION	1-3
1.8.	VIEWING THE HOLD VALUE & TIME EXCEEDED VALUE	1-3
1.9.	RESETTING THE HOLD VALUE OR TIME EXCEEDED VALUE	1-4
1.10.	ALARM CONDITION	1-4
<b>2</b>	<b>SET UP MODE</b>	<b>2-1</b>
2.1	ENTRY INTO SET UP MODE	2-1
2.2	SET UP MODE PARAMETERS	2-2

2.3	OPERATOR MODE DISPLAYS	2-7
2.4	EXIT FROM SET UP MODE	2-8
<b>3</b>	<b>RS485 SERIAL COMMUNICATIONS</b>	<b>3-1</b>
3.1	COMMUNICATIONS ENABLE/DISABLE	3-1
3.2	PHYSICAL REQUIREMENTS	3-1
3.3	INDIVIDUAL PARAMETERS	3-5
3.4	ERROR RESPONSE	3-9

# 1 OPERATOR MODE

## 1.1 INTRODUCTION

The Operator Mode is the normal day-to-day mode of the Limit Controller, once it has been set up and configured as required. The Controller front panel indicators and keys are shown in Figure 1-1.

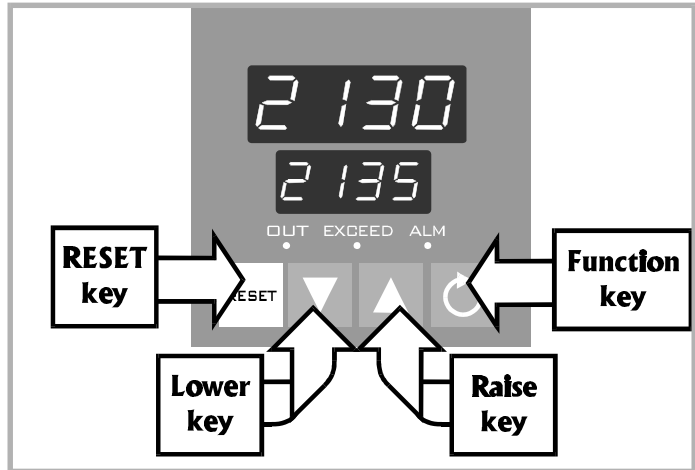

Figure 1-1 Keys and Indicators

## 1.2 INITIAL DISPLAYS

After the Controller's power-up self-test (during which, if the Function key is held down during power-up, the current Controller firmware revision is displayed), the initial Operator Mode displays appear (see Figure 1-2).

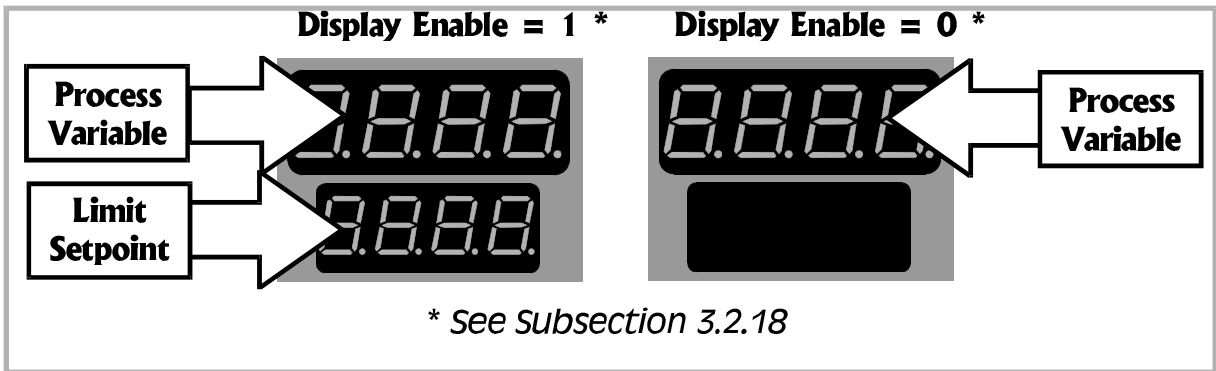

Figure 1-2 Initial Displays

## 1.3 ALARM STATUS DISPLAY

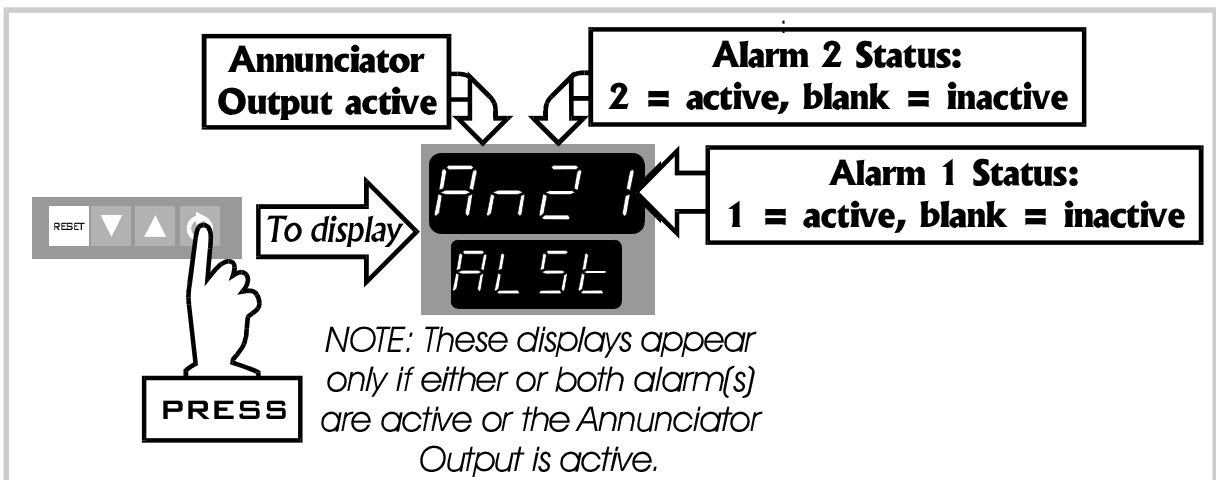

Figure 1-3 Alarm Status Display

### 1.4 OVER-RANGE AND UNDER-RANGE DISPLAYS

If the process variable attains a value higher than the input scale maximum limit (over-range) or lower than the input scale minimum limit (under-range), the upper display will show the appropriate one of the displays shown in Figure 1-4.

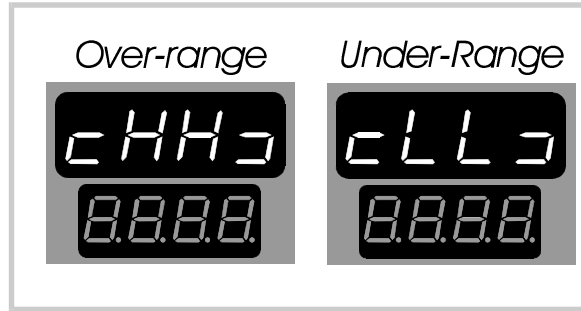

Figure 1-4 Over-range and Under-range Displays

### 1.5 SENSOR BREAK INDICATION

If a break is detected in the sensor circuit, the upper display shows:



The reaction of the alarms to a break is dependent upon the input type.

### 1.6 VIEWING THE HARDWARE DEFINITION CODE

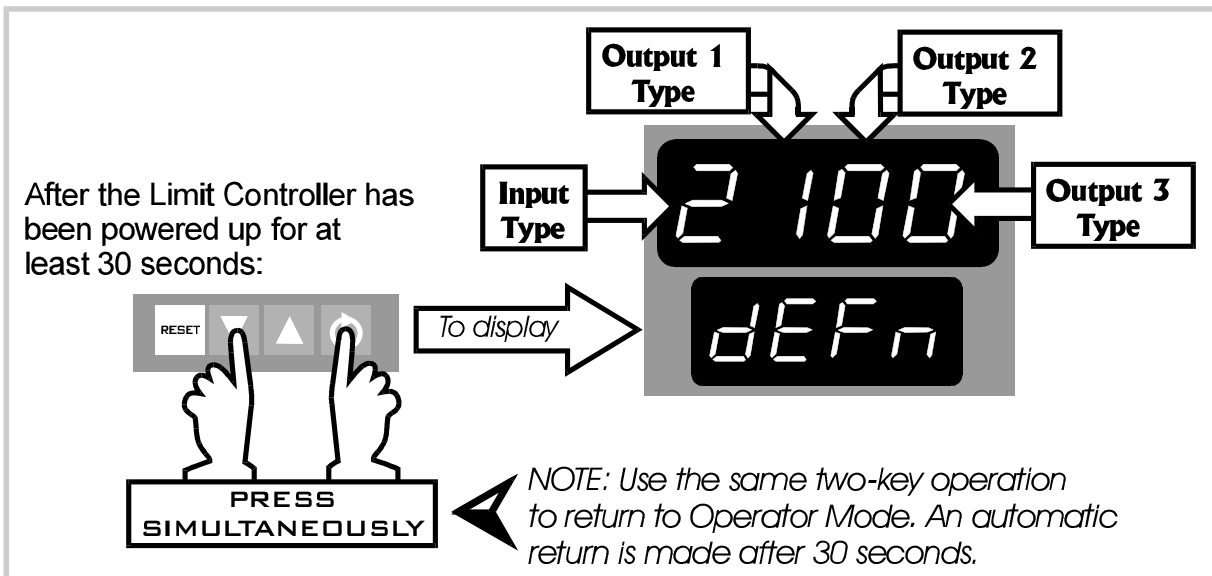

Figure 1-5 Viewing the Hardware Definition Code

The significance of the four characters in the code is as follows:

Value	0	1	2	3	4	5	7
Input		RTD/ Linear	T/couple	Linear (mA)	Linear (V)		
Output 1		Relay					
Output 2/3	Not fitted	Relay	SSR Drive	DC (0-10V)	DC (0-20mA)	DC (0-5V)	DC (4-20mA)

## 1.7 THE LIMIT CONDITION

When the process variable exceeds the limit setpoint (i.e.  $PV > SP$  for a High Limit or  $PV < SP$  for a Low Limit), the **EXCEED** and **OUT** indicators will come ON. If an annunciator output is selected and fitted, it will become active; the **ALM** LED will flash and the alarm status display will become available. If the operator then acknowledges the Limit Condition by pressing the **RESET** key, the annunciator output will be de-activated, the alarm condition will be removed and the **OUT** indicator will go OFF. When the process variable returns within the set limit, the **EXCEED** indicator will go OFF and the annunciator output will be de-activated (if it has not already been so by depression of the **RESET** key). The Limit Condition will remain ON until the **RESET** key is pressed, whilst the limit is not exceeded.

## 1.8 VIEWING THE HOLD VALUE & TIME EXCEEDED VALUE

The Limit Controller has a Hold Value facility whereby the maximum (for High Limit Action) or minimum (for Low Limit Action) process variable value since the Hold Value was last reset is retained. There is also a Time Exceeded Value which indicates the (accumulative) amount of time for which the limit has been exceeded since this parameter was last reset to zero. The Hold Value and Time Exceeded Value may be viewed as shown in Figure 1-6.

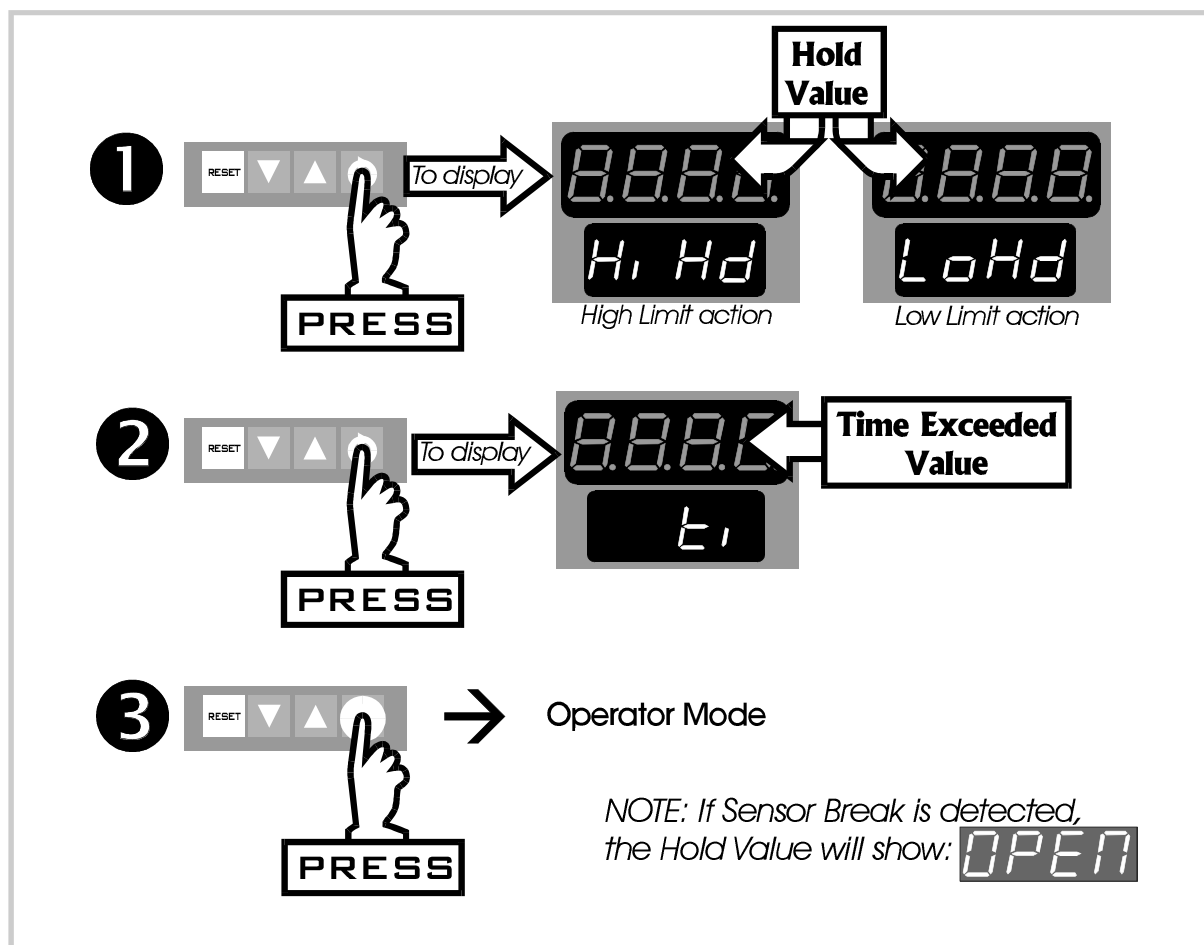

Figure 1-6 Viewing the Hold Value and Time Exceeded Value

The Time Exceeded value is in either of two formats:

- (a) mm:ss if the value is less than 100 minutes or
- (b) mmm:s (minutes and 10's seconds) if the value is 100 minutes or more.

If the value reaches 1000 minutes or more, the upper display shows: 

## 1.9 RESETTING THE HOLD VALUE OR TIME EXCEEDED VALUE

Select display of the Hold Value or the Time Exceeded value (as required) as described in Subsection 1.8. Then proceed as shown in Figure 1-7.

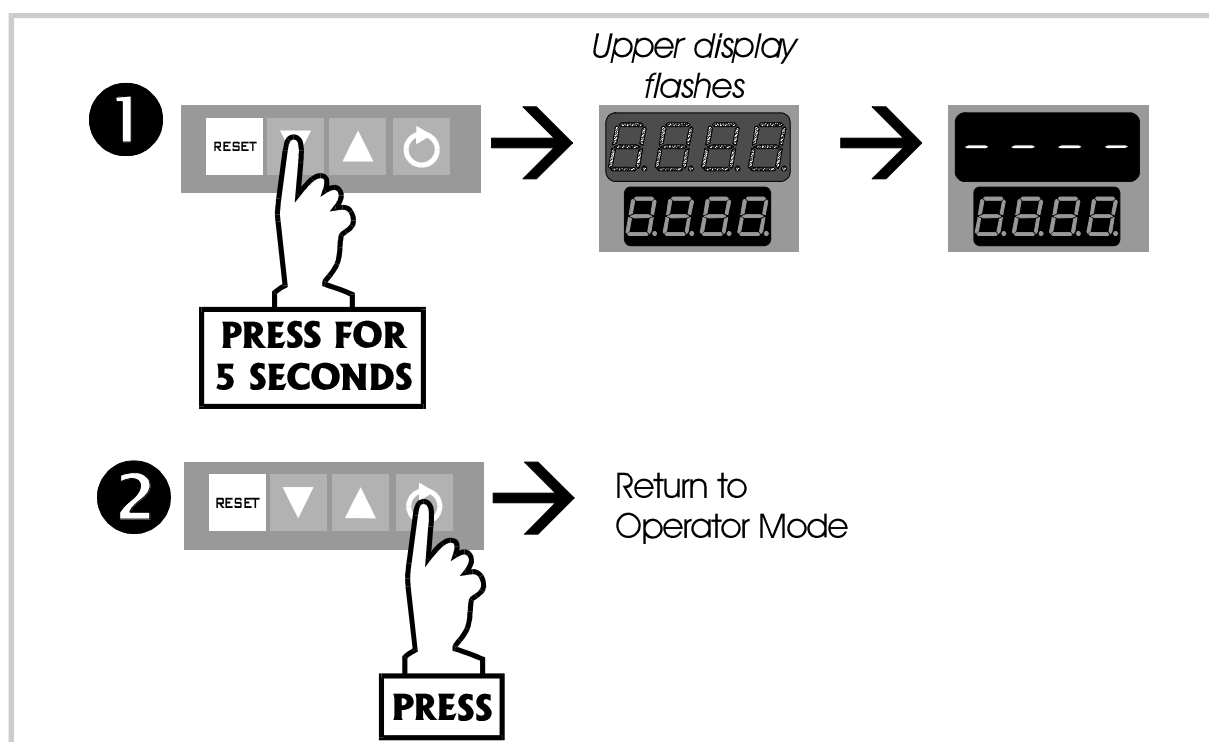

Figure 1-7 Resetting the Hold Value or Time Exceeded Value

If it is the Hold Value which is being reset, the Hold Value will almost instantly assume the current process variable value and will then operate in its normal manner.

## 1.10 ALARM CONDITION

Whenever either of the two internal "soft" alarms or an annunciator output becomes active, the **ALM** indicator will flash. Subsequent de-activation of the alarm (by the process variable value returning to within the alarm level) or acknowledgement of the annunciator output (by pressing the **RESET** key) will extinguish the **ALM** indicator.



## 2 SET UP MODE

NOTE: Adjustment to any Set Up Mode parameters should be performed only by personnel authorised to do so.

### 2.1 ENTRY INTO SET UP MODE

See Figure 2-1.

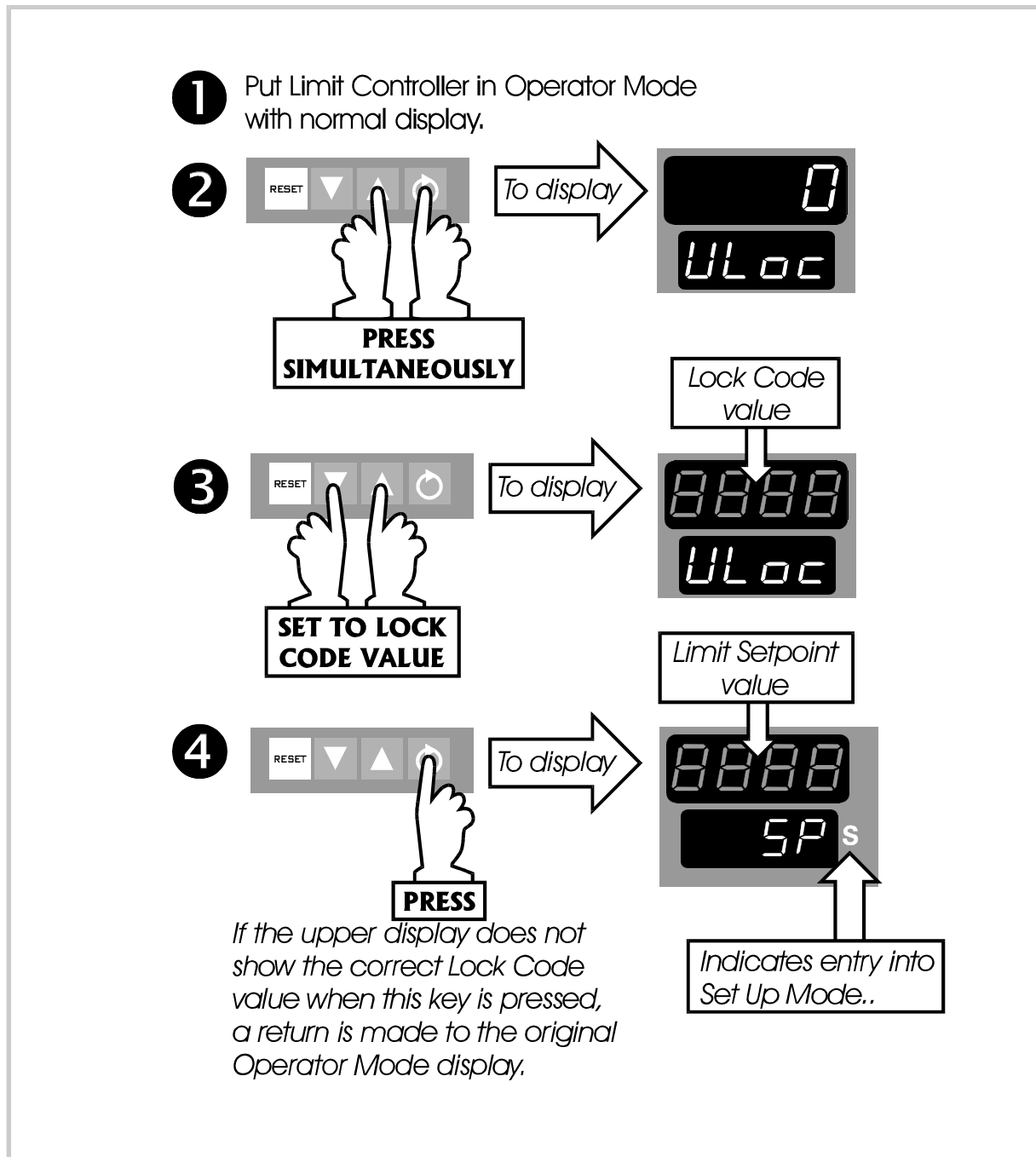
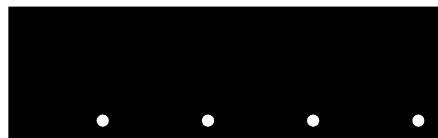

Figure 2-1 Entry into Set Up Mode

NOTE: If the upper display shows all decimal point positions illuminated, one or more of the critical configuration parameters - typically input range or output use/type - have been altered and, as a consequence, all Set Up Mode parameters have been automatically set to their default values/settings. To clear this display, simply alter the value/setting of any Set Up Mode parameter (see below).



## 2.2 SET UP MODE PARAMETERS

The parameter sequence or view/adjustment in Set Up Mode is shown in Table 2-1. Use the Function key to step through the parameters. In each case, the parameter legend will be shown in the lower display and the current value/setting will be shown in the upper display. The value/setting may be altered using the Raise/Lower keys. A detailed description of each of these parameters is given in the following Subsections.

Table 2-1 Set Up Mode Parameters

Parameter	Legend	Adjustment Range	Default Value
Limit Setpoint	<b>SP</b>	Range Max. To Range Min.	Range Max. (Hi Limit) Range Min. (Lo Limit)
Digital Filter Time Constant	<b>FILT</b>	OFF, 0.5 to 100.0 secs. In 0.5 sec. increments	2.0 seconds
Hysteresis	<b>HYST</b>	0% to 10% of input span	1 unit
Process High Alarm 1 value <sup>1</sup>	<b>H_A1</b>	Range Min. To Range Max.	Range Max.
Process Low Alarm 1 value <sup>1</sup>	<b>L_A1</b>	Range Min. To Range Max.	Range Min.
Band Alarm 1 value <sup>1</sup>	<b>B_A1</b>	0 to span from Limit SP	5 units
Deviation Alarm 1 value <sup>1</sup>	<b>D_A1</b>	±Span from Limit SP	5 units
Process High Alarm 2 value <sup>1</sup>	<b>H_A2</b>	Range Min. To Range Max.	Range Max.
Process Low Alarm 2 value <sup>1</sup>	<b>L_A2</b>	Range Min. To Range Max.	Range Min.
Band Alarm 2 value <sup>1</sup>	<b>B_A2</b>	0 to span from Limit SP	5 units
Deviation Alarm 2 value <sup>1</sup>	<b>D_A2</b>	±Span from Limit SP	5 units
Scale Range Maximum <sup>2</sup>	<b>rhi</b>	-1999 to 9999	1000
Scale Range Minimum <sup>2</sup>	<b>rLo</b>	-1999 to 9999	0000
Scale Range Decimal Point <sup>2</sup>	<b>rPnt</b>	0, 1, 2 or 3	1
Recorder Output Scale Maximum <sup>4</sup>	<b>roPH</b>	-1999 to 9999	Range Max.
Recorder Output Scale Minimum <sup>4</sup>	<b>roPL</b>	-1999 to 9999	Range Min.
Communications Enable <sup>3</sup>	<b>CoEn</b>	0 (Disabled) or 1 (Enabled)	1 (Enabled)
Display Enable	<b>d, SP</b>	0 (Disabled) or 1 (Enabled)	1 (Enabled)
Set Up Lock Code	<b>Loc</b>	0 to 9999	10
<i>Operator Mode Parameters (accessible in Set Up Mode):</i>			
Process Variable		Read Only	-
Alarm Status	<b>ALST</b>	Read Only (see Subsection 1.3)	-

**NOTES ON TABLE 2-1**

1. These parameters are optional; only one legend will appear for each alarm.
2. Only applicable if a DC Linear Input is fitted.
3. Only applicable if the Communications Option PCB is fitted.
4. Only applicable if Output 3 is a linear output.

### **2.2.1 Limit Setpoint**

This parameter defines the limit level. If the process variable goes above (for a High Limit) or below (for a Low Limit) this level (allowing for the setting of the Hysteresis parameter - see Subsection 2.2.3), the Limit Relay will be de-energised.

### **2.2.2 Input Filter Time Constant**

The Controller input has a digital filter which is used to filter out any extraneous impulses on the process variable. This filtered PV is used for all PV-dependent functions (control, alarms etc.). The time constant for this filter may be adjusted in the range 0.0 seconds (filter OFF) to 100.0 seconds in 0.5 second increments.

**CAUTION:** If this parameter is set to an excessively high value, the detection of a limit condition may be significantly delayed. The value chosen should be sufficiently large to attenuate stray noise on the process variable signal but no larger.

### **2.2.3 Hysteresis**

This parameter is used to prevent jitter in and out of the limit condition caused by small variations in the process variable value. It defines the amount by which, during a Limit condition, the process variable must come below (for a High Limit) or above (for a Low Limit) the Limit Setpoint before the Limit condition is cancelled.

**NOTE:** The Hysteresis is only active on the *exit* from the limit condition.

### **2.2.4 Process High Alarm 1/Alarm 2 Value**

These two parameters, applicable only when Alarm 1/Alarm 2 is selected to be a Process High alarm, defines the process variable value at or above which the alarm will be active. The operation of a process high alarm is illustrated in Figure 2-2.

### **2.2.5 Process Low Alarm 1/Alarm 2 Value**

These two parameters, applicable only when Alarm 1/Alarm 2 is selected to be a Process Low alarm, defines the process variable value at or below which the alarm will be active. The operation of a process low alarm is illustrated in Figure 2-2.

### **2.2.6 Band Alarm 1/Alarm 2 Value**

These two parameters, applicable only if Alarm 1/Alarm 2 is selected to be a Band Alarm, defines a band of process variable values, centred on the limit setpoint value. If the process variable value is outside this band, the alarm will be active. The operation of a band alarm is illustrated in Figure 2-2.

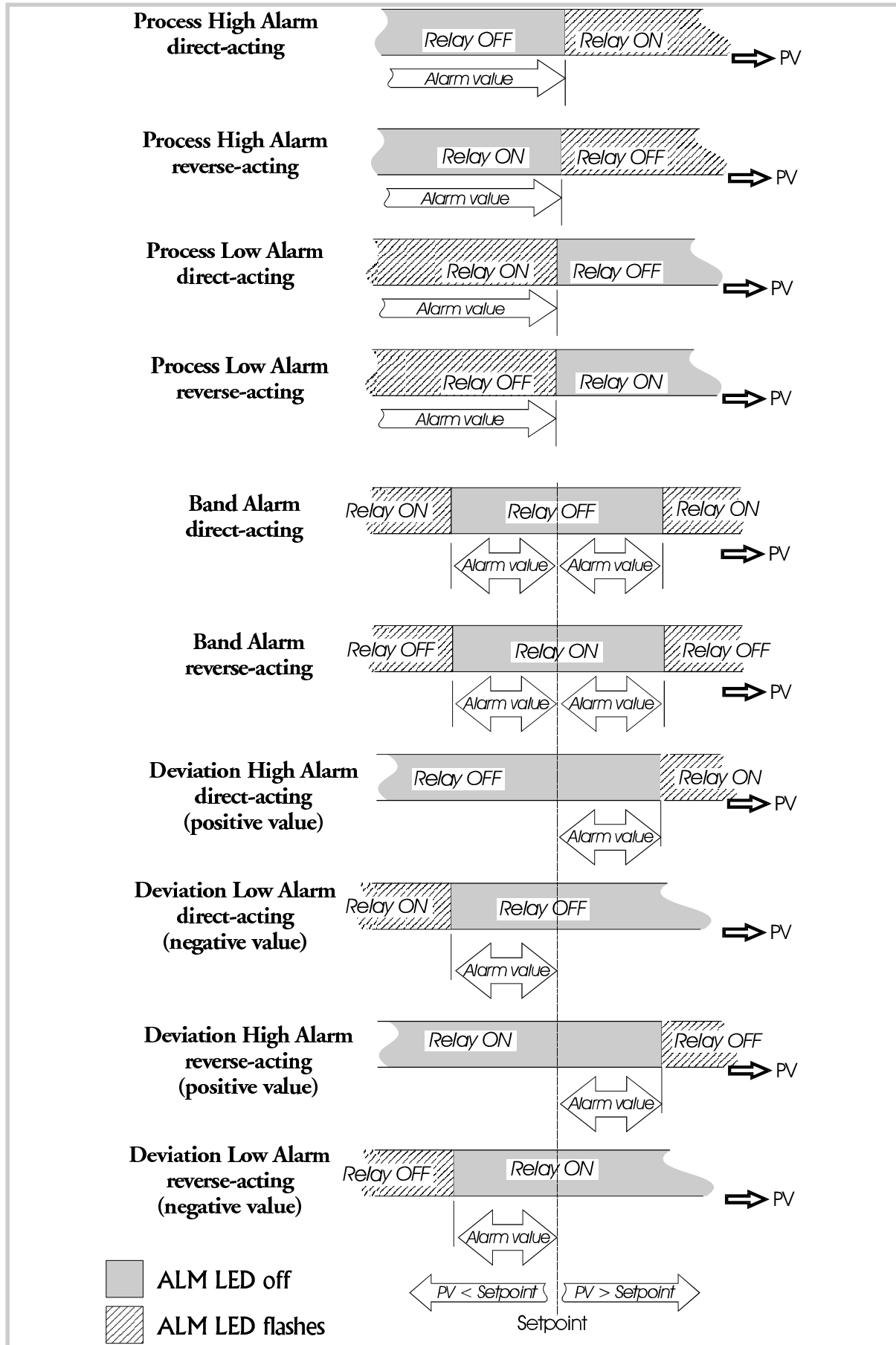

Figure 2-2 Alarm Operation

## 2.2.7 Deviation (High/Low) Alarm 1/Alarm 2 Value

These two parameters, applicable only if Alarm 1/Alarm 2 is selected to be a Deviation High/Low Alarm, defines a value above (positive value - Deviation High alarm) or below (negative value - Deviation Low alarm) the limit setpoint; if the process variable deviates from the limit setpoint by a margin greater than that defined by this parameter, the alarm goes active. The operation of Deviation Alarms is illustrated in Figure 2-2.

## 2.2.8 Scale Range Maximum

This parameter, applicable only if a linear input is fitted, defines the scaled input value when the process variable input hardware is at its maximum value. This parameter can be set to a value less than (but not equal to) Scale Range Minimum, in which case the sense of the input is reversed.

## 2.2.9 Scale Range Minimum

This parameter, applicable only if a linear input is fitted, defines the scaled input value when the process variable input hardware is at its minimum value. This parameter can be set to a value greater than (but not equal to) Scale Range Maximum, in which case the sense of the input is reversed.

## 2.2.10 Scale Range Decimal Point

This parameter, applicable only if a linear input is fitted, defines the position of the decimal point in values of the process variable, limit setpoint, alarm levels and recorder outputs as shown on the right.

Value	Decimal Point Position
0	XXXX
1	XXX.X
2	XX.XX
3	X.XXX

## 2.2.11 Recorder Output Scale Maximum

This parameter defines the value of process variable or limit setpoint (whichever is applicable) at which the Recorder Output reaches its maximum value; for example, for a 0 - 5V Recorder Output, this value corresponds to 5V. The decimal point position for the Recorder Output is always the same as that for the process variable input range.

NOTE: If this parameter is set to a value less than that for the Recorder Output Scale Minimum (see Subsection 2.2.12), the relationship between the process variable/limit setpoint value and the Recorder Output is reversed.

### 2.2.12 Recorder Output Scale Minimum

This parameter defines the value of the process variable or limit setpoint (whichever is applicable) at which the Recorder Output reaches its minimum value; for example, for a 0 - 5V Recorder Output, this value corresponds to 0V. The decimal point position for the Recorder Output is always the same as that for the process variable input range.

NOTE: If this parameter is set to a value greater than that for the Recorder Output Scale Maximum (see Subsection 2.2.11), the relationship between the process variable value and the Recorder Output is reversed.

### 2.2.13 Communications Enable/Disable

This parameter enables/disables Write operations (i.e. the *changing* of parameter values/settings) via the RS485 communications link, if the Communications Option PCB is fitted (0 = Disabled, 1 = Enabled). Parameters can be *interrogated* via the link, regardless of the setting of this parameter.

### 2.2.14 Display Enable

This parameter defines the normal content of the upper and lower displays in Operator Mode:

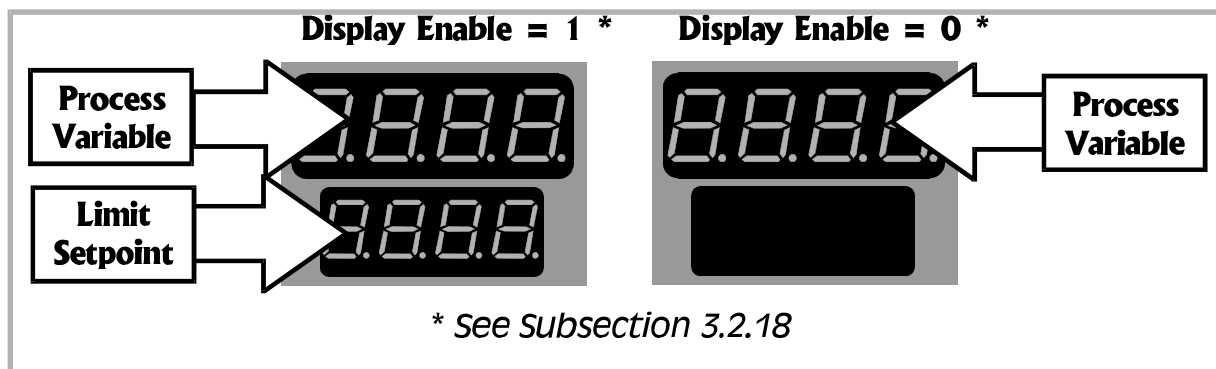

Figure 2-3 Display Enable Settings

### 2.2.15 Set Up Lock Code Value

This parameter defines the four-digit code required to enter Set Up Mode.

## 2.3 OPERATOR MODE DISPLAYS

Once the complete cycle of Set Up Mode parameters has been displayed, the user may then step through the Operator Mode displays (see Section 1), before re-starting the Set Up Mode parameter cycle, as shown in Table 2-1.

## 2.4 EXIT FROM SET UP MODE

To leave Set Up Mode, select the Process Variable Operator Mode display then depress the Raise and Function keys simultaneously, whereupon the **S** indicator will go OFF and the Controller will return to Operator Mode.

NOTE: An automatic return to Operator mode will be executed if there is no key activity in Set Up Mode for two minutes.



## **3 RS485 SERIAL COMMUNICATIONS**

The  $\frac{1}{16}$ -DIN Limit Controller may be equipped with a two-wire RS485-compatible serial communications facility, by which means communication may occur between the Controller and a master device (e.g. a computer or terminal).

### **3.1 COMMUNICATIONS ENABLE/DISABLE**

When Communications are enabled (in Set Up Mode - see Subsection 2.2.13), the Controller parameters may be adjusted by the master device via the serial communications link. If communications are disabled, the Controller will not adjust or change any parameters in response to commands received from the master device and will send a negative acknowledgement in response to such commands. Whether communications are enabled or disabled, the Controller will return the requested information in response to a Type 2 Interrogation message (see Subsection 3.2.5) from the master device.

### **3.2 PHYSICAL REQUIREMENTS**

#### **3.2.1 Character Transmission**

Data format is fixed to be even parity, seven data bits and one stop bit. The Baud rate may be selected to be 1200, 2400, 4800 (default) or 9600 Baud.

#### **3.2.2 Line Turn-Round**

The communications link is operated as a multi-drop half duplex system. When a device is transmitting, it drives the transmission lines to the appropriate levels; when it is not transmitting, its outputs are set to a high impedance in order that another device can transmit. It is important that a transmitter releases the transmission lines before another device starts transmission. This imposes the following restraints on the master device:

- (a) The transmitter must release the transmission lines within 6ms of the end of the last character of a message being transmitted. Note that delays due to buffers such as those used in universal asynchronous receivers/transmitters (UARTs) within the master device must be taken into account.
- (b) The transmitter must not start transmission until 6ms has elapsed since the reception of the last character of a message.

All Controllers in this range having an RS485 communications facility adhere to this standard; thus, provided that the master device conforms similarly to the standard, there should be no line contention problems.

### 3.2.3 Communications Protocol

The protocol assumes half duplex communications. All communication is initiated by the master device. The master sends a command or query to the addressed slave and the slave replies with an acknowledgement of the command or the reply to the query. All messages, in either direction, comprise:

- (a) A Start of Message character
- (b) One or two address characters (uniquely defining the slave)
- (c) A parameter/data character string
- (d) An End of Message character

Messages from the master device may be one of four types:

- Type 1: L {N} ? ? \*
- Type 2: L {N} {P} {C} \*
- Type 3: L {N} {P} # {DATA} \*
- Type 4: L {N} {P} I \*

Table 3-1 {DATA} Element - Sign and Decimal Point

{DATA} Content	Sign/Decimal Point
abcd0	+abcd
abcd1	+abc.d
abcd2	+ab.cd
abcd3	+a.bcd
abcd5	-abcd
abcd6	-abc.d
abcd7	-ab.cd
abcd8	-a.bcd

where all characters are in ASCII code and:

- L is the Start of Message character (Hex 4C)
- {N} is the slave Controller address (1 - 32); addresses 1 - 9 may be a single digit (e.g. 7) or in two-digit form, the first digit being zero (e.g. 07).
- {P} identifies the parameter to be interrogated/modified.
- {C} is the command (see below)
- # indicates that {DATA} is to follow (Hex 23)
- {DATA} is a string of numerical data in ASCII code (see Table 3-1)
- \* is the End of Message character (Hex 2A)

No space characters are permitted in messages. Any syntax errors in a received message will cause the slave controller to issue no reply and await the Start of Message character.

### 3.2.4 Type 1 Message

**L {N} ? ? \***

This message is used by the master device to determine whether the addressed slave Controller is active. The reply from the slave Controller, if it is active, is

**L {N} ? A \***

An inactive Controller will give no reply.

### 3.2.5 Type 2 Message

**L {N} {P} {C} \***

This type of message is used by the master device to interrogate or modify a parameter in the addressed Controller. {P} identifies the parameter (as defined in Subsection 3.3) and {C} represents the command to be executed, which may be one of the following:

- + (Hex 2B) - Increment the value of the parameter defined by {P}
- (Hex 2D) - Decrement the value of the parameter defined by {P}
- ? (Hex 3F) - Determine the current value of the parameter defined by {P}

The reply from the addressed Controller is of the form:

**L {N} {P} {DATA} A \***

where {DATA} comprises five ASCII-coded digits whose format is shown in Table 3-1. The data is the value requested in a query message or the new value of the parameter after modification. If the action requested by the message from the master device would result in an invalid value for that parameter (either because the requested new value would be outside the permitted range for that parameter or because the parameter is not modifiable), the Controller replies with a negative acknowledgement:

**L {N} {P} {DATA} N \***

The {DATA} string in the negative acknowledgement reply will be indeterminate. If the process variable or the deviation is interrogated whilst the process variable is outside the range of the Controller, the reply is **L{N}{P} <??> 0A\*** if the process variable is over-range, or **L{N}{P} <??> 5A\*** if the process variable is under-range.

### Scan Tables

A parameter identifier character “]” in the message from the master device indicates that a “Scan Table” operation is required. This provides a facility for

interrogating the values of a group of parameters and status in a single message from the master device. The reply to such a command would be in the form:

**L {N} 1 xx aaaaaa bbbbbb ccccc ddddd eeeee A \***

where xx is the number of data digits to follow and is always 25. The digits are expressed as shown in Table 3-1. For further information, refer to Subsection 3.3.5.

### 3.2.6 Type 3 Message

**L {N} {P} # {DATA} \***

This message type is used by the master device to set a parameter to the value specified in {DATA}. The command is not implemented immediately by the slave Controller; the slave will receive this command and will then wait for a Type 4 message (see below). Upon receipt of a Type 3 message, if the {DATA} content and the specified parameter are valid, the slave Controller reply is of the form:

**L {N} {P} {DATA} I \***

(where I = Hex 49) indicating that the Controller is ready to implement the command. If the parameter specified is invalid or is not modifiable or if the desired value is outside the permitted range for that parameter, the Controller replies with a negative acknowledgement in the form:

**L {N} {P} {DATA} N \***

### 3.2.7 Type 4 Message

**L {N} {P} I \***

This type of message is sent by the master device to the addressed slave Controller following a successful Type 3 message transmission and reply to/from the same slave Controller. Provided that the {DATA} content and the parameter specified in the preceding Type 3 message are still valid, the slave Controller will then set the parameter to the desired value and will reply in the form:

**L {N} {P} {DATA} A \***

where {DATA} is the new value of the parameter. If the new value or parameter specified is invalid, the slave Controller will reply with a negative acknowledgement in the form:

**L {N} {P} {DATA} N \***

where {DATA} is indeterminate. If the immediately-preceding message received by the slave Controller was not a Type 3 message, the Type 4 message is ignored.

### **3.3 INDIVIDUAL PARAMETERS**

The individual parameters and how they may be interrogated/modified are described below. Unless otherwise stated, the {DATA} element will follow the standard five-digit format and the decimal point position must be correct for the new value to be accepted and for modification to occur.

### 3.3.1 Input Parameters

Parameter	Identifier	Description
Process Variable	M	Read (Type 2 message) Only; If out of range, {DATA} will contain <??> <b>0</b> (over-range) or <??> <b>5</b> (under-range).
Scale Range Max.	G	Adjustable only on DC inputs. May be read (Type 2 message) or modified (Type 3/Type 4 message sequence). Decimal point position is as for the input range. <i>If less than Scale Range Min. Value, sense of input is reversed.</i>
Scale Range Min.	H	Adjustable only on DC inputs. May be read (Type 2 message) or modified (Type 3/Type 4 message sequence). Decimal point position is as for the input range. <i>If greater than Scale Range Max. Value, sense of input is reversed.</i>
Scale Range Decimal Point	Q	Adjustable on DC inputs only. May be read (Type 2 message) or modified (Type 3/Type 4 message sequence). Defines the decimal point position: 0 = abcd    1 = abc.d    2 = ab.cd 3 = a.bcd
Input Filter Time Constant	m	May be read or modified using a Type 2 message or a Type 3/Type 4 message sequence.
Hold Value	A	Minimum (Low Limit Action) or maximum (High Limit action) process variable value to occur since the Hold Value was last reset. Read Only (Type 2 message). May be reset by Controller Command 00160 (see Subsection 3.3.6).
Time Exceeded Value	T	The (accumulative) time during which the limit has been exceeded since this parameter was last reset to zero. Read Only (Type 2 message). May be reset using Controller Command 00170 (see Subsection 3.3.6).
Hysteresis	F	The amount, in a Limit Exceeded condition, by which the process variable must be below (High Limit action) or above (Low Limit action) the Limit Setpoint before the condition is cancelled. It may be read or modified (in the range 0% to 10% of input span) by a Type 2 message or a Type 3/Type 4 message sequence.

### 3.3.2 Output Parameters

Parameter	Identifier	Description
Recorder Output Scale Max.	[	May be read/modified by a Type 2 message or a Type 3/Type 4 message sequence. Corresponds to Input Scale Max. with decimal point position as for input. If less than Recorder Output Scale Min. sense of recorder output is reversed.
Recorder Output Scale Min.	\	May be read/modified by a Type 2 message or a Type 3/Type 4 message sequence. Corresponds to Input Scale Min. with decimal point position as for input. If greater than Recorder Output Scale Max. sense of recorder output is reversed.

### 3.3.3 Limit Setpoint Value

Parameter	Identifier	Description
Limit Setpoint	S	May be read/modified by a Type 2 message or a Type 3/Type 4 message sequence Can be set to any value in the input range.

### 3.3.4 Alarm Parameters

Parameter	Identifier	Description
Alarm 1 value	C	May be read/modified by a Type 2 message or a Type 3/Type 4 message sequence. Decimal point position is as for input range.
Alarm 2 value	E	May be read/modified by a Type 2 message or a Type 3/Type 4 message sequence. Decimal point position is as for input range.

For descriptions of the operation of the different alarm types, see Subsections 2.2.4 to 2.2.7 and Figure 2-2.

### 3.3.5 Status Parameters

Parameter	Identifier	Description
Controller Status	L	Read Only (Type 2 message). Status information is encoded in four digits as the decimal representation of a binary number; each bit in the binary number having a particular significance (see Figure 3-1).
Arithmetic Deviation	V	Read Only (Type 2 message). The difference between the process variable value and the Limit Setpoint value.
Scan Tables	] ]	Read Only (Type 2 message). Response: L{N}25aaaaabbbbbccccccddddeeeeeA* where: aaaaa = Limit Setpoint value bbbbb = Current process variable value ccccc = Current Hold Value (Max. Or Min. depending on Limit Action) ddddd = Current Time Exceeded eeeee = Controller Status (see Figure 3-1)

### 3.3.6 Controller Commands

Parameter	Identifier	Description				
Controller Commands	Z	<p>Implemented by Type 3/Type 4 message sequence only. In the Type 3 message, {DATA} must be one of three five-digit numbers:</p> <p>00150      Reset Limit Controller            00160      Reset Hold Value            00170      Reset Time Exceeded value to zero</p> <p>The response from the Limit Controller also contains the same {DATA} content, as does the response to the Type 4 message.</p> <p>A negative acknowledgement (NAK) will be returned under the following circumstances:</p> <table> <tr> <td>Reset Limit Controller</td> <td>(a) if the limit is exceeded but no annunciator output is configured. (b) Controller already reset</td> </tr> <tr> <td>Reset Time Exceeded</td> <td>Time Exceeded = 0 already</td> </tr> </table>	Reset Limit Controller	(a) if the limit is exceeded but no annunciator output is configured. (b) Controller already reset	Reset Time Exceeded	Time Exceeded = 0 already
Reset Limit Controller	(a) if the limit is exceeded but no annunciator output is configured. (b) Controller already reset					
Reset Time Exceeded	Time Exceeded = 0 already					



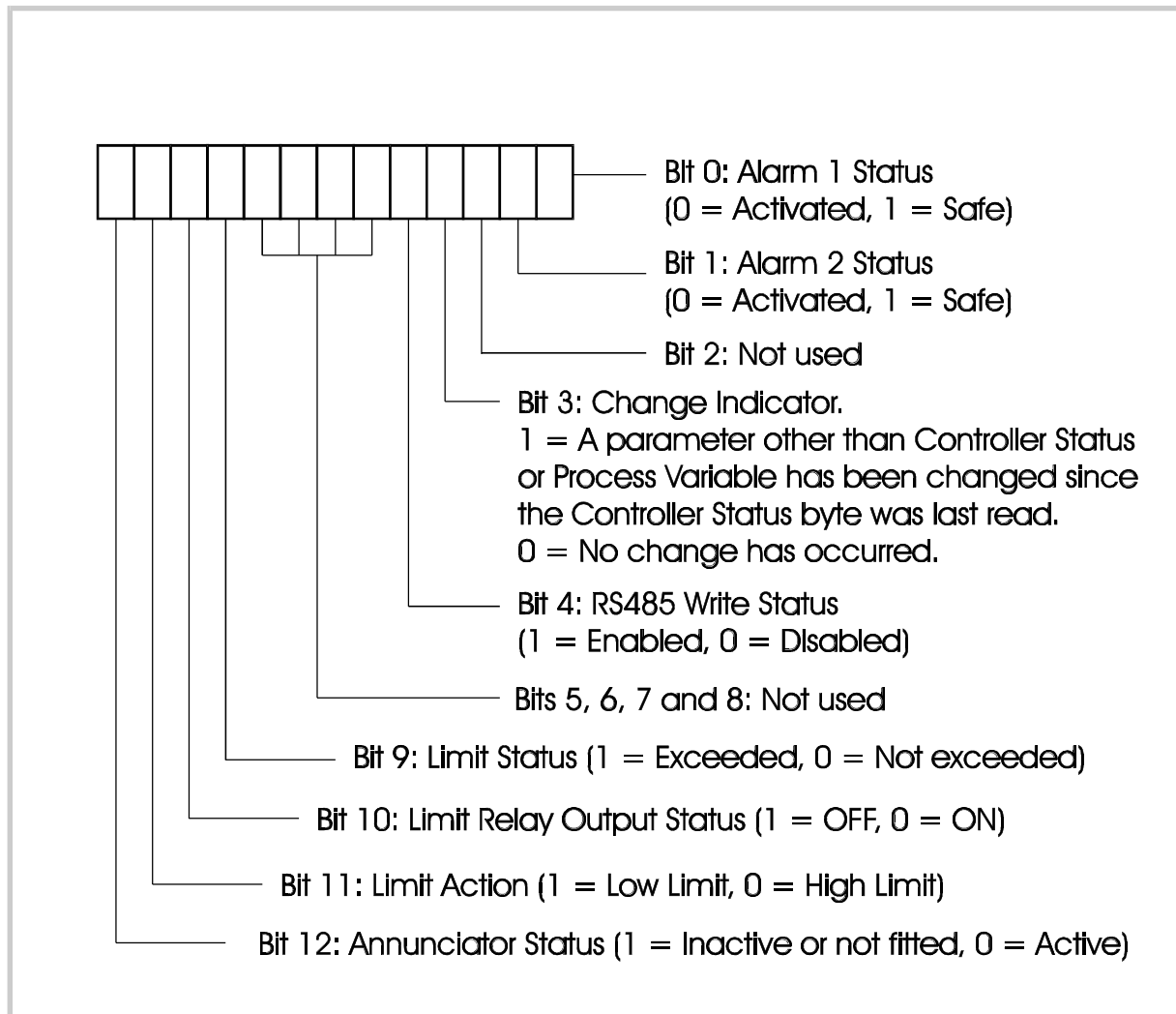

Figure 3-1 Controller Status Byte

### 3.4 ERROR RESPONSE

The circumstances under which a message from the master device is ignored are:

- Parity error detected
- Syntax error detected
- Timeout elapsed
- Receipt of a Type 4 message without a preceding Type 3 command message.

Negative acknowledgements will be returned if, in spite of the received message being notionally correct, the Limit Controller cannot supply the requested information or perform the requested operation. The {DATA} element of a negative acknowledgement will be indeterminate.

# ALPHABETIC INDEX

<b>A</b>	<b>D</b>
Alarm 1 Value	Data Format
Band alarm           2-4	Serial communications   3-1
Band Alarm           2-3	Decimal Point Position
Deviation alarm      2-6	Input scale range   2-3, 2-6
Deviation Alarm      2-3	Digital Filter Time Constant   2-3
Process High alarm    2-4	
Process High Alarm    2-3	<b>H</b>
Process Low alarm     2-4	Hardware Definition Code
Process Low Alarm     2-3	Display of           1-2
Alarm 2 Value	explanation of        1-2
Band alarm            2-3 - 2-4	Hold Value
Deviation alarm      2-3, 2-6	Display of           1-3
Process High alarm   2-3 - 2-4	Resetting           1-4
Process Low alarm    2-3 - 2-4	Hysteresis           2-3 - 2-4
Alarm Condition	
Indication of         1-4	<b>I</b>
Alarm Operation	
Illustration of       2-5	Input Filter Time Constant   2-4
Alarm Status	Input Over-range
Displaying (Operator Mode)	Indication of        1-2
1-1	Input Scale Range
Displaying (Set Up mode) 2-3	Decimal point position
	2-3, 2-6
<b>B</b>	Input Scale Range Maximum
Baud Rates	2-3, 2-6
Serial communications   3-1	Input Scale Range Minimum
	2-3, 2-6
	Input Under-range
<b>C</b>	indication of        1-2
Communications Line Release Time	
Maximum Value        3-1	<b>L</b>
Communications Message	Limit Condition
Command characters    3-3	Description of        1-3
Current Firmware Revision	Limit Setpoint          2-3 - 2-4
Display of            1-1	Limit Setpoint Display (Operator Mode)
	Enabling/disabling 2-3, 2-7

Linear Input	
Reversal of sense	2-6
Lock Code	
Set Up mode	2-3, 2-7

**O**

Operator Mode Initial Displays	1-1
--------------------------------	-----

**R**

Recorder Output	
Scale maximum	2-3
Recorder Output	
Reversal of sense	2-6
Scale maximum	2-6
Scale minimum	2-3, 2-7
Recorder Output	
Reversal of sense	2-7

**S**

Scan Tables Command	3-3
Sensor Break	
Indication of	1-2
Serial Communications	
Baud rates	3-1
Data format	3-1
Enabling/disabling	2-3, 2-7, 3-1
End of Message character	3-2
Error responses	3-9
Message format	3-2
Message types	3-2
Protocol	3-2
Start of Message character	3-2
Type 1 message	3-3
Type 2 message	3-3
Type 3 message	3-4
Type 4 message	3-4
Set Up Mode	
Automatic exit from	2-8

Entry into	2-1
Exit from	2-8
Lock code	2-3
Lock Code	2-7

## Set Up Parameters

"All At Default" indication	2-2
Adjusting	2-2
Viewing	2-2

**T**

## Time Exceeded Value

Display of	1-3
Resetting	1-4

# 1/4-DIN & 1/16-DIN LIMIT CONTROLLERS PRODUCT MANUAL

## VOLUME II INSTALLATION AND CONFIGURATION INSTRUCTIONS



The procedures described in this volume must be undertaken by technically-competent servicing personnel.

### Contents - Volume II

<b>1</b>	<b>INSTALLATION</b>	<b>1-1</b>
1.1	UNPACKING	1-1
1.2	PANEL-MOUNTING	1-1
1.3	CONNECTIONS AND WIRING	1-3
<b>2</b>	<b>INTERNAL LINKS AND SWITCHES</b>	<b>2-1</b>
2.1	REMOVING THE CONTROLLER FROM ITS HOUSING	2-1
2.2	REMOVING/REPLACING THE OUTPUT 2/3 OPTION PCBs	2-3
2.3	REMOVING/REPLACING THE RS485/REMOTE RESET OPTION PCB	2-3
2.4	REPLACING THE CONTROLLER IN ITS HOUSING	2-4
2.5	SELECTION OF INPUT TYPE	2-4
2.6	OUTPUT 3 TYPE	2-4
<b>3</b>	<b>CONFIGURATION MODE</b>	<b>3-1</b>
3.1	ENTRY INTO CONFIGURATION MODE	3-1
3.2	HARDWARE DEFINITION CODE	3-2

3.3	OPTION SELECTION	3-3
3.4	CONFIGURATION MODE PARAMETERS	3-4
3.5	EXIT FROM CONFIGURATION MODE	3-5

## **Appendices**

A	PRODUCT SPECIFICATION	A-1
---	-----------------------	-----

# 1 INSTALLATION

**WARNING:** The functions defined in this Section should be performed only by personnel who have been trained and authorised for that purpose.

## 1.1 UNPACKING

1. Unpack the Limit Controller. It is supplied with a panel gasket and push-fit fixing strap. Retain the packing for future use, should it be necessary to transport the Controller to a different site or to return it to the supplier for repair/testing.

2. Examine the delivered items for damage or deficiencies. If any is found, notify the carrier immediately.

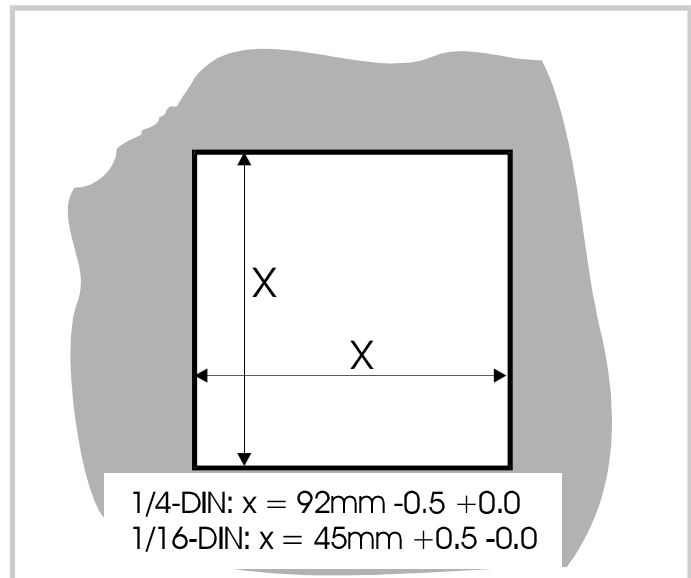

Figure 1-1 Panel Cut-Out (Single Unit)

## 1.2 PANEL-MOUNTING

The mounting panel must be rigid and may be up to 6.0mm (0.25 inches) thick. The cut-out required for a single Limit Controller is shown in Figure 1-1. Several controllers may be installed in a single cut-out, side-by-side. For  $n$  Controllers, the width of the cut-out would be (a)  $(48n - 4)$  mm or  $(1.89n - 0.16)$  inches for  $\frac{1}{16}$ -DIN Controllers or (b)  $(96n - 4)$ mm or  $(3.78n - 0.16)$  inches for  $\frac{1}{4}$ -DIN Controllers. The main dimensions of the Limit Controller are shown in Figure 1-2.

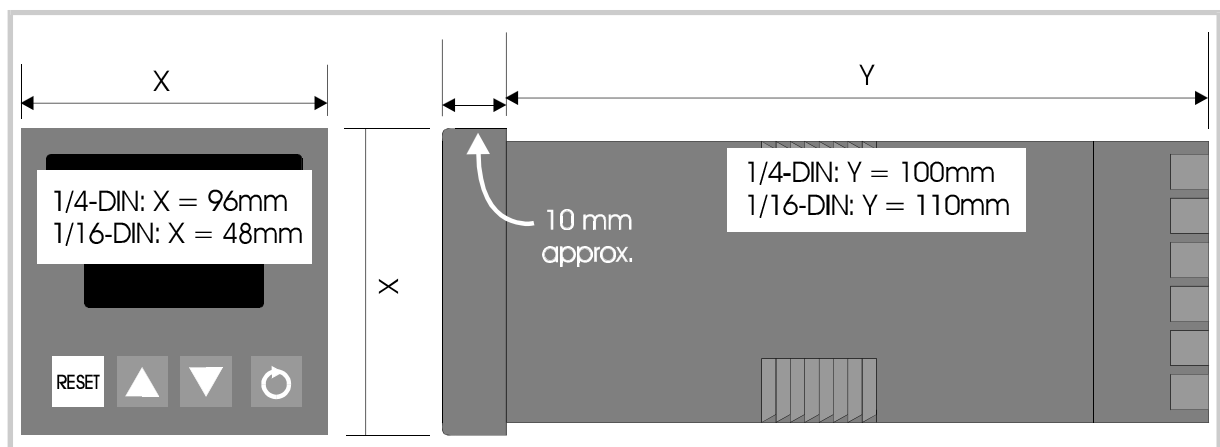

Figure 1-2 Main Dimensions

The procedure to panel-mount the Controller is shown in Figure 1-3.

**CAUTION:** Do not remove the panel gasket, as this may result in inadequate clamping of the instrument in the panel.

**NOTE:** The mounting clamp tongues may engage the ratchets either on the sides of the Controller housing or on the top/bottom faces of the Controller housing. Therefore, when installing several Controllers side-by-side in one cut-out, use the ratchets on the top/bottom faces.

Once the Controller is installed in its mounting panel, it may be subsequently removed from its housing, if necessary, as described in Subsection 2.1.

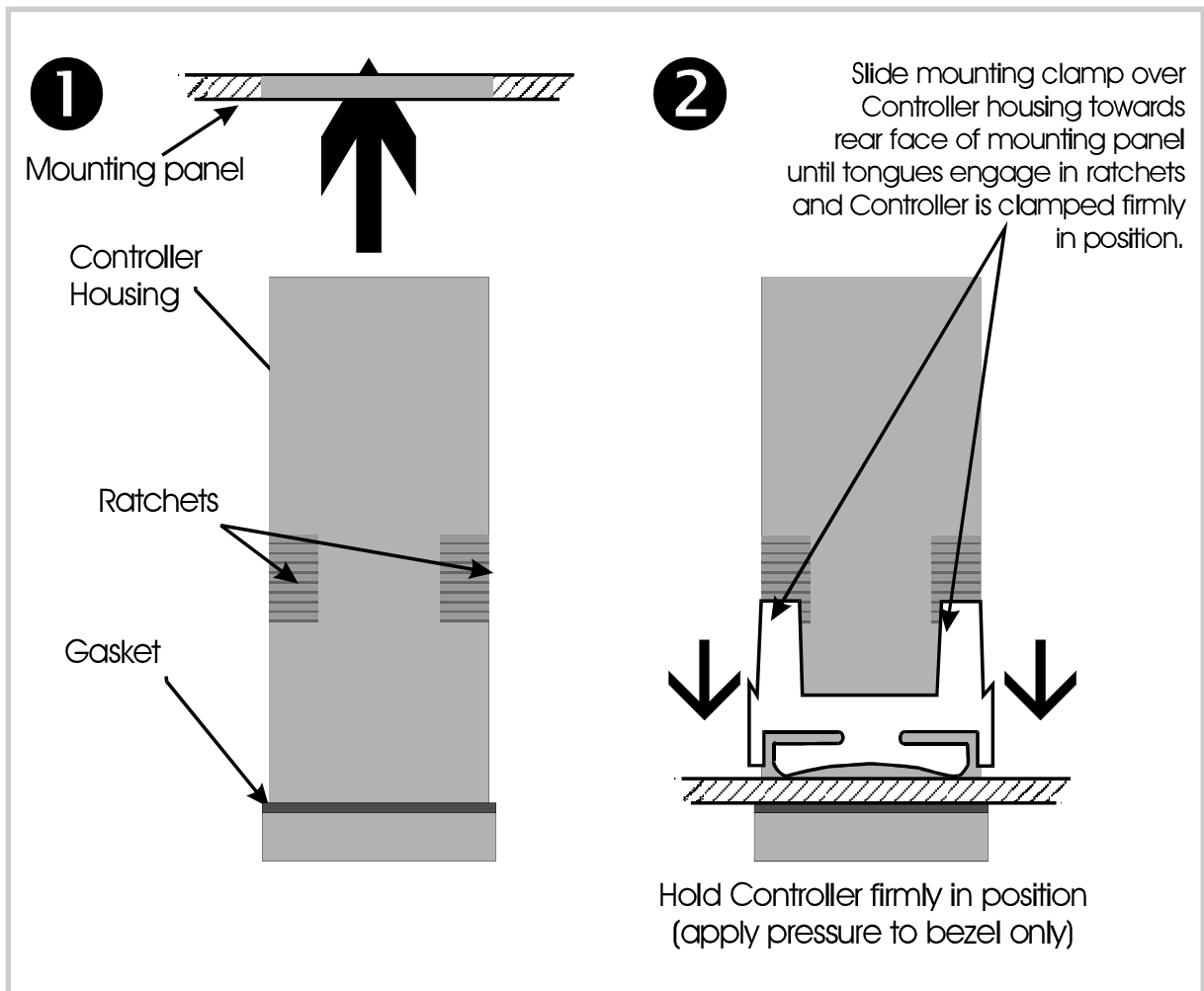

Figure 1-3 Panel-Mounting the Limit Controller

## 1.3 CONNECTIONS AND WIRING

The rear terminal connections are illustrated in Figures 1-4 ( $\frac{1}{16}$ -DIN instrument) and 1-5 ( $\frac{1}{4}$ -DIN instrument).

### 1.3.1 Mains (Line) Supply

The Limit Controller will operate on 96 - 264V AC 50/60Hz mains (line) supply. The power consumption is approximately 4 VA.

**CAUTION:** This equipment is designed for installation in an enclosure which provides adequate protection against electric shock. Local regulations (e.g. National Electrical Code, British Standards) regarding electrical installation should be rigidly observed. Consideration should be given to prevention of access to the power terminations by unauthorised personnel. Power should be connected via a two-pole isolating switch (preferably situated near the equipment) and a 1A fuse (see Figure 1-4 or Figure 1-5).

If the Controller has relay outputs in which the contacts are to carry mains (line) voltage, it is recommended that the relay contact mains (line) supply should be switched and fused in a similar manner to (but should be separate from) the Controller mains (line) supply.

### 1.3.2 24V AC/DC Supply

Power should be connected via a two-pole isolating switch and a 1A slow-blow fuse.

### 1.3.3 Thermocouple Input

The correct type of thermocouple extension leadwire or compensating cable must be used for the entire distance between the Controller and the thermocouple, ensuring that the correct polarity is observed throughout. Joints in the cable should be avoided, if possible. The Controller's CJC facility must be enabled (normal conditions) for this input (see Subsection 3.4).

**NOTE:** Do not run thermocouple cables adjacent to power-carrying conductors. If the wiring is run in a conduit, use a separate conduit for the thermocouple wiring. If the thermocouple is grounded, this must be done at one point only. If the thermocouple extension lead is shielded, the shield must be grounded at one point only.



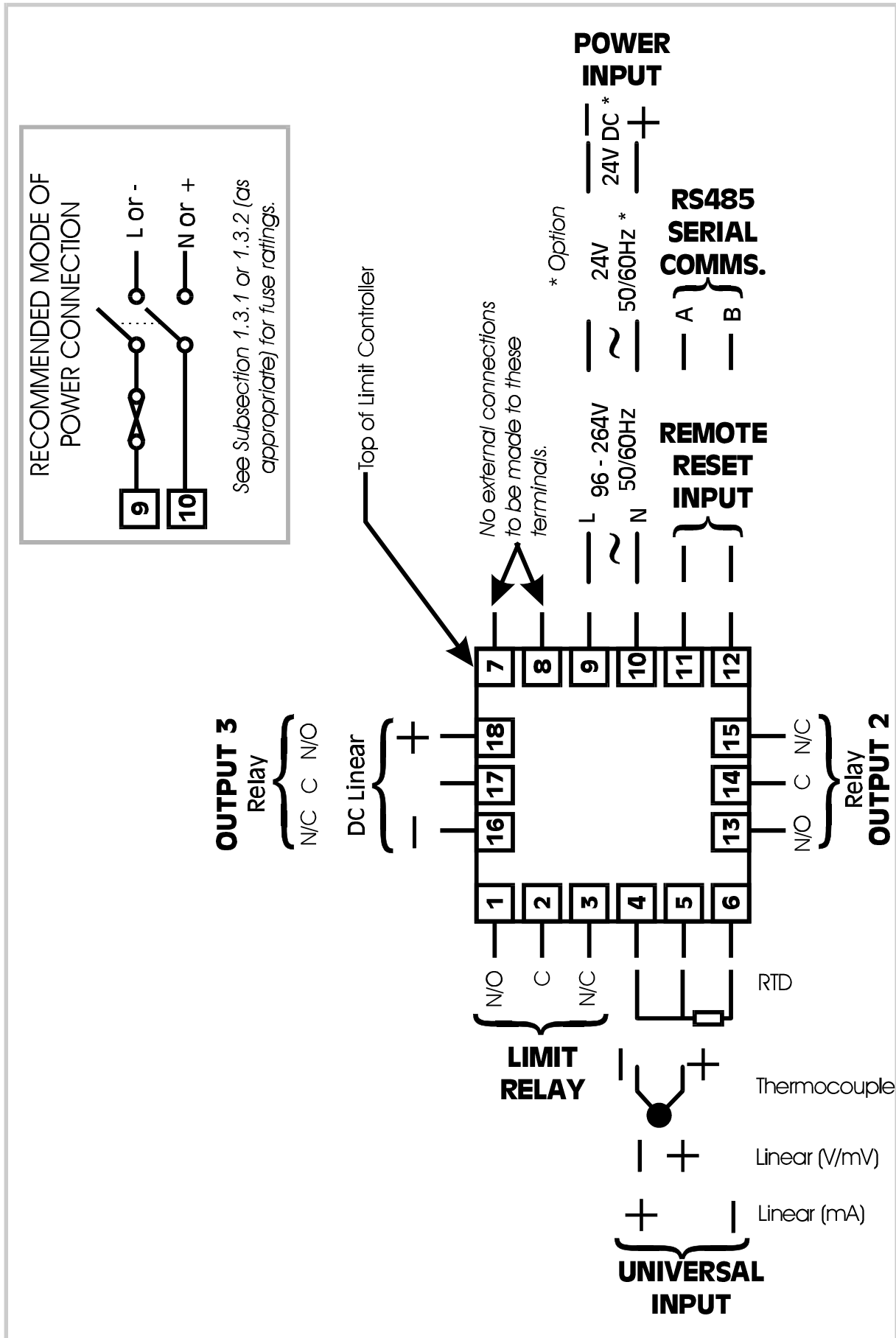

Figure 1-4 Rear Terminal Connections ( $\frac{1}{16}$ -DIN Limit Controller)

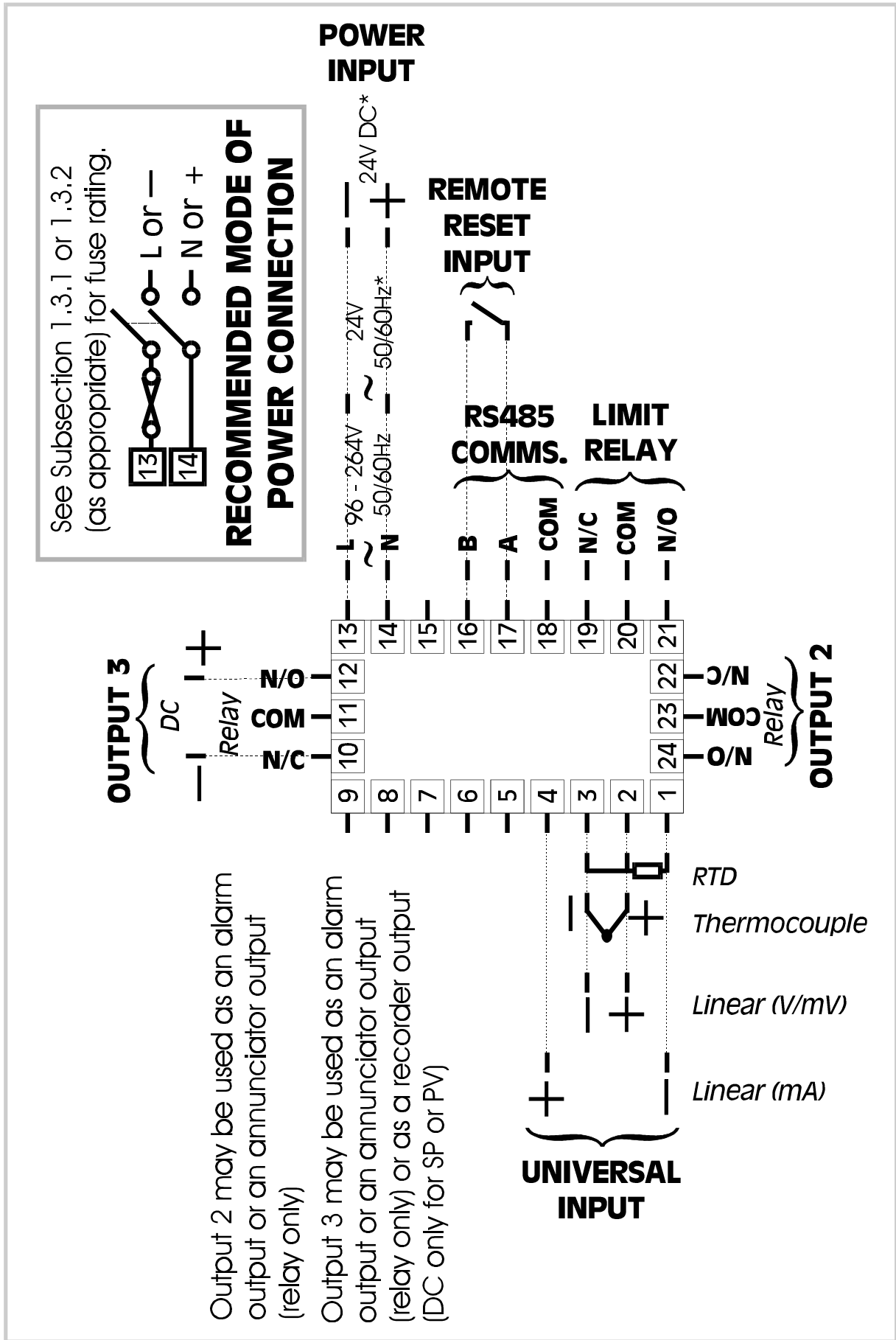

Figure 1-5 Rear Terminal Connections (1/4-DIN Limit Controller)

### **1.3.4 RTD Inputs**

The compensating lead should be connected to Terminal 4. For two-wire RTD inputs, Terminals 4 and 5 should be linked. The extension leads should be of copper and the resistance of the wires connecting the resistance element should not exceed 5 ohms per lead (the leads should be of equal length).

### **1.3.5 Remote Reset Input**

Terminals 11 and 12 may be connected to an external pair of voltage-free contacts (e.g. relay or manually-operated switch). Closure of the contacts will cause a Reset (acknowledgement of a Limit condition), identical in effect to depression of the **RESET** key. This optional facility is mutually exclusive with the RS485 serial communications option.

### **1.3.6 Limit Relay Output**

The contacts are rated at 5A resistive at 120/240V AC.

### **1.3.7 Alarm or Annunciator Relay Outputs**

The contacts are rated at 2A resistive at 120/240V AC.

### **1.3.8 Re-Transmitted (Recorder) DC Outputs**

See Figure 1-4 or Figure 1-5 and Appendix A.

### **1.3.9 RS485 Serial Communications Link**

The "A" terminal on the Controller should be connected to the "A" terminal on the master device; the "B" terminal on the Controller should be connected to the "B" terminal on the master device. Where several Controllers are connected to one master port, the master port transceiver in the active state should be capable of driving a load of 12k $\Omega$  per Controller; the master port transceiver in the passive state must have pull-up/pull-down resistors of sufficiently low impedance to ensure that it remains in the quiescent state whilst supplying up to  $\pm 100\mu\text{A}$  each to the Controller transceivers in the high impedance state.

This optional facility is mutually exclusive with the Remote Reset option.

## 2 INTERNAL LINKS AND SWITCHES

NOTE: The operations described in this Section should be performed only by personnel trained and authorised to do so.

### 2.1 REMOVING THE CONTROLLER FROM ITS HOUSING

To withdraw the Limit Controller from its housing, simply grip the side edges of the front panel (there is a finger grip on each edge) and pull the Controller forwards. This will release the Controller from its rear connectors in the housing and will give access to the Controller PCBs. Take note of the orientation of the Controller for subsequent replacement into the housing. The positions of the PCBs in the Controller are shown in Figure 2-1.

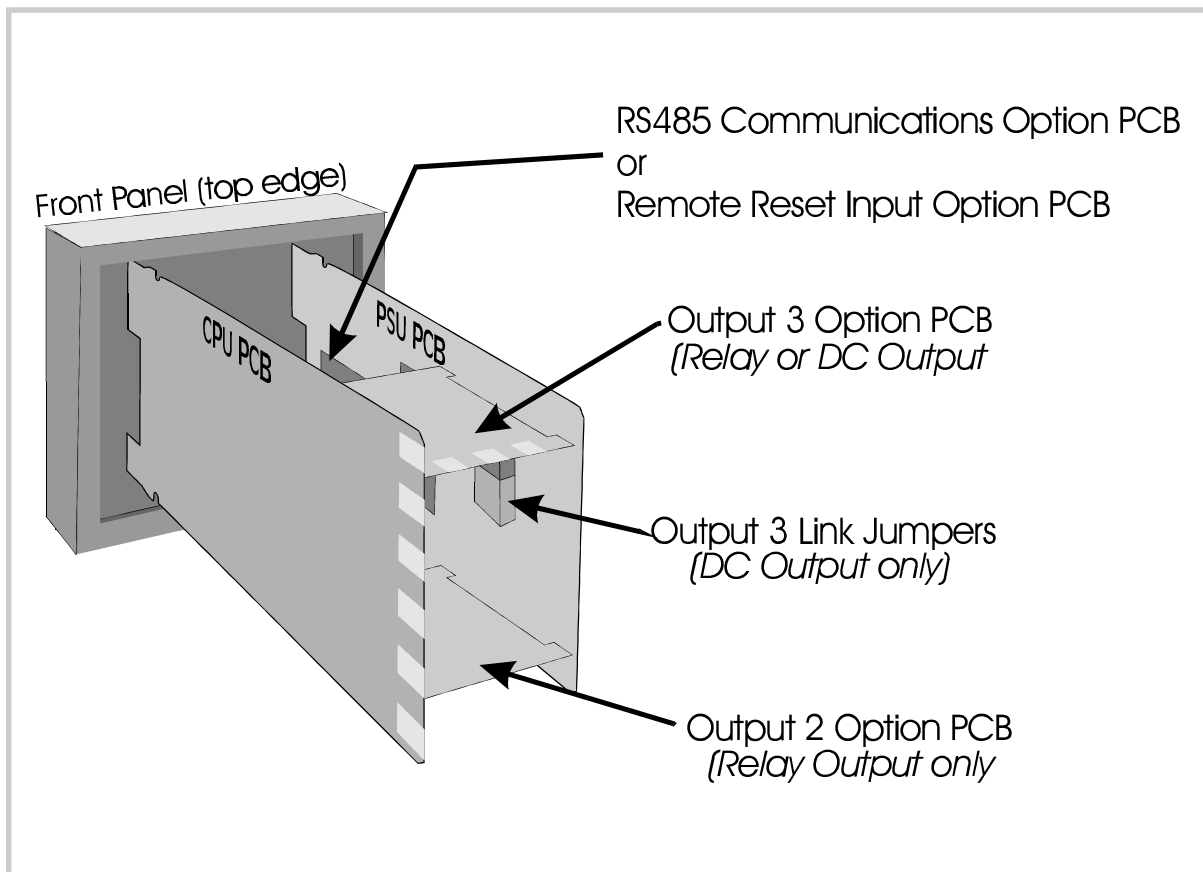

Figure 2-1 PCB Positions

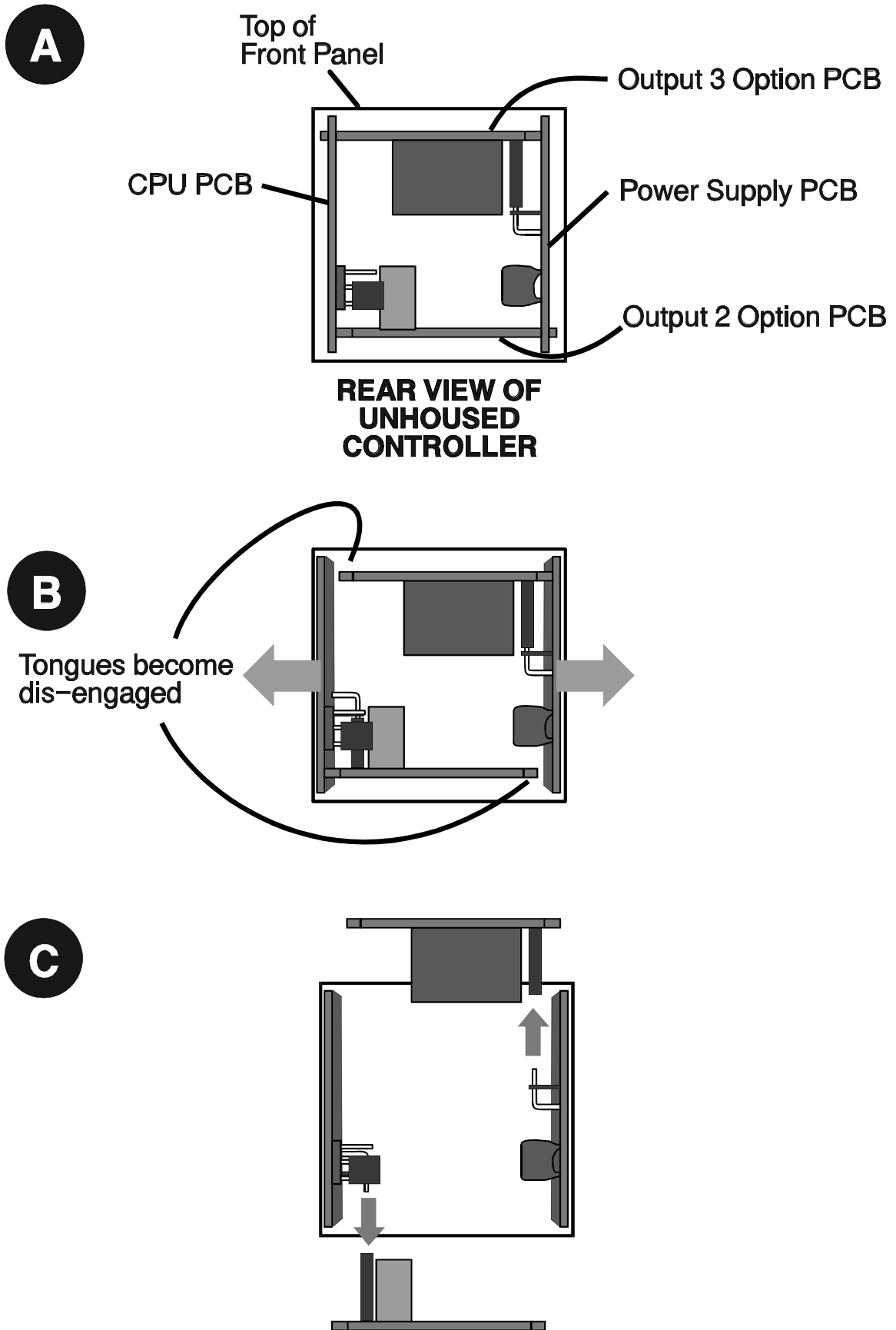

Figure 2-2 Removing the Output 2 Option PCB/Output 3 Option PCB

## 2.2 REMOVING/REPLACING THE OUTPUT 2/3 OPTION PCBs

With the Controller removed from its housing:

1. Gently push the rear ends of the CPU PCB and PSU PCB apart slightly, until the two tongues on each PCB become dis-engaged - see Figure 2-2B; The Output 2 Option PCB tongues engage in holes in the PSU PCB and the Output 3 Option PCB tongues engage in holes on the CPU PCB.
2. Carefully pull the required PCB from its connector (Output 2 Option PCB is connected to the CPU PCB and Output 3 Option PCB is connected to the PSU PCB) - see Figure 2-2C. Note the orientation of the PCB for later replacement.

The link jumpers on the CPU PCB and on the Output 3 Option PCB (if DC output is fitted) are now accessible. Replacement is a reversal of the removal procedure.

## 2.3 REMOVING/REPLACING THE RS485/REMOTE RESET OPTION PCB

The RS485 Communications Option PCB or the Remote Reset Input Option PCB (they are mutually exclusive) is mounted on the inner surface of the PSU PCB. Figure 2-3 illustrates the removal/replacement procedure. *It is not necessary to remove the Output 2/Output 3 Option PCBs to perform this procedure.*

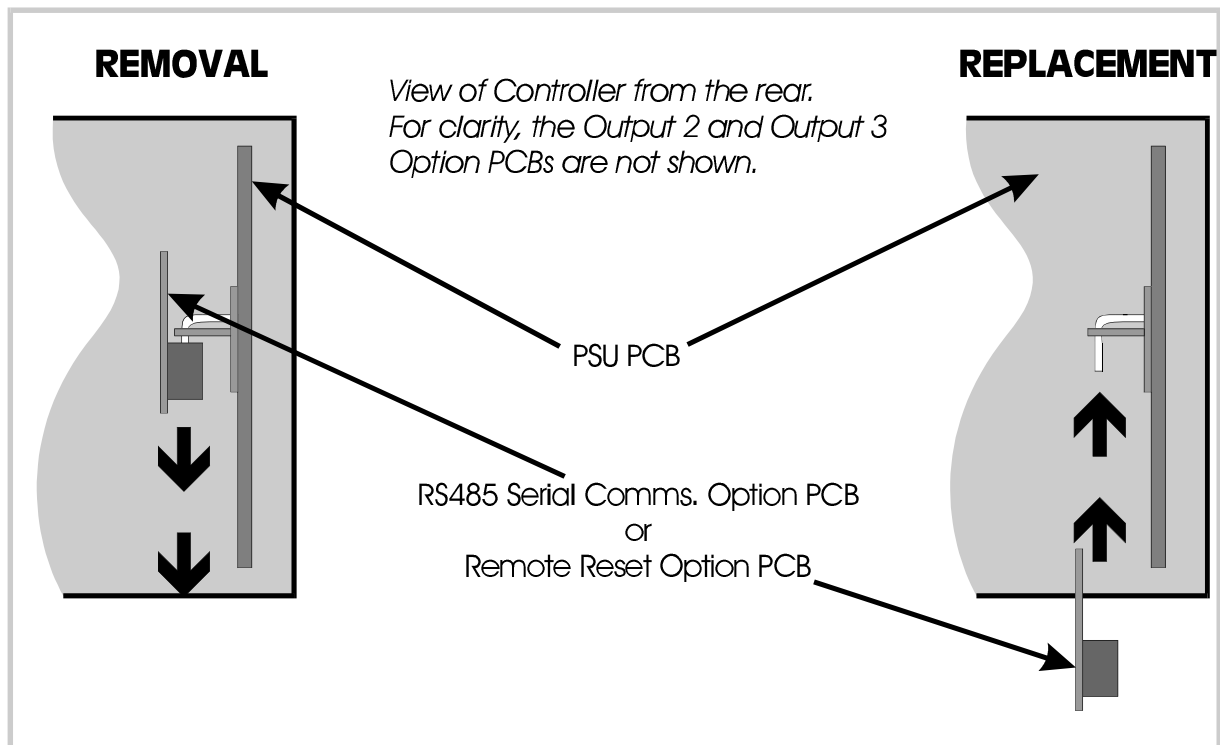

Figure 2-3 Removing the RS485 Serial Comms Option PCB or Remote Reset Option PCB

## 2.4 REPLACING THE CONTROLLER IN ITS HOUSING

To replace the Controller, simply align the CPU PCB and PSU PCB with their guides and connectors in the housing and slowly but firmly push the Controller into position.

**CAUTION:** Ensure that the instrument is correctly orientated. A stop will operate if an attempt is made to insert the instrument in the wrong orientation (e.g. upside-down). *This stop must not be over-ridden.*

## 2.5 SELECTION OF INPUT TYPE

The selection of input type is accomplished on link jumpers on the CPU PCB (see Figure 2-4).

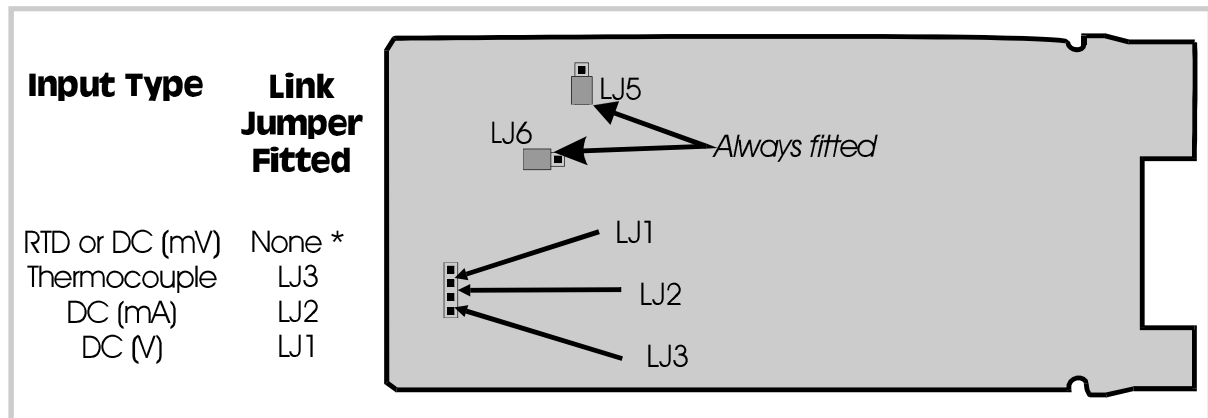

Figure 2-4 CPU PCB Link Jumpers - Input Type Selection

## 2.6 OUTPUT 3 TYPE

The type of output for Output 3 is determined by the Output 3 Option PCB fitted (see Figure 2-1). There are two types of option PCB which may be used for Output 3:

1. Relay Output Option PCB (no link jumpers) - Alarm or Annunciator output only.
2. DC Output Option PCB (link jumpers as shown in Figure 2-5) - Recorder output only.

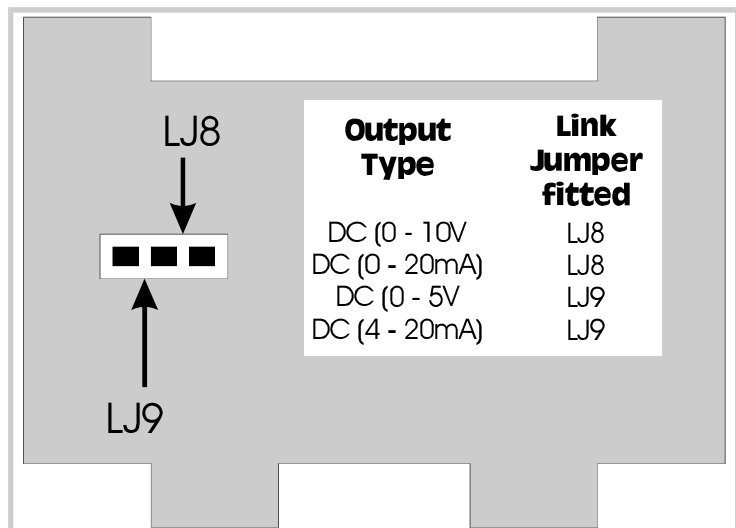

Figure 2-5 DC Output 3 Option PCB - Link Jumpers

## 3 CONFIGURATION MODE

### 3.1 ENTRY INTO CONFIGURATION MODE

See Figure 3-1.

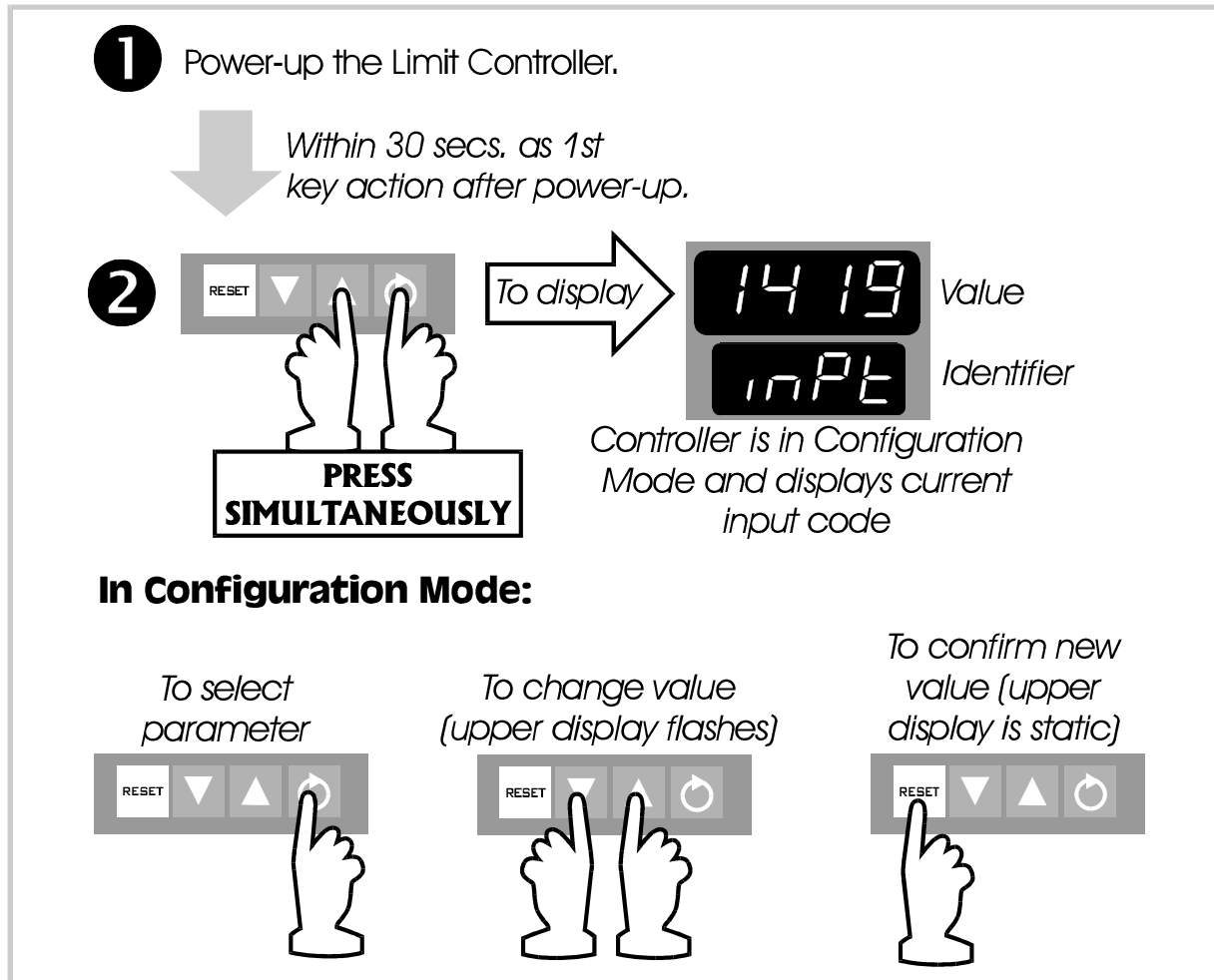

Figure 3-1 Entry into Configuration Mode

**NOTE:** Changes to the value/setting of certain Configuration Mode parameters (e.g. input range, output use and type) will cause the Set Up Mode parameters to be automatically set to their default values the next time Set Up Mode is entered (see also Volume I, Subsection 2.1).



### 3.2 HARDWARE DEFINITION CODE

This parameter is a special facility in Configuration Mode, which is used to represent the hardware fitted (input type, Output 2 type and Output 3 type); this must be compatible with the hardware actually fitted. For access to, and adjustment of, the Hardware Definition Code, see Figure 3-2.

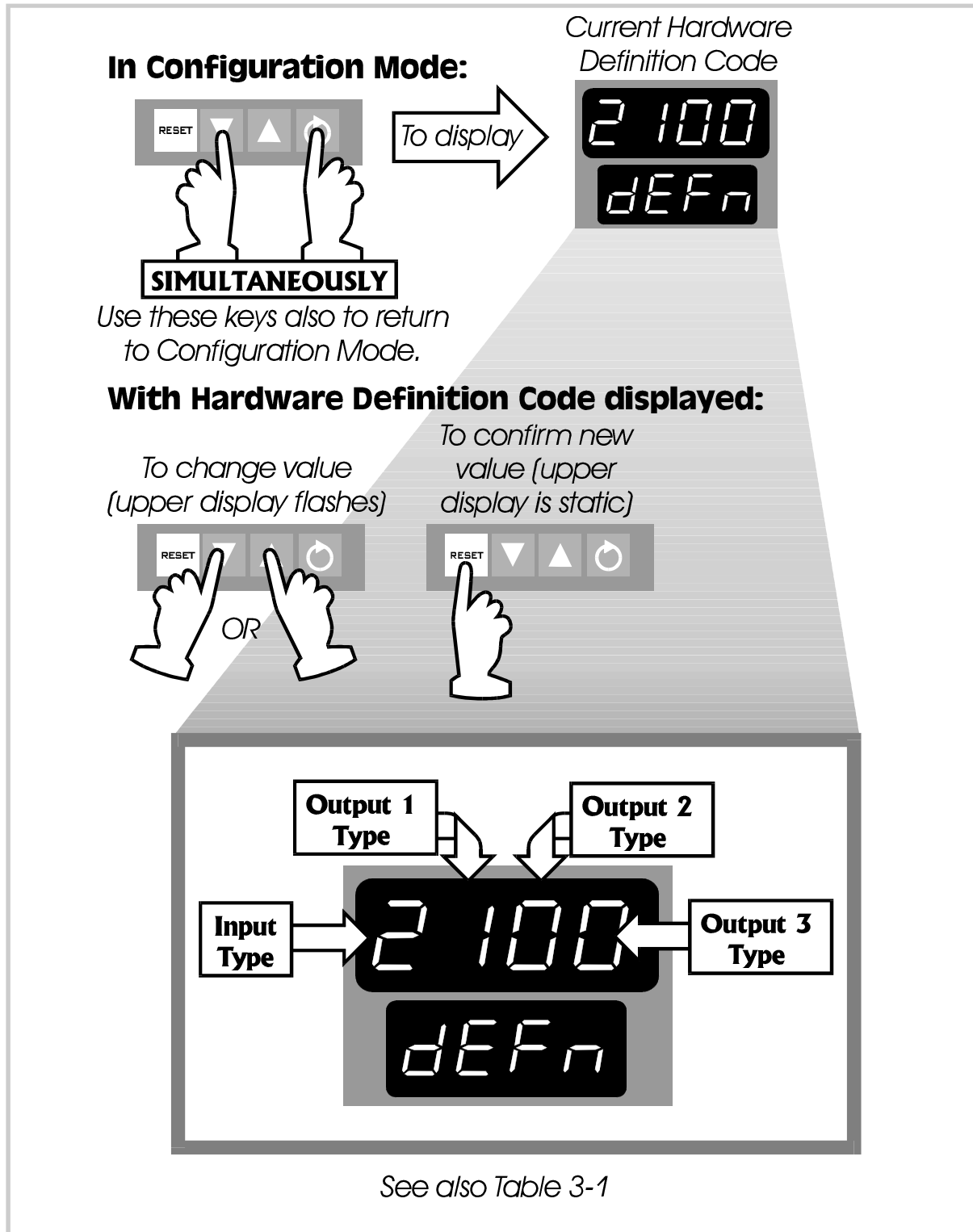

Figure 3-2 Hardware Definition Code - Access and Adjustment

Table 3-1 Hardware Definition Code - Input/Output Type Selection

Value	0	1	2	3	4	5	7
Input		RTD/ Linear	T/couple	Linear (mA)	Linear (V)		
Output 1		Relay					
Output 2/3	Not fitted	Relay	SSR Drive	DC (0-10V)	DC (0-20mA)	DC (0-5V)	DC (4-20mA)

The maximum setting available for this code is 4117. For example, the code for a thermocouple input, and relay Output 3 would be 2101.

NOTE: It is essential that this code is changed promptly whenever there is a change to the Controller's hardware configuration (change of input/output type, alarm/recorder output added/removed etc.). The Controller software depends upon this code to ensure that the Controller operates correctly.

This code may be viewed as a Read Only display in Operator Mode (see Volume I, Subsection 1.6).

### 3.3 OPTION SELECTION

This indicates the presence/absence of the Communications Options PCB or Remote Reset Options PCB and is accessed whilst the Hardware Definition Code is displayed (see Figure 3-3).

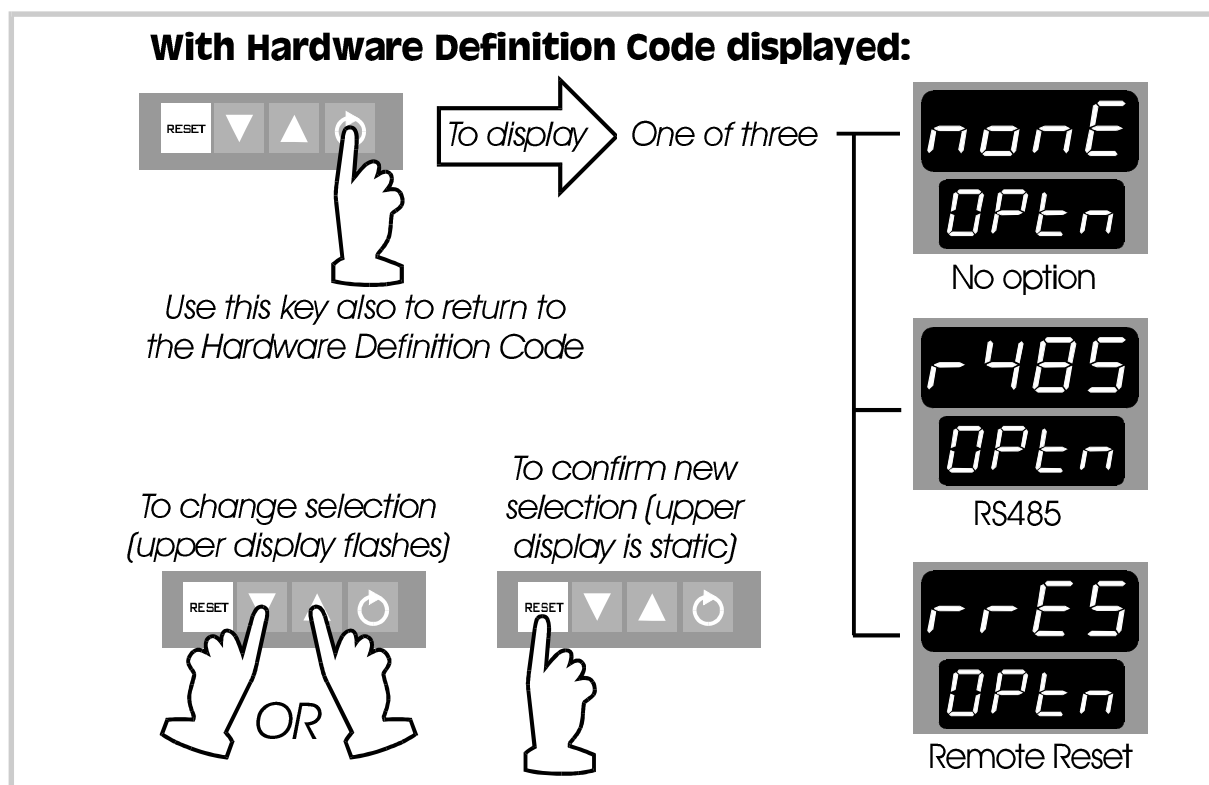

Figure 3-3 Option Selection

### 3.4 CONFIGURATION MODE PARAMETERS

Parameter	Identifier	Description
Input Range	<b>inPt</b>	A four-digit code (see Appendix A). Default settings: Thermocouple - 1419 (Type J, 0 - 761°C) RTD/Linear mV - 7220 (RTD Pt100 0 - 800°C) Linear mA - 3414 (4 - 20mA) Linear V - 4446 (0 - 10V)
Limit Action	<b>Ctrl Hi</b>	High Limit (default) energised when process is safe
	<b>Lo</b>	Low Limit energised when process is safe
Alarm 1 Type	<b>AL1P_hi</b>	Process High Alarm (default)
	<b>P_Lo</b>	Process Low Alarm
	<b>dE</b>	Deviation Alarm
	<b>bAnd</b>	Band Alarm
	<b>nonE</b>	No alarm
Alarm 2 Type	<b>AL2P_hi</b>	Process High Alarm
	<b>P_Lo</b>	Process Low Alarm (default)
	<b>dE</b>	Deviation Alarm
	<b>bAnd</b>	Band Alarm
	<b>nonE</b>	No alarm
Output 2 Usage	<b>USE2AI_d</b>	Alarm 1 hardware output, direct-acting (default)
	<b>AI_r</b>	Alarm 1 hardware output, reverse-acting
	<b>A2_d</b>	Alarm 2 hardware output, direct-acting
	<b>A2_r</b>	Alarm 2 hardware output, reverse-acting
	<b>Or_d</b>	Direct-acting output, Logic OR of Alarm 1 & Alarm 2
	<b>Or_r</b>	Reverse-acting output, Logic OR of Alarm 1 & Alarm 2
	<b>Ad_d</b>	Direct-acting output, Logic AND of Alarm 1 & Alarm 2
	<b>Ad_r</b>	Reverse-acting output, Logic AND of Alarm 1 & Alarm 2
	<b>An_d</b>	Limit Annunciator, relay output, direct-acting
	<b>An_r</b>	Limit Annunciator, relay output, reverse-acting

Parameter	Identifier	Description
Output 3 Usage	<b>USE3</b>	
	<b>AI_d</b>	Alarm 1 hardware output, direct-acting (relay output only)
	<b>AI_r</b>	Alarm 1 hardware output, reverse-acting (relay output only)
	<b>A2_d</b>	Alarm 2 hardware output, direct-acting (relay output only) - default for relay output
	<b>A2_r</b>	Alarm 2 hardware output, reverse-acting (relay output only)
	<b>Or_d</b>	Direct-acting output, Logic OR of Alarm 1 & Alarm 2 (relay output only)
	<b>Or_r</b>	Reverse-acting output, Logic OR of Alarm 1 & Alarm 2 (relay output only)
	<b>Ad_d</b>	Direct-acting output, Logic AND of Alarm 1 & Alarm 2 (relay output only)
	<b>Ad_r</b>	Reverse-acting output, Logic AND of Alarm 1 & Alarm 2 (relay output only)
	<b>An_d</b>	Limit Annunciator output, direct-acting (relay output only)
	<b>An_r</b>	Limit Annunciator output, reverse-acting (relay output only)
	<b>rEcS</b>	Recorder output - Limit Setpoint (DC output only)
	<b>rEcP</b>	Recorder Output - Process Variable (DC output only) - default for DC output
Comms. Baud Rate	<b>bAud</b>	Selectable: 1200, 2400, 4800, 9600 Baud
Comms. Address	<b>Addr</b>	Unique address assigned to the Controller. In the range 1 - 32.
Cold Junction Compensation Enable/Disable	<b>CJCEnAb</b>	Enabled (default)
	<b>dISA</b>	Disabled
Lock Code	<b>Loc</b>	Read Only display of four-digit Set Up Mode Lock Code

*NOTE: The Cold Junction Compensation Enable/Disable parameter appears in the parameter sequence only if the Input selected (see Hardware Definition Code) is Thermocouple.*

### 3.5 EXIT FROM CONFIGURATION MODE

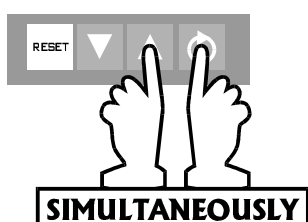

**NOTE:** An automatic exit to Operator Mode will be made if, in Configuration Mode, there is no front panel key activity for two minutes.

The exit is made via the power-up self-test routines which include a lamp test.

# A PRODUCT SPECIFICATION

## A.1 UNIVERSAL INPUT

### General

Maximum per Controller:	One
Input Sample Rate:	Four samples/second
Digital Input Filter:	Time constant selectable from front panel - 0.0 (i.e. OFF), 0.5 to 100.0 seconds in 0.5-second increments.
Input Resolution:	14 bits approximately; always four times better than display resolution.
Input Impedance:	Greater than 100M $\Omega$ resistive (except for DC mA and V inputs).
Isolation:	Universal input isolated from all outputs except SSR at 240V AC.

**Thermocouple:** Ranges selectable from front panel (with displayed codes):

Type	Input Range	Displayed Code	Type	Input Range	Displayed Code
R	0 - 1650°C	1127	J	32 - 1401°F	1420
R	32 - 3002°F	1128	T	-200 - 262°C	1525
S	0 - 1649°C	1227	T	-328 - 503°F	1526
S	32 - 3000°F	1228	T	0.0 - 260.6°C	1541
J	0.0 - 205.4°C	1415	T	32.0 - 501.0°F	1542
J	32.0 - 401.7°F	1416	K	-200 - 760°C	6726
J	0 - 450°C	1417	K	-328 - 1399°F	6727
J	32 - 842°F	1418	K	-200 - 1373°C	6709
J	0 - 761°C *	1419	K	-328 - 2503°F	6710

\* Default

*Continued overleaf.....*

Type	Input Range	Displayed Code	Type	Input Range	Displayed Code
L	0.0 - 205.7°C	1815	L	32 - 1403°F	1820
L	32.0 - 402.2°F	1816	B	211 - 3315°F	1934
L	0 - 450°C	1817	B	100 - 1824°C	1938
L	32 - 841°F	1818	N	0 - 1399°C	5371
L	0 - 762°C	1819	N	32 - 2550°F	5324

Calibration: Complies with BS4937, NBS125 and IEC584.

Sensor Break Protection: Break detected within two seconds. Limit output set to OFF (Exceeded condition); alarms operate as if the process variable has gone over-range.

**Resistance Temperature Detector (RTD) and DC mV:** Ranges selectable from front panel (and displayed codes):

Input Range	Displayed Code	Input Range	Displayed Code
0 - 800°C *	7220	0.0 - 100.9°C	2295
32 - 1471°F	7221	32.0 - 213.6°F	2296
32 - 571°F	2229	-200 - 206°C	2297
-100.9 - 100.0°C	2230	-328 - 402°F	2298
-149.7 - 211.9°F	2231	-100.9 - 537.3°C	7222
0 - 300°C	2251	-149.7 - 999.1°F	7223

\* Default

Type and Connection: Three-wire Pt100

Calibration: Complies with BS1904 and DIN43760.

Lead Compensation: Automatic scheme.

RTD Sensor Current: 150 $\mu$ A (approximately)

Sensor Break Protection: Break detected within two seconds. Limit output set to OFF (Exceeded condition); alarms operate as if the process variable has gone over-range.

**DC Linear:** Ranges selectable from Front Panel (and codes displayed):

Input Range	Displayed Code	Input Range	Displayed Code
0 - 20mA	3413	0 - 5V	4445
4 - 20mA *	3414	1 - 5V	4434
0 - 50mV	4443	0 - 10V *	4446
10 - 50mV	4499	2 - 10V	4450

\* Default

(Changes may also be required to the CPU PCB link jumpers - see Volume II Subsection 2.5).

Scale Range Maximum:	-1999 to 9999. Decimal point as required.
Scale Range Minimum:	-1999 to 9999. Decimal point as for Scale Range Maximum.
Minimum Span:	1 display LSD.
Sensor Break Protection:	Applicable to 4 - 20mA, 1 - 5V and 2 - 10V ranges only. Break detected within two seconds. Limit output set to OFF (Exceeded condition); Alarms operate as if the process variable has gone under-range.

## A.2 REMOTE RESET INPUT (OPTION)

Type:	Voltage-free contact. Closure required for reset.
Maximum Contact Resistance (Logic 1):	50 $\Omega$
Minimum Contact Resistance (Logic 0):	500 $\Omega$
Maximum Input Delay (OFF-ON):	1 second
Minimum Input Delay (ON-OFF):	1 second

### A.3 LIMIT RELAY OUTPUT (OUTPUT 1)

Contact Type:	Single pole double throw (SPDT).
Rating:	5A resistive at 120/240V AC.
Lifetime:	> 100,000 operations at rated voltage/current.
Isolation:	Inherent.

### A.4 OUTPUT 2

Contact Type:	Single pole double throw (SPDT).
Rating:	2A resistive at 120/240V AC.
Lifetime:	> 500,000 operations at rated voltage/current.
Isolation:	Inherent.

### A.5 OUTPUT 3

#### General

Types Available:	Relay (Alarm or Annunciator output), DC linear (Recorder Output)
------------------	---

#### Relay

Contact Type:	Single pole double throw (SPDT).
Rating:	2A resistive at 120/240V AC.
Lifetime:	> 500,000 operations at rated voltage/current.
Isolation:	Inherent.

#### DC

Resolution:	Eight bits in 250mS (10 bits in 1 second typical, > 10 bits in > 1 second typical).
Update Rate:	4/second



Ranges:	0 - 20mA
	4 - 20mA
	0 - 10V
	0 - 5V

(Changes between V and mA require link jumper movement.)

Load Impedance:	0 - 20mA: 500 $\Omega$ maximum
	4 - 20mA: 500 $\Omega$ maximum
	0 - 10V: 500 $\Omega$ minimum
	0 - 5V: 500 $\Omega$ minimum
Isolation:	Isolated from all other inputs and outputs.
Range Selection Method:	Link jumper and front panel code.

## A.6 ALARM CONTROL

Maximum Number of Alarms:	Two "soft" alarms
Max. No. of Outputs Available:	Up to two outputs can be utilised for alarm purposes.
Combinatorial Alarms:	Logical OR or AND of alarms to an individual hardware output is available.

## A.7 COMMUNICATIONS

Type:	Serial asynchronous UART-to-UART link
Data Format:	One start bit, even parity, seven-bit data, one stop bit.
Physical Layer	RS485
Maximum Number of Zones:	32
Baud Rate:	Selectable from the front panel to be one of: 9600, 4800, 2400 or 1200 Baud.
Zone Address Selection:	From front panel (1 - 32)

## A.8 PERFORMANCE

### Reference Conditions

Generally as BS5558.

Ambient Temperature:	20°C±2°C
Relative Humidity:	60 - 70%
Supply Voltage:	90 - 264V AC 50Hz±1%
Source Resistance:	<10Ω for thermocouple input
Lead Resistance:	<0.1Ω/lead balanced (Pt100)

### Performance Under Reference Conditions

Common Mode Rejection:	>120dB at 50/60Hz giving negligible effect at up to 264V 50/60Hz.
Series Mode Rejection:	>500% of span (at 50/60Hz) causes negligible effect.

### DC Linear Inputs

Measurement Accuracy:	±0.25% of span (1LSD).
-----------------------	------------------------

### Thermocouple Inputs

Measurement Accuracy:	±0.25% of span ±1LSD. NOTE: Reduced performance with Type "B" Thermocouple between 100 - 600°C (212 - 1112°F).
Linearisation Accuracy:	Better than ±0.2°C any point, any 0.1°C range (±0.05°C typical). Better than ±0.5°C any point, any 1°C range.
Cold Junction Compensation:	Better than ±0.7°C.

### RTD Inputs

Measurement Accuracy:	±0.25% of span ±1LSD
Linearisation Accuracy:	Better than ±0.2°C any point, any 0.1°C range (±0.05°C typical). Better than ±0.5°C any point, any 1°C range.

## Recorder Output

Accuracy:  $\pm 0.25\%$  (mA @  $250\Omega$ , V @  $2k\Omega$ ); Degrades linearly to  $\pm 0.5\%$  for increasing burden (to specification limits).

## Operating Conditions

Ambient Temp. (Operating):  $0^{\circ}\text{C}$  to  $55^{\circ}\text{C}$

Ambient Temp. (Storage):  $-20^{\circ}\text{C}$  to  $80^{\circ}\text{C}$

Relative Humidity: 20% - 95% non-condensing

Supply Voltage: 90 - 264V AC 50/60Hz (standard)  
20 - 50V AC 50/60Hz or 22 - 65V DC (option)

Source Resistance:  $1000\Omega$  maximum (thermocouple)

Lead Resistance:  $50\Omega$  per lead maximum balanced (Pt100)

## Performance Under Operating Conditions

Temperature Stability: 0.01% of span/ $^{\circ}\text{C}$  change in ambient temperature.

Cold Junction Compensation (thermocouple Only): Better than  $\pm 1^{\circ}\text{C}$ .

Supply Voltage Influence: Negligible.

Relative Humidity Influence: Negligible

Sensor Resistance Influence: Thermocouple  $100\Omega$ :  $< 0.1\%$  of span error  
Thermocouple  $1000\Omega$ :  $< 0.5\%$  of span error  
RTD Pt100  $50\Omega/\text{lead}$ :  $< 0.5\%$  of span error

## A.9 ENVIRONMENTAL

Operating Conditions:	See <b>PERFORMANCE</b> .
EMI Susceptibility:	Designed to meet EN50082 Part 2. NOTE: For line-conducted disturbances induced by RF fields (10V 80% AM 1kHz), the product is self-recoverable in the frequency bands 17 - 47MHz and 68 - 80MHz.
EMI Emissions:	Designed to meet EN50081 Part 2.
Safety Considerations:	Designed to comply with IEC 1010-1 in as far as it is applicable.
Supply Voltage:	90 - 264V AC 50/60Hz (standard) 20 - 50V AC 50/60Hz or 22 - 65V DC (option)
Power Consumption:	4 watts approximately.
Front Panel Sealing:	Certified to IP65 (similar to NEMA 4).
Approvals:	Designed to meet FM approval.

## A.10 PHYSICAL

Dimensions:	Depth: 110mm ( $\frac{1}{16}$ -DIN), 100mm ( $\frac{1}{4}$ -DIN) Front Panel: W - 48mm, H - 48mm ( $\frac{1}{16}$ -DIN) W - 96mm, H - 96mm ( $\frac{1}{4}$ -DIN)
Mounting:	Plug-in with panel mounting fixing strap. Panel cut-out 45mm x 45mm ( $\frac{1}{16}$ -DIN) or 92mm x 92mm ( $\frac{1}{4}$ -DIN).
Terminals:	Screw type (combination head).
Weight:	0.21kg maximum ( $\frac{1}{4}$ -DIN and $\frac{1}{16}$ -DIN)

# ALPHABETIC INDEX

## A

AC/DC (24V) Supply		
Fuse rating	1-3	
Terminal connections	1-3	
Alarm 1 Type		
Selection of	3-4	
Alarm 2 Type		
Selection of	3-4	
Alarm Relay Output		
Relay rating	1-6, A-4	
Terminal connections	1-6	
Annunciator Relay Output		
Relay rating	1-6, A-4	
Terminal connections	1-6	

## C

Cold Junction Compensation		
Enabling/disabling	3-5	
Configuration Mode		
Automatic exit from	3-5	
Entry into	3-1	
Exit from	3-5	
CPU PCB		
Link jumpers	2-4	

## D

DC Output Option PCB		
Link jumpers	2-4	

## H

Hardware Definition Code		
Adjustment of	3-2	
Display of	3-2	
Input/Output Type selection	3-3	

## I

Input Range		
Selection of	3-4	
Input Ranges Available		
DC linear inputs	A-3	
RTD (Pt100) inputs	A-2	
Thermocouple inputs	A-1	
Input Type		
Selection of	2-4	

## L

Limit Action		
Selection of	3-4	
Limit Controller Dimensions		
1-1, A-8		
Limit Relay Output		
Relay rating	1-6, A-4	
Terminal connections	1-6	
Line Supply		
Fuse rating	1-3	
Terminal connections	1-3	
Voltage range	1-3	

## M

Mains Supply		
Fuse rating	1-3	
Terminal connections	1-3	
Voltage range	1-3	

## O

Output 2 Option PCB		
Removal/replacement	2-3	
Output 2 Usage		
Selection of	3-4	
Output 3 Option PCB		
Removal/replacement	2-3	

Output 3 Type	
Selection of	2-4
Output 3 Usage	
Selection of	3-5
<b>P</b>	
Panel-mounting	
Procedure	1-2
Panel-Mounting	
Cut-out dimensions (multiple installation)	1-1
Cut-out dimensions (single installation)	1-1
Maximum panel thickness	1-1
Procedure	1-1
PCB Positions	2-1
Power Consumption	1-3
<b>R</b>	
Rear Terminal Connections	1-3
Recorder Output	
Terminal connections	1-6
Remote Reset Input	
Terminal connections	1-6
Remote Reset Option PCB	
Indication of presence	3-3
Removal/replacement	2-3
Removing the Controller from its Housing	2-1
Replacing the Controller in its Housing	2-4
RS485 Communications Option PCB	
Indication of presence	3-3
RTD Input	
Terminal connections	1-6

**S**

Sensor Break	
Effect on outputs (DC linear inputs)	A-3
Effect on outputs (RTD inputs)	A-2
Effect on outputs (thermocouple inputs)	A-2
Serial Communications	
Address, selection of	3-5
Baud rate, selection of	3-5
Terminal connections	1-6
Serial Communications Option PCB	
Removal/replacement	2-3
Set Up Mode	
Lock code, display of	3-5

**T**

Thermocouple Input	
Terminal connections	1-3

**U**

Unpacking Procedure	1-1
---------------------	-----