

Mobrey

Magnetic Safety Switch

Type 30800 MK.4

Data sheet
SS1

The Mobrey Magnetic Safety Switch is an interlock switch recommended for use where a sealed switch is required. It is the responsibility of the user to carry out a suitable risk assessment exercise of the total safety system in accordance with BSEN954-1.

Function

The Solartron Mobrey safety switch is designed primarily for fitting to safety guards or access doors of electrically driven machines, wired in series with the stop/start button circuit it will prevent the machinery being started unless the safety guard is in position, and it will break the circuit if the guard is inadvertently opened while the machine is running. The safety switch may also be wired to an audible or visual alarm to indicate that a safety guard or access door is open.

Operation

When the guard is in position the actuating magnet must be located in the 'T' shaped recess of the fixed assembly. The two 'T' shaped magnets will repel each other through the wall of the fixed assembly to activate the SPDT changeover switch with a snap action.

The retaining magnet in the switch body provides a return force to reverse the changeover switch when the actuating magnet is withdrawn.

Advantages

The Solartron Mobrey safety switch is operated by a special 'T' shaped magnet designed to deter deliberate interference.

The magnetic transmission system eliminates the necessity for mechanical linkage between the safety guard and the switch; this feature is particularly advantageous where, for operating reasons the guard has to be completely removed.

The switch contacts (S.P.D.T. changeover) are moved in both directions entirely by magnetic forces and are not dependent upon springs or toggle arrangements.

The switch cover is secured by special lockshield screws to make it tamper

resistant. A special key provided with each switch permits access for installation and maintenance. The switch housing is proofed to allow hosing with hot water as required by food processing and other allied industries.

Features

- Deters deliberate interference
- No springs
- No mechanical linkages
- Magnetic transmission
- Dust proof
- Hose proof IP66
- Rugged
- Works in any position

Typical Applications

- Bacon slicers
- Bean slicing machines
- Bottle decrating and recrating machines
- Bread slicers and wrappers
- Confectionery wrapping machines
- Dough mixers and dividers
- Fish skinning machines
- Food wrapping machines
- Band saw change speed pulley access door
- Foundry sand batch mixers
- Guards on mills
- Bag and sack print machinery
- Gates and doors of rooms housing dangerous machinery or equipment
- Removable hoppers on filling machines
- Cake and pie making machines
- Strapping machines

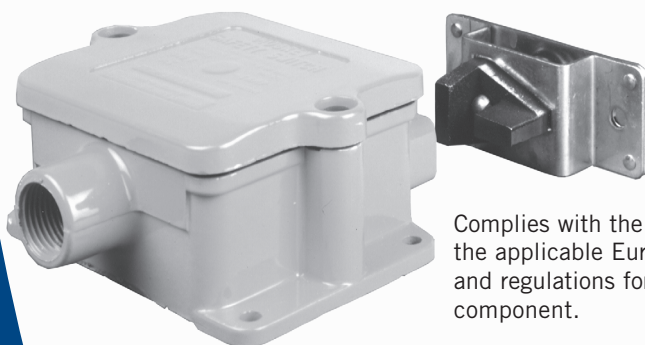

Complies with the requirements of the applicable European directives and regulations for a safety component.



Construction

The Solartron Mobrey safety switch has two main components :

Fixed Assembly

Comprises a die-cast aluminium housing containing the second 'T' shaped magnet, retaining magnet, switch contacts and terminals. The retaining magnet ensures that the contacts changeover with a positive action.

Actuating Assembly

This assembly is attached to the movable guard or door. The 'T' shaped permanent magnet is spring mounted in a bracket providing sufficient flexibility to allow for slight misalignment with the 'T' recess in the fixed assembly.

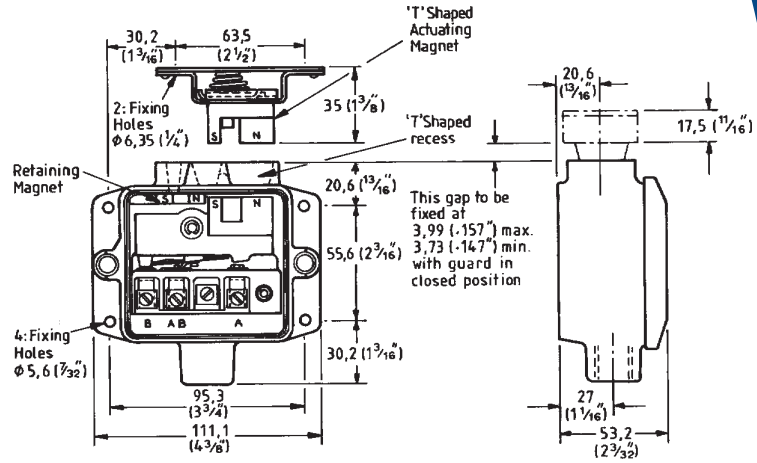

Specification

The Mobrey Magnetic Safety Switch is an interlock switch recommended for use where sealed switch is required. It is the responsibility of the user to carry out a suitable risk assessment exercise of the total safety system.

Electrical

The single-pole double throw changeover switch is of the air break type employing fine silver-faced contacts.

Connections

Terminals : A-AB closed with guard in place. In series with stop button.
Terminals : B-AB open with guard in place. May be used to operate 'guard open' warning light.

Conduit entry

Model 30800: M20 x 1.5 to B.S. 4568
Model U30800: 1/2" - 14 NPT
Model C30800: 1/2" - 14 NPT

Rating

Voltage	Rating	Rec. Fuse
240 V A.C.		
Non Inductive	480 V.A.	2A
440V A.C.		
Non Inductive	440 V.A.	1A
24 V D.C.	1 V.A.	1A

Rating : UL, CSA

240 V A.C.		
Non Inductive	360 V.A.	1A

If used as a cut-out for inductive circuits giving peak current in excess of the above the switch contacts should be connected through a suitable relay.

U.L. listed auxiliary device. For standard pilot duty B 300. Rating code as in U.L. 508. Enclosure Type 4.

Operating Characteristics

Ambient temp:
Maximum 60°C /140°F
Minimum 0°C / 32°F
Mounting :
The switch will operate in any position.
Weight: 0.91 kg / 2 lb

Spare Parts

Description	Part No.
Actuating magnet	
sub-assembly : 2 off	SK48
Cover gasket	SK49
Cover screw	
Cover screw key	SK96

Installation and Wiring

Mechanical

Mounting : the switch will operate in any position.

A suitable cable gland must be fitted to maintain the IP rating. The moving and fixed parts of the machinery guard must line up accurately at the point of closure in order to avoid damage to the 'T' shaped actuating magnet.

The dimension 0.157/0.147 (see diagram above) is of particular importance.

Actuating magnets attached to removable hoppers and guard should be positioned so as not to carry the weight of the hopper or guard when removed.

It is not intended as a guide for badly constructed or maintained guards.

If a pneumatic or hydraulic interlock bolt is incorporated in the guard mechanism, ensure the bolt can be correctly located before the A-AB contacts close.

IMPORTANT - PLEASE READ THOROUGHLY

Electrical : A fuse must be fitted in the supply line. Maximum rating as above.

Single Switch

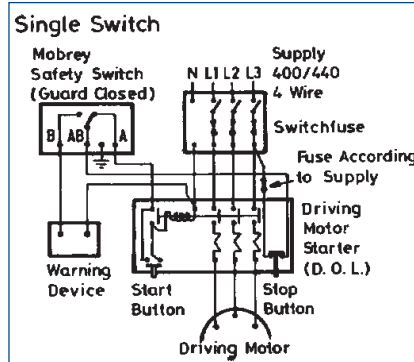

Multi - Switch

Solartron Mobrey magnetic safety switches may be wired in series, provided that any common 'guard open' indicator device is operated by the contacts of the motor starter or contactor. Alternatively, each safety switch should be wired to a dedicated 'guard open' indicator.

We do not recommend the use of a common indicating device wired in parallel with the switches. The switch contacts are not suitable for direct starting of motors.

Maintenance : Regular maintenance and inspection is essential

Particular care should be taken on a regular basis to ensure that the actuating magnet does not fail to locate as a result of inadequate maintenance of the moving guard or a build-up of dirt and debris from the process in the 'T' shaped slot on the switch body, and that the magnet is regularly checked to

ensure it is free from damage. If the fixed assembly is damaged or worn, it should be completely replaced and a new actuating magnet sub-assembly also fitted.

Solartron Mobrey Limited

Authorised distributor: **Ward Industries Limited**

Tel: +44 (0)1933 624963

Fax: +44 (0)1933 625458

Email: sales@wardindustries.co.uk

Web: www.wardindustries.co.uk

solartron
mobrey

a Roxboro Group Company



The right is reserved to amend details given in this publication without notice