

9700 Transmitter

Submersible hydrostatic level transmitter

Description

The 9700 series hydrostatic level transmitter is designed to perform in the most arduous conditions of today's level measurement applications.

Using temperature compensated, submersible or surface mount electronics with a ceramic capacitive sensor, the 9700 provides an accuracy of better than $\pm 0.1\%$ of calibrated span and excellent long term stability.

Mounting options enable simple installation in many applications from service tanks to remote reservoirs.

All transmitters can be mounted in areas subject to flooding and are rated IP68.

9700 transmitter

- Factory sealed and tested for submersed duty
- Good long-term stability

Features

- 2 wire 24V DC loop powered
- 4 to 20mA, remote zero and span option
- Accuracy $\pm 0.1\%$ of calibrated span
- Ranges up to 200m / 656ft H₂O
- 10:1 rangeability
- Ceramic capacitive sensor
- Low maintenance
- Fully submersible IP68 / NEMA 6P
- Reverse polarity protection
- Intrinsically safe option
- Dedicated marine version

Operation

At the heart of the 9700 is the Ceramic Capacitive pressure Sensor (CCS). The CCS provides a "flush" diaphragm, avoiding the risks of sensor clogging and ensures extremely low hysteresis, minimal output drift and high repeatability. With traditional sensors, process build up on the diaphragm face can result in an unreliable measurement, requiring regular servicing of the sensor.

For measurements up to 300 bar / 4350 psi, the series 9000 pressure transmitter offers a cost effective solution for most pressure measurement applications. The series 9000 also features a CCS and 0.1% accuracy.

For further information, ask for data sheet number IP0077.



mobrey

EMERSON[™]
Process Management

Product Overview

Simple installation, low maintenance

The 9700 is available in both submersible versions and externally mounted (floodable) versions. The housing contains the capacitive ceramic sensor and the electronics circuit board, all the components needed to produce an accurate and reliable measurement of the process. The glanding system used with the submersible versions ensures absolute integrity of the IP68 / NEMA 6P rating. IP68 / NEMA 6P units are generally factory fitted with the required length of vented cable fitted.

Protected from aggressive environments and processes

The transmitter is designed to withstand the harshest of environments. Its rugged, flush ceramic sensor is inherently capable of withstanding attack from most chemicals.

Mounting options

The 9700 is available in various mounting configurations, all are rated IP68.

- 9710 - Cable suspended
- 9720 - Clamped, cable suspended
- 9780 - Pole mounted
- 9790 - Flanged
- Threaded mounting is available upon request

Typical installation

In order to simplify installation, all 9700 series transmitters can be supplied with remote zero and span.

Remote zero and span allows zero and full scale output to be set without removing sensor from process, this option includes an IP67 junction box.

Bellows

For humid environments or sea water applications bellows must be selected. (Option 4 of zero and span)

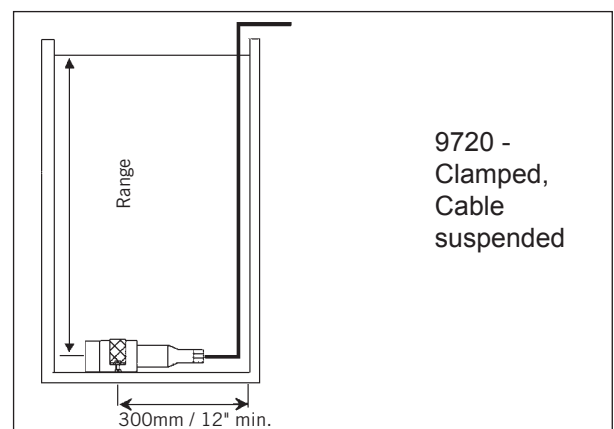
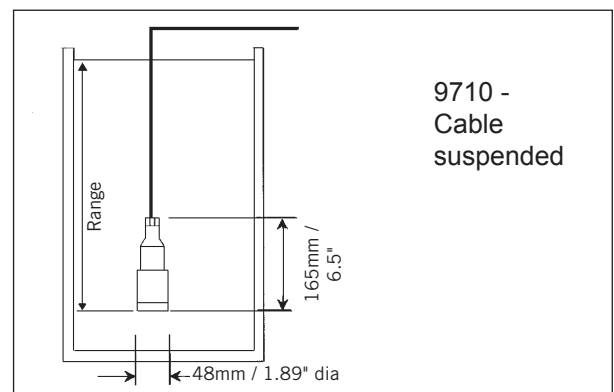
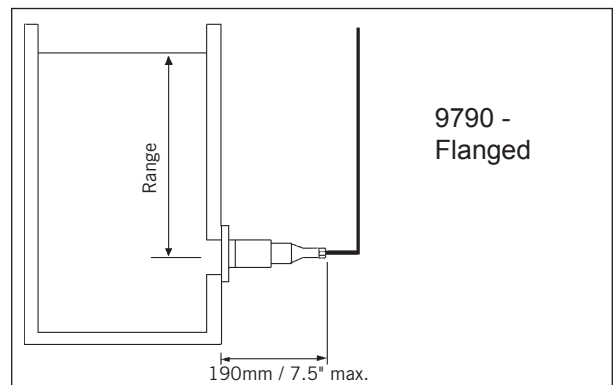
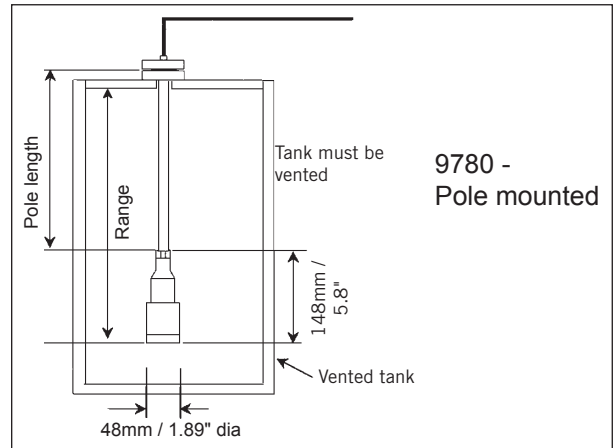
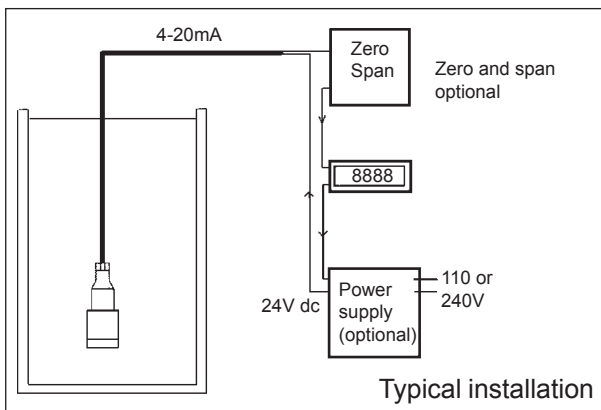

Approvals

See back page

Ordering information : Commercial version

97	9700 Series, electronic hydrostatic level transmitter - Commercial version									
	Code	Sensor type								
	10C	Cable suspended, submersible								
	20C	Clamped, cable suspended, submersible								
	80C	Pole mount, submersible								
	90C	Flanged, submersible								
	Code	Enclosure and process connection material								
	S	Stainless steel 316								
	A	Aluminum bronze								
	Code	'O' ring material								
	1	Fluorocarbon (FPM/FKM)								
	2	Nitrile								
	Code	Nominal range								
	A	0 to 2m / 6.56ft H ₂ O								
	B	0 to 5m / 16.4ft H ₂ O								
	C	0 to 10m / 32.8ft H ₂ O								
	D	0 to 20m / 65.62ft H ₂ O								
	E	0 to 50m / 164ft H ₂ O								
	F	0 to 100m / 328ft H ₂ O								
	G	0 to 1m / 3.3ft H ₂ O								
	H	0 to 3.5m / 11.5ft H ₂ O								
	J	0 to 200m / 656ft H ₂ O								
	Code	Zero and span								
	1	Integral (Fixed)								
	2	Remote								
	4	Remote + bellows								
	Code	Cable material <i>(See Note 1 and Note 2)</i>								
	P	Polyurethane Specify cable length with order								
	F	Fluorinated ethylene-propylene (F.E.P) Specify cable length with order								
	X	None								
	Code	Approval								
	0	Non certified - Safe area use only								
	1	ATEX II 1 GD , EEx ia IIB T4 <i>(See Note 3)</i>								
	2	CSA (Canada & USA)								
	3	ATEX II 1G EEx ia IIB T4								
	Code	Process connection								
	A	Slip-on flange DN25 PN40 (DIN 2635)								<i>not 9780</i>
	B	Fixed flange DN40 PN40 (DIN 2635)								
	C	Fixed flange DN50 PN40 (DIN 2635)								
	D	Fixed flange DN80 PN40 (DIN 2635)								
	E	Slip-on flange 1" # 150 ANSI B16.5								<i>not 9780</i>
	F	Fixed flange 2" # 150 ANSI B16.5								
	G	Fixed flange 3" # 150 ANSI B16.5								
	X	None								
	Code	Pole								
	0	Pole without joints }								
	1	Pole with 1 joint }								Specify pole length with order
	2	Pole with 2 joints }								
	3	Pole with 3 joints }								<i>See Note 1 & Note 4</i>
	4	Pole with 4 joints }								
	9	No pole								
97	10C	S	1	A	1	P	0	X	9	Typical ordering code

Note 1 : Specified cable and pole length is from transmitter enclosure

Note 2 : Maximum permissible cable length is 220m.

Note 3 : Approval Code 1 - ATEX II 1 GD EEx ia IIB T4 - is NOT a standard option but is available as a special.

Note 4 : For pole lengths over 2m, pole is divided into equal length using pole joints.

Maximum number of poles for assembly is 4 off with a maximum length of 2m per pole.

Ordering information : Marine version

97	9700M	Series, electronic hydrostatic level transmitter - Marine approved version								
	Code	Electronics enclosure and process connection material								
	10M	Cable suspended, submersible								
	20M	Clamped, cable suspended, submersible								
	80M	Pole mount, submersible								
	90M	Flanged, submersible								
	Code	Electronics enclosure and process connection material								
	S	Stainless steel 316 - for non sea water applications <i>(See Note 1)</i>								
	A	Aluminium bronze - for water and sea water applications <i>(See Note 2)</i>								
	Code	'O' ring material								
	1	Fluorocarbon (FPM/FKM)								
	2	Nitrile								
	Code	Nominal range								
	A	0 to 2m / 6.56ft H ₂ O								
	B	0 to 5m / 16.4ft H ₂ O								
	C	0 to 10m / 32.8ft H ₂ O								
	D	0 to 20m / 65.62ft H ₂ O								
	E	0 to 50m / 164ft H ₂ O								
	F	0 to 100m / 328ft H ₂ O								
	G	0 to 1m / 3.3ft H ₂ O								
	H	0 to 3.5m / 11.5ft H ₂ O								
	J	0 to 200m / 656ft H ₂ O								
	Code	Zero and span								
	1	Integral (Fixed) <i>(See Note 1)</i>								
	2	Remote <i>(See Note 1)</i>								
	4	Remote + bellows								
	Code	Cable material <i>(See Note 3 and Note 4)</i>								
	P	Polyurethane Specify cable length with order								
	F	Fluorinated ethylene-propylene (F.E.P) Specify cable length with order								
	X	None								
	Code	Electrical approval								
	0	Non certified - safe area use only								
	1	ATEX II 1GD, EEx ia IIB T4 <i>(See Note 5)</i>								
	2	CSA (Canada & USA)								
	3	ATEX II 1G EEx ia IIB T4								
	Code	Process connection								
	A	Slip-on flange DN25 PN40 (DIN 2635) <i>not 9780</i>								
	B	Fixed flange DN40 PN40 (DIN 2635)								
	C	Fixed flange DN50 PN40 (DIN 2635)								
	D	Fixed flange DN80 PN40 (DIN 2635)								
	E	Slip-on flange 1" # 150 ANSI B16.5 <i>not 9780</i>								
	F	Fixed flange 2" # 150 ANSI B16.5								
	G	Fixed flange 3" # 150 ANSI B16.5								
	X	None								
	Code	Pole								
	0	Pole without joints }								
	1	Pole with 1 joint } Specify pole length								
	2	Pole with 2 joints } with order								
	3	Pole with 3 joints } <i>(See Note 3 and Note 6)</i>								
	4	Pole with 4 joints }								
	9	No pole								
97	10M	S	1	A	1	P	0	X	9	Typical ordering code

Note 1 : Do not specify for sea water applications

Note 2 : For use with water and sea water applications, remote and bellows (Option 4 zero and span) must be selected.

Note 3 : Specified cable and pole length is from transmitter enclosure

Note 4 : Maximum permissible cable length is 220m.

Note 5 : Approved Code 1 - ATEX II 1GD EEx ia IIB T4 - is NOT a standard option but is available as a special.

Note 6 : For pole lengths over 2m, pole is divided into equal length using pole joints.

Maximum number of poles for assembly is 4 off with a maximum length of 2m per pole.

Specification

Functional

9710, 9720, 9780, 9790	
Output signal	Two-wire, 4-20mA
Power supply	10 to 30 Vdc
Load resistance	R=50 x (supply voltage-10V) Ω
Measuring range	Up to 200m / 8" to 656ft H ₂ O (see note)
Ovrange limit	5 x range up to a max 600m / 1968ft H ₂ O
Span adjustment	+10 to + 100% URL*
Process temp. limits	
9710, 9720 & 9780	-20 to + 60°C / -4 to +140°F
9790	-20 to + 90°C (80°C Ex ia)
Ambient temp. limits	-20 to + 90°C (-20 to +80°C Ex ia)
Humidity limits	0 to 100% RH***
Hazardous area certification	ATEX II 1 G EEx ia IIB T4 CSA (Canada & USA)

Note *** : When terminated using the 9710/077 vented terminal box

Performance

9710, 9720, 9780, 9790	
Accuracy:	+/- 0.1% ** of calibrated span
Stability:	+/- 0.1% URL* per 6 months
Temperature effect: (over ambient temp. range)	+/-0.015% URL per °C / °F

Physical

9710, 9720, 9780, 9790	
Cable entry	Glanding system supplied with required length of vented cable
Wetted Parts	
<i>Sensor</i>	Ceramic
<i>Sensor housing</i>	316 Stainless steel, Aluminium bronze
<i>Seal rings</i>	Fluorocarbon (FPM/FKM), Nitrile
<i>Cable</i>	Polyurethane Flourinated Ethylene Polypropylene (FEP)
Pole	316 Stainless Steel pole supplied with 316 Stainless Steel Housing option Copper Nickel pole supplied Aluminium Bronze Housing option
Ingress protection:	IP68 / NEMA 6P (200m / 656ft H ₂ O)
Approximate weight:	0.7Kg / 1.54lbs (sensor only)
Remote Enclosure:	Aluminium alloy IP67 Grey (RAL 7001) 0.7 kg
Bellows Enclosure:	Polyester IP67 Grey (RAL 7001) 1.2 kg

* URL = Upper range limit ** includes effects of linearity, hysteresis and repeatability

Level

Approvals

Hazardous Area Certification :
ATEX II 1 G
ATEX II 1 GD (available upon request)
EEx ia IIB T4 Intrinsically Safe
CSA (Canada & USA)
CLI, DIV1, GPS C & D
CL II DIV1, GPS E, F & G, CL III
Ex ia IIB T4
AEx ia IIB T4

Marine Approvals :
Lloyds Register
Bureau Veritas
American Bureau of Shipping
Korean Register
Germanischer Lloyd
DNV

Mobrey Measurement Limited
Authorised distributor: Ward Industries Limited
Tel: +44 (0) 1933 624963 Fax: +44 (0) 1933 625458
E-mail: sales@wardindustries.co.uk Web: www.wardindustries.co.uk

The Emerson logo is a trade mark and service mark of Emerson Electric Co.
Mobrey is a registered trademark of Mobrey Ltd.
All other marks are the property of their respective owners
We reserve the right to modify or improve the designs or specifications of product and services at any time without notice.

International:

Emerson Process Management
Mobrey Measurement
158 Edinburgh Avenue,
Slough, Berks, SL1 4UE, UK
T +44 1753 756600
F +44 1753 823589
www.mobrey.com