

# SM1000

## Videographic recorder

### Simplicity without compromise



#### Clear display of process information

- bright TFT display

#### Robust and convenient archive storage

- low cost, high reliability, Compact Flash option
- high capacity

#### Secure data recording

- internal Flash memory for 12 recording channels and logs
- no battery back-up required

#### 21 CFR Part II compliant data security

- extensive physical and electronic security features

#### Intuitive user interface

- dedicated tactile operator keys and Microsoft® Windows-style menus

#### Unsurpassed environmental protection

- hosedown to IP66 and NEMA4X standards

#### 10BaseT Ethernet communications

- remote monitoring/access
- email notification of alarms and status report

#### GAMP validation package

- 21 CFR part 11 compliant

**SM1000**

The SM1000 is a state-of-the-art solution to recording and data storage. It provides 12 recording channels and up to 12 universal analog inputs which can be viewed in a variety of display formats: chart, bargraph, digital indicator and process summary. Historical logs are provided for recording alarms, operator and system events and totalizer values

The SM1000 has onboard Flash memory for secure storage of process data. Process data can also be logged to a Compact Flash card, then transferred to a PC for storage and analysis

**Application areas include:**

- Water treatment plants
- Cold storage
- Stack gas monitoring
- Environmental monitoring
- Autoclaves
- Food, Dairy and Beverage processing
- Furnaces
- Heat treatment
- Pulp & Paper
- Life sciences

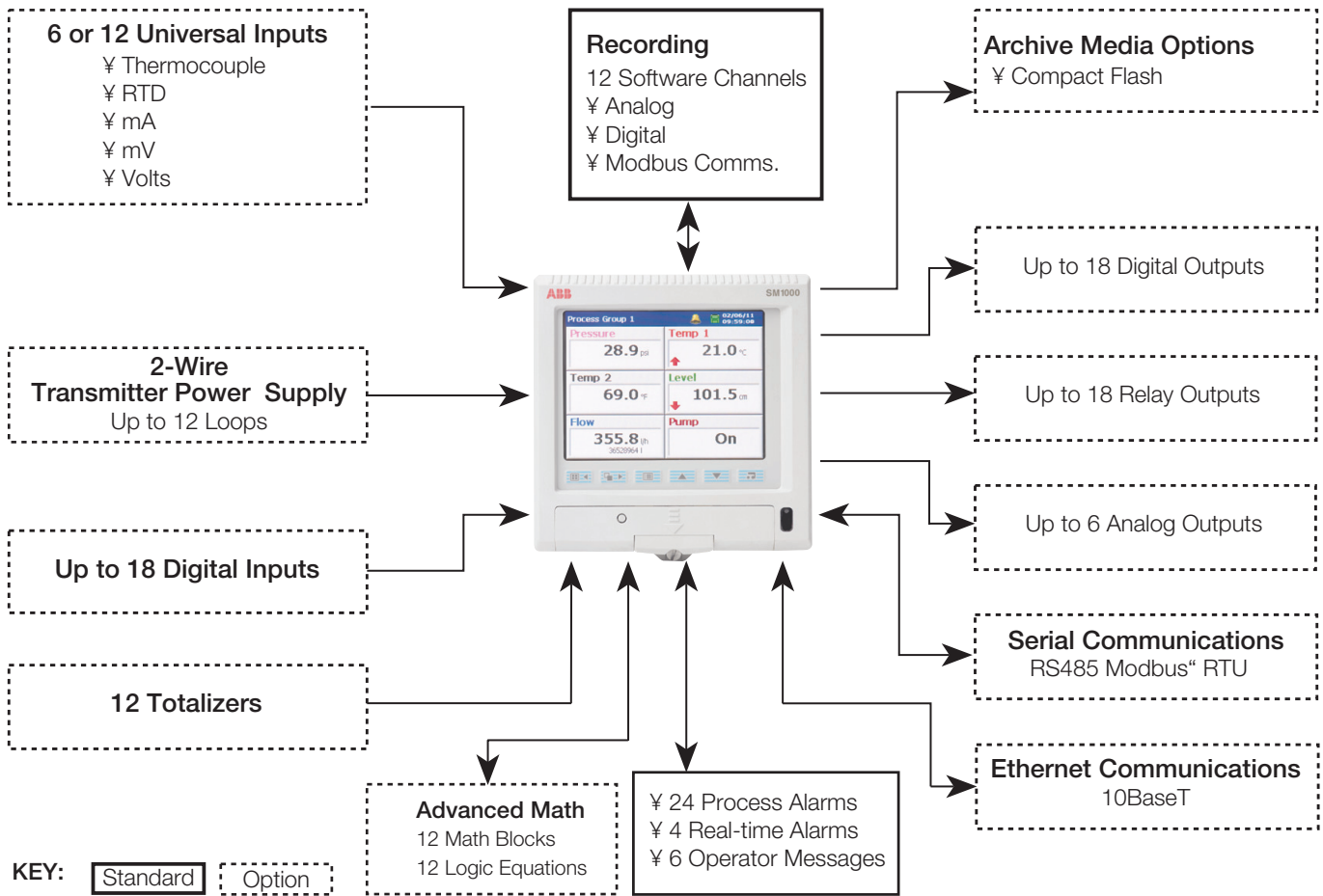

## Simplicity of Use

- Six dedicated tactile keys are used for all aspects of operation and configuration of the SM1000.
- During everyday operation each key has a specific function ensuring simplicity of use.
- The use of a Windows-style pop-up menu and configuration screens ensures that the operation of the SM1000 is exceptionally easy and instantly familiar.

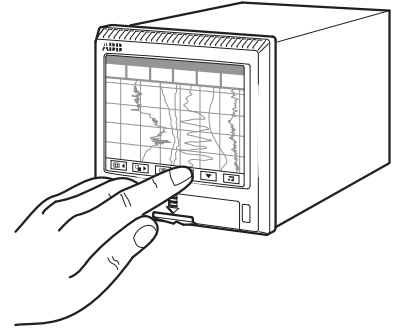

## Guaranteed Data Integrity

- The use of Flash memory technology ensures that the SM1000 is not reliant on batteries to preserve stored data during a power failure.
- In the internal memory, data is stored in small blocks with each block containing a checksum to ensure the integrity of that data.
- Internal flash memory is provided for buffering of process data. At any time the complete memory can be reviewed in the Chart View of the SM1000. Once this memory is full it automatically wraps-around and overwrites the oldest data, ensuring that the latest process data is always captured.
- 12 recording channels are provided, as standard, which can be used to record any analog, digital or communications (via Modbus™) signal. Two sample rates can be pre-set in the configuration of the SM1000; a primary and a secondary (fast or slow). Automatic switching between these two sample rates allows detailed information to be stored under specific process conditions, for example, critical process states or alarm conditions. Through the use of pre-storage filters it is possible to record the average, max./min. or instantaneous value of any analog data.

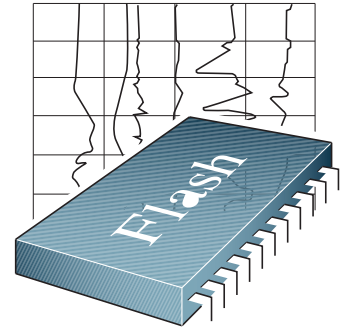

## Industrial Standard, Robust, Archive Storage

- Compact Flash memory cards can be used for archiving purposes. The solid state nature of these cards ensures that the SM1000 can truly operate in ambient temperatures up to 50 °C (122 °F).
- Every write to the archive storage media is verified to ensure the integrity of the data.
- Process data can be archived to the removable media in either of two configurable formats, comma separated variable or binary encoded. In addition to the analog/digital recording channels, the alarm event, totalizer (if fitted) and audit logs can also be archived to the removable media.
- Security of all process data stored to the memory card is always ensured. Files stored in comma separated variable format are attributed with an Encrypted Digital Signature and files stored in binary format are securely encoded with inbuilt integrity checks. Both formats of data storage are compliant with FDA standard 21 CFR Part II.
- A Media door lock is fitted as standard to prevent unauthorized access to the removable media.



## 21 CFR part 11 Compliance and GAMP Validation Package

With its comprehensive audit trail, secure archiving format and extensive physical and configuration security features, the SM1000 is ideally suited to applications where compliance to 21CFR part 11 (the FDA's regulations regarding electronic record keeping) is required (for further information refer to [INF02/70](#)).

In keeping with this, a template for validating the SM1000 videographic recorder is available. Following GAMP 5 (a risk-based approach to compliant GxP computerized systems), the template is designed to make the validation process as simple as possible and provides an IQ and OQ that is completed at the customer site, before and after installation. Once completed, the template is then packaged together with other documentation relating to the system as a whole, ready to be presented to the governing regulatory body for inspection.

### Low Cost of Ownership

The large capacity of the storage media used on the SM1000 ensures that the requirement for operator intervention to transfer the data to a PC on a regular basis is greatly reduced.

See below for an example of how memory storage times vary depending on the media device. The example shows the recording duration for a 6-channel recorder with a sample time of 10 s configured to use binary archiving. Also included in the example is how these storage times compare with a traditional paper recorder.

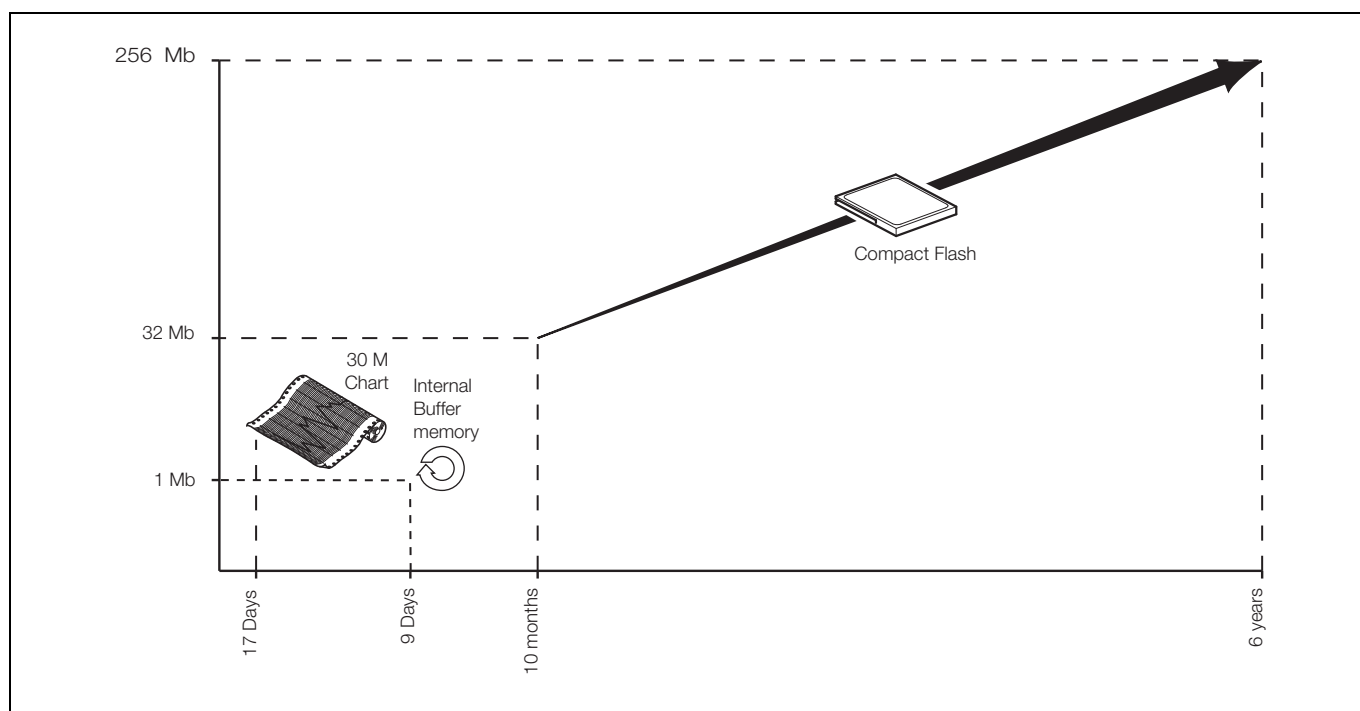

### Unsurpassed Environmental Protection

Unique to this type of product, the SM1000 has unrivalled protection ratings of IP66 and NEMA4X and includes a fully-sealed, lockable media door. This enables the SM1000 to be installed, without additional protection, in applications that require frequent hosedown. With industrial standard noise emission and immunity protection, the SM1000 operates effectively in high electrical-noise environments.

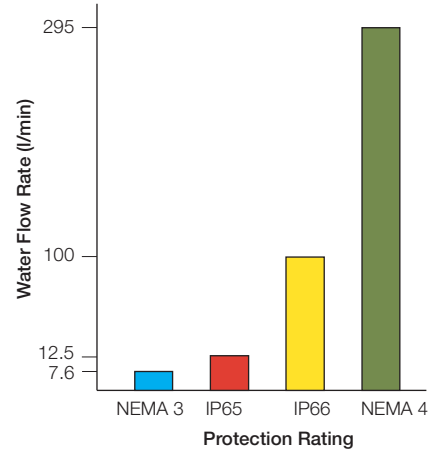

### Intuitive User Interface

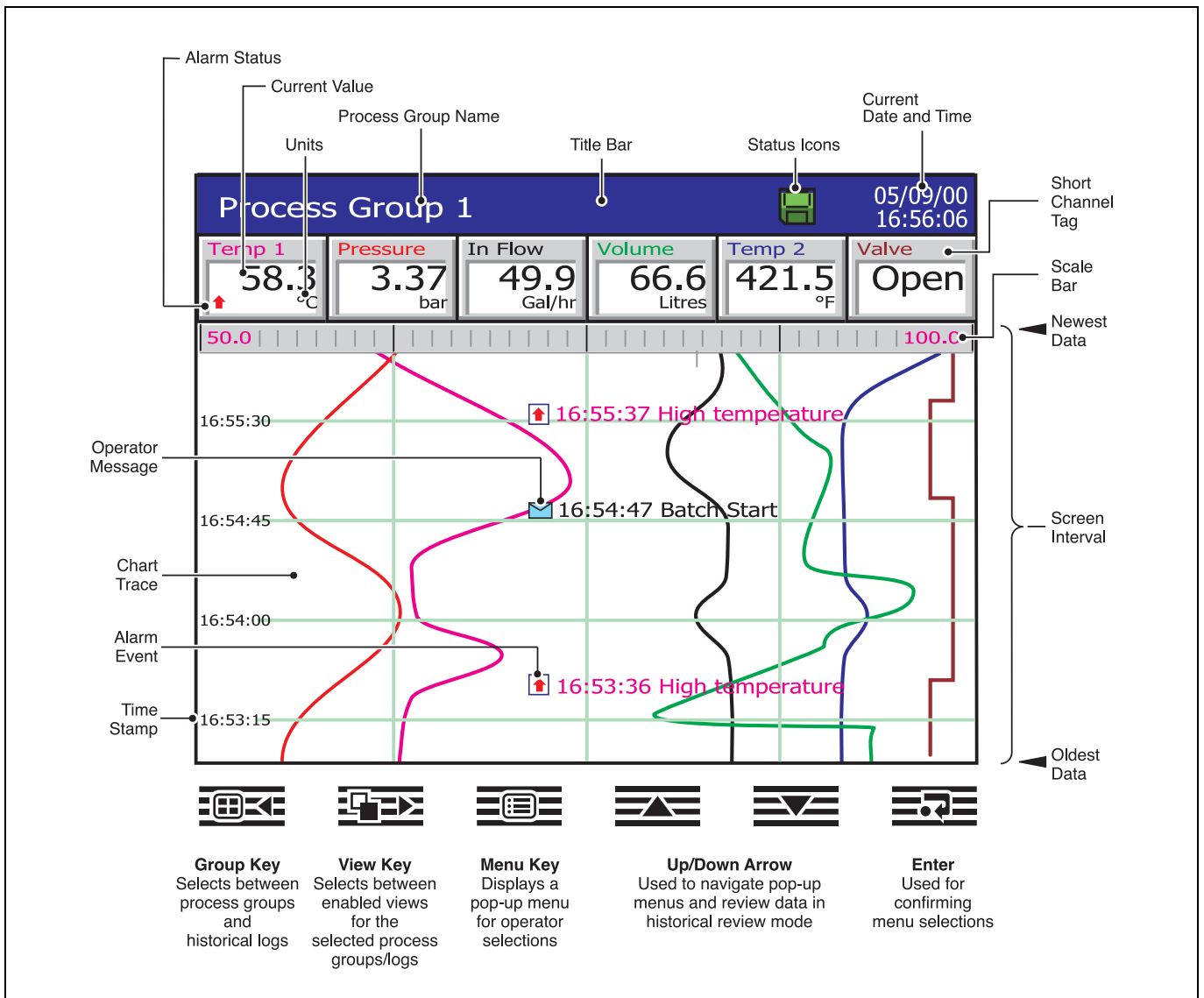

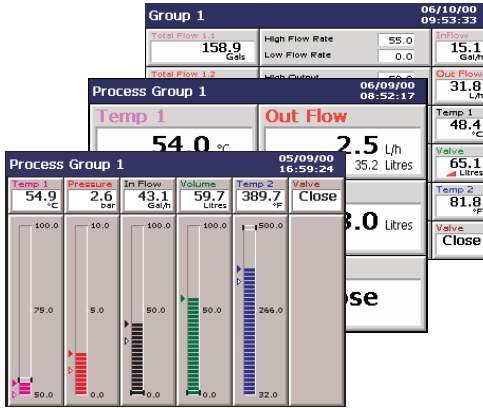

## Operator Views

In addition to the standard chart view, a number of other operator views are available:

- **Process View**

Provides an at-a-glance summary of each channel including alarm, totalizer and statistical (max./min.) information.

- **Digital Indicator View**

Process value, engineering units, channel tag, associated totalizer (if fitted), and alarm status are all shown. Auto-sizing always ensures the clearest possible display.

- **Bargraph View**

Horizontal or vertical format which includes min./max. and alarm trip point markers.

Totalizer Log				
No	Tag/Value	Source Tag	Date	Time
42	Total Flow 1.1 0.0 Litres	I/P A1	16/10/00	09:26:20
43	Total Flow 1.2 0.0 Litres	I/P A2	16/10/00	09:26:20
44	Total Flow 1.3 0.0 Litres	I/P A3	16/10/00	09:26:20
45	Total Flow 1.4 0.0 Litres	I/P A4	16/10/00	09:26:20

Alarm Event Log				
No	Event Tag	Source Tag	Date	Time
36	Max Capacity	Volume	06/09/00	09:03:04
37	High temperature	Temp 1	06/09/00	09:03:16
38	High temperature	Temp 2	06/09/00	09:03:16
39	High temperature	Temp 3	06/09/00	09:03:16
40	High temperature	Temp 4	06/09/00	09:03:16
41	Max Cap	Volume	06/09/00	09:03:16
42	Max Cap	Volume	06/09/00	09:03:16
43	Min Cap	Volume	06/09/00	09:03:16
44	High ten	Volume	06/09/00	09:03:16
45	Max Cap	Volume	06/09/00	09:03:16
46	Min Cap	Volume	06/09/00	09:03:16
47	Max Cap	Volume	06/09/00	09:03:16

Audit Log				
No	Event/Tag	OP ID	Date	Time
00	Config Changed	Oper 2	05/10/00	12:43:20
01	Power failure		05/10/00	12:43:39
02	Touch Screen Calib		05/10/00	12:43:39
03	Power Recovery		05/10/00	12:43:39
04	Media Read Error		05/10/00	12:44:18
05	File Created		05/10/00	12:45:18
06	Config Changed	Oper 4	05/10/00	12:45:31

## Historical Logs

Providing functions unavailable in paper-based recorders, three historical logs ensure complete validity of the recorder and its data. Any or all of these logs can be exported to the removable media:

- **Alarm Event Log**

Complete display of all acknowledged and unacknowledged alarms, alarm state changes and operator messages.

- **Audit Log**

Displays time, date and ID stamped system data including configuration, calibration changes, system errors and operation actions. This provides comprehensive evidence of the integrity, validity and traceability of the SM1000 and its measured data in accordance with FDA guidelines 21 CFR part 11.

- **Totalizer Log**

Independent log intervals for each channel, enabling total, average, maximum and minimum readings to be time and date stamped.

Channel 1.1 Configuration Screen:

- Setup: Analog I/P A1, Alarm A, Alarm B, Totalizer
- Input type: 4.0 - 20.0 mA
- Engineering range: 0.0 - 100.0 %
- Tag: SM1000
- Filter time constant: [ ]
- Fault detect level: [ ]
- Broken sensor direction: [ ]

Tag Input Keypad:

1	2	3	4	5	6	7	8	9	0
A	B	C	D	E	F	G	H	I	J
K	L	M	N	O	P	Q	R	S	T
Del	U	V	W	X	Y	Z			
OK -->abc..									

## Configuration

A simple Windows-style structure provides an exceptionally simple approach to the set up of the recorder. Text and numerical information is very quickly entered via an on-screen keyboard. Navigation of the configuration menus is performed via the cursor keys and the pop-up menu.

The configuration mode is protected via a user-specific password system. All configuration changes are logged in the Audit log complete with operator ID's.

It is also possible to configure the SM1000 with a Windows-based PC configuration package.

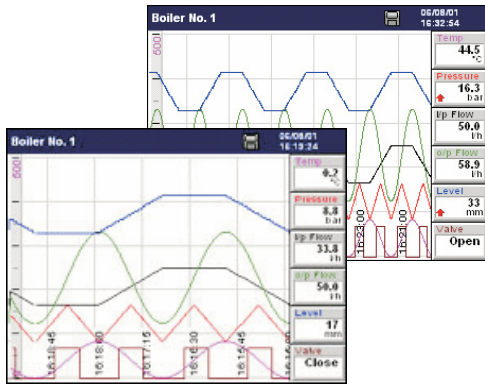

## On-line Data Review

The SM1000 provides a number of unique features to provide a clear view of your process

- The screen interval can be altered to display between 18s and 7 days of information, without it affecting the sample rate. This gives you the ability to 'zoom in' to a close-up view of the most current data or 'zoom out' and get the big picture.
- Individual traces can be removed temporarily from the screen to enable clear comparison of two or more channels.
- The instrument can easily review all historical data in the internal buffer memory at the touch of a button. During this time, recording of the process data to the internal memory remains unaffected.

## Off-Line Review and Analysis

Using ABB's DataManager Pro software, archived process data and historical logs recorded to a removable media card can be easily reviewed.

- Database management of data files provided by DataManager Pro ensures simple, secure long-term storage and retrieval of historical data.
- The graphing capabilities provided by DataManager Pro ensure easy interrogation of process data.
- The validity of all data files is always checked by DataManager Pro during the storage and retrieval process, ensuring maximum data integrity.

For further information on the capabilities of DataManager Pro, refer to data sheet DS/RDM500-EN.

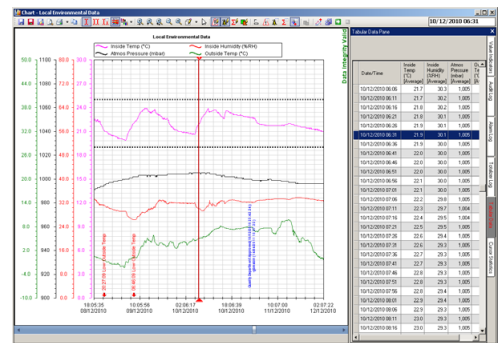

## Batch Recording

A batch recording option enables simple recording and reviewing of batch processes. When a batch is started it is tagged with a unique batch number, operator identification and three user-definable description fields. All information is entered on-screen with a history function allowing quick entry of commonly repeated descriptions.

Using DataManager Pro software batches can be simply and quickly traced for review using the unique batch number and description information entered at the time of recording. Additional functionality provides the ability to search and sort batch records for an entire production facility in many ways, including by product type, operator and time and date of processing.

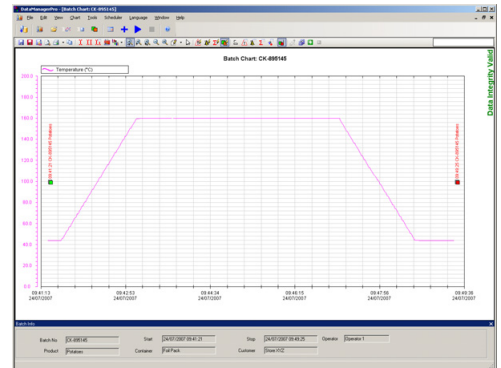



## Math and Logic

Available as an option are advanced math and logic capabilities. 12 multi-element math and 12 multi-element logic equations can be programmed via the touch screen of the recorder. Equations can be nested in to each other to provide extensive capabilities.

- Mean, standard deviation and rolling averaging functions are provided.
- Standard addition, subtraction, multiplication and division are complemented with Log, Ln, Square root, power, Sin, Cos, Tan and absolute functions.
- Switching of process signals can be achieved via the high/low/mid signal selection and multiplexing functions.
- Predefined equations are provided for relative humidity and FO calculations.
- AND, NAND, OR, NOR, XOR and NOT operators are available within the logic equations.

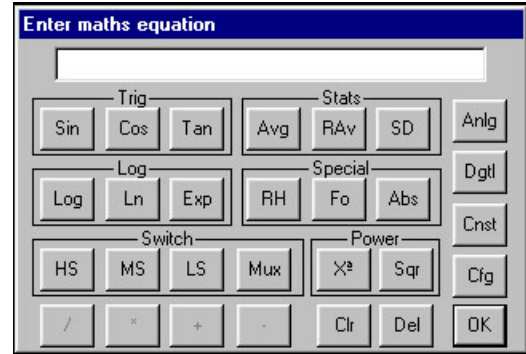

All math and logic equation results can be recorded on the display of the recorder and archived to removable media. Detailed diagnostic functions are provided for both the math and logic equations.

## Ethernet Communications

The SM1000 can provide 10BaseT Ethernet communications via a standard RJ45 connector and uses industry-standard protocols TCP/IP, FTP and HTTP. The use of standard protocols enables easy connection into existing PC networks.

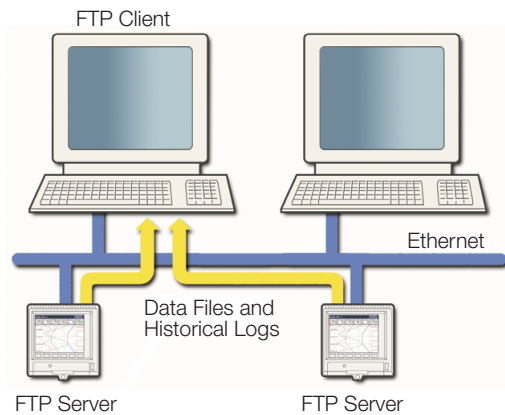

### Data File Access via FTP (File Transfer Protocol)

The SM1000 features FTP server functionality. This functionality provides high-speed access via Ethernet to data archived by the recorder.

- Using a standard web-browser or other FTP clients, data files contained within the SM1000's internal memory and memory card can be accessed remotely and transferred to a PC or network drive.
- Four individual FTP users can be programmed into the SM1000. Access rights can be configured for each user specifying their access level.
- All FTP log-on activity is recorded in the audit log of the SM1000.
- Using ABB's data file transfer scheduler program, data files from multiple recorders can be automatically backed-up to a PC or network drive for long term storage ensuring the security of valuable process data and minimizing the operator intervention required.



### Embedded Web Server

Contained within the SM1000 is an embedded web-server allowing access to web pages created within the recorder. The use of HTTP (Hyper Text Transfer Protocol) enables standard web browsers to view these pages.

- Detailed with the web pages is the current display of the recorder, detailed information on process signals, alarm conditions, totalizer values and other key process information.
- The historical logs stored in the SM1000's internal buffer memory can be displayed in full from within the web pages.
- Operator messages can be entered via the web server enabling comments to be logged to the recorder.
- All of the information displayed on the web pages is regularly refreshed enabling them to be used as a process supervision tool.

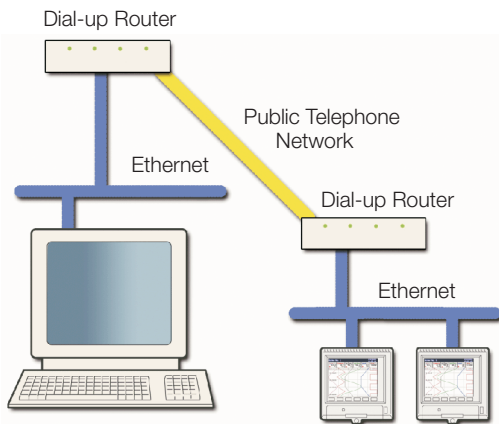
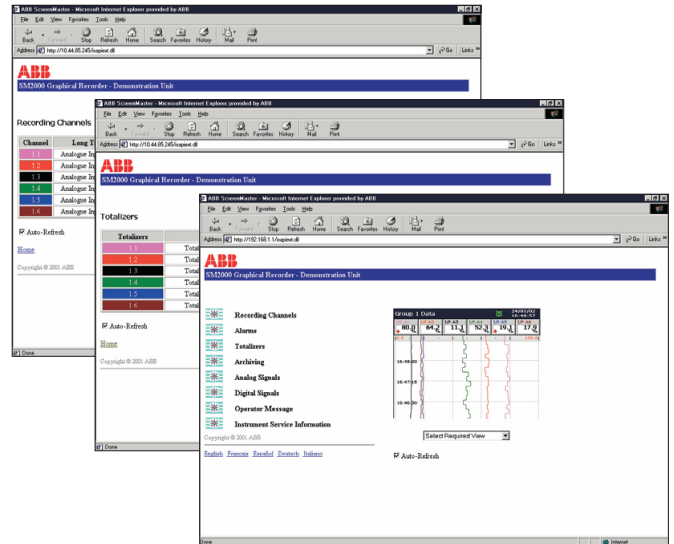

### On-line Demonstration

A demonstration of these features is available from an on-line recorder accessible via the internet. In the address bar of your web browser enter '<http://217.46.239.73>'.

### Remote Access/Monitoring

Ethernet communications can provide a link to recorders installed in remote locations. Via the use of a dial-up router an SM1000 can be installed in a remote location and accessed via a public telephone network when required.

### Email Notification

Via the SM1000's inbuilt SMTP client the recorder is able to email notification of important events. Emails triggered from process alarms or other critical process events can be sent to multiple recipients. The recorder can also be programmed to email reports of the current process status at specific times during the day, the content of which can be tailored to suit your specific process needs.

## SM1000

Videographic recorder

## Specification

### Operation and Configuration

#### Configuration

Via tactile membrane switches on front panel or PC Configuration

Multiple configuration files can be stored in internal (up to 16 files) or external memory (with removable media option fitted)

#### Configuration ports

3.5 mm jack socket for connection to RS232 port on a PC via an adapter

#### Display

Color, TFT, liquid crystal display (LCD) with built-in backlight and contrast adjustment

125 mm (5 in.) diagonal display area, 76800 pixel display\*

**\*Note.** A small percentage of the display pixels may be either constantly active or inactive. Max. percentage of inoperative pixels < 0.01 %

#### Language

English, German, French, Italian and Spanish

#### Dedicated operator keys

- Group select/left cursor
- View select/right cursor
- Menu key
- Up/Increment key
- Down/Decrement key
- Enter key

#### Chart screen intervals

Selectable from 18 s to 7 days

#### Chart divisions

Programmable for up to 10 major and 10 minor divisions

#### Chart annotation

Alarm and operator messages may be annotated on the chart

Icons to identify the type of event, time of occurrence and tag are displayed

## Security

### Physical

Standard door lock

### Configuration security

Password protection	Access to configuration is allowed only after the user has entered a password
Internal switch protection	Access to configuration is allowed only after a hardware switch has been set. This switch is situated behind a tamper-evident seal

### Logging security

Configuration	Can be configured for password protection or free access to logging levels
---------------	--

### Basic type security

4 individual users with unique username and passwords

### Advanced type security

Number of users	Up to 12
Usernames	Up to 20 characters, Usernames are unique (names cannot be repeated)
Access privileges	Logging access — Yes/No Configuration access None/load file only/limited/full
Passwords	Up to 20 characters A minimum required password length of 4 to 20 characters can be configured and a password expiry time can be applied to eliminate password ageing
Password failure limit	Configurable for 1 to 10 consecutive occasions or 'infinite' A user is deactivated if a wrong password is entered repeatedly
Deactivation of inactive users	Can be disabled or configured for 7, 14, 30, 60, 90, 180 or 360 days of inactivity Users are deactivated (by removal of access privileges) after a period of inactivity

## Operator Views

Contents	Views Available			
	Chart	Bargraph	Digital Indicator	Process*
Instantaneous values/states	✓	✓	✓	✓
Units of measure	✓	✓	✓	✓
Short tags	✓	✓	✓	✓
Long tags	—	—	—	✓
Alarm status	✓	✓	✓	✓
Alarm trip markers	—	✓	—	—
Alarm trip values	—	—	—	✓
Max./Min. markers	—	✓	—	—
Analog bargraphs	—	✓	—	—
Totalizer values & units of measure	—	—	✓	✓
Totalizer tags	—	—	—	✓
Max., min. and average batch values	—	—	—	✓
Graphical view of historical data	✓	—	—	—

\* If Totalizer option is fitted and selected

## SM1000

Videographic recorder

### Standard Functionality

#### Operator Messages

**Number**

6

**Trigger**

Via front panel or digital signals

**Recording in alarm/event log**

Can be enabled or disabled on configuration

---

#### Process Alarms

**Number**

24 (2 per recording channel)

**Types**

High/low: process, latch & annunciator

Rate: fast/slow

**Tag**

20-character tag for each alarm

**Hysteresis**

Programmable value and time hysteresis (1 to 9999 s)

**Alarm enable**

Allows alarm to be enabled/disabled via a digital input

**Alarm log enable**

Recording of alarm state changes in the alarm/event log can be enabled/disabled for each alarm

**Acknowledgement**

Via front panel or digital signals

---

#### Real-time Alarms

**Number**

4

**Programmable**

Day of the week, 1<sup>st</sup> of month, start and duration times

---

#### Custom Linearization

**Number**

2

**Number of breakpoints**

20 per linearizer

#### Recording Duration

Approximate duration calculated for continuous recording of 6 channels of analog data (for 12 channels divide by 2, for 3 channels multiply by 2 etc.).

Sample Rate	1 s	10 s	40 s	60 s	120 s	480 s
1 Mb Internal Flash buffer memory	23 hours	9 days	38 days	57 days	4 months	1 year

### Recording to Internal Memory

#### Data Channels

**Internal buffer memory**

1 Mb Flash memory provides storage for 512 k samples

Oldest data is automatically overwritten by new data when memory is full

**Data integrity checks**

Checksum for each block of data samples

**Independent process groups**

2

**No. of recording channels**

12 (6 per group)

**Sources**

Analog inputs, Modbus™ inputs, any digital signal

**Filters**

Programmable for each channel to allow recording of: instantaneous values, average, max., min. and max. & min. value over sample time

**Primary/secondary sample rates**

Programmable from 0.1 s to 12 hours for each process group

**Primary/secondary sample rate selection**

Via any digital signal or from password protected menu

**Recording start/stop control**

Via any digital signal or from password protected menu

## SM1000

Videographic recorder

### Historical Logs

#### Types

Alarm/Event, Totalizer and Audit logs

#### No. of records in each historical log

Up to 200 in internal memory

Oldest data is automatically overwritten by new data when log is full

#### Historical Logs

Log Type	Alarm/Event Log		Totalizer Log		Audit Log	
<b>Log Entry Events</b>	<ul style="list-style-type: none"> <li>Alarm state changes</li> <li>Operator messages</li> </ul>		<ul style="list-style-type: none"> <li>User defined logging intervals</li> <li>Totalizer stop/start, reset, wrap</li> <li>Power up/down</li> </ul>		<ul style="list-style-type: none"> <li>Configuration/calibration changes</li> <li>System events</li> <li>Errors, operator actions</li> </ul>	
<b>Information Recorded in Log</b>	In Log	On Screen	In Log	On Screen	In Log	On Screen
Date & time of event	✓	✓	✓	✓	✓	✓
Type of event	✓	✓	✓	✓	✓	✓
Tag	✓	✓	✓	✓	—	—
Source tag	✓	—	✓	—	—	—
Alarm trip value & units of measure	✓	—	—	—	—	—
Alarm state	✓	✓	—	—	—	—
Alarm acknowledgement state	✓	✓	—	—	—	—
Operator ID	✓	—	—	—	✓	✓
Description	—	—	—	—	✓	✓
Batch total and units of measurement*	—	—	✓	✓	—	—
Max., Min. and average values plus units*	—	—	✓	✓	—	—
Secure total	—	—	✓	—	—	—

\* If Totalizer option fitted and selected

### Archiving to Removable Media

#### Data that can be saved to removable media

Recorded data for group 1 & 2 channels

Alarm event log data

Totalizer log data

Audit log data

Configuration

#### File Structure

Configurable as either binary encoded or comma-separated

#### Filename

20-character tag, prefixed with date/time

#### Data verification

Carried out automatically on all writes to removable-media files

#### Card compatibility

ABB recorders comply with approved industry standards for memory cards and ABB has fully tested and recommend the use of SanDisk Standard Grade or Ultra II memory cards. Other brands may not be fully compatible with this device and therefore may not function correctly.

#### Card size

Cards up to 4 Gb capacity may be used

### File Structure

	Binary	Comma-separated
File protection	Secure binary format with data integrity checks	Encrypted digital signature
New file generation interval	Automatic	Programmable for automatic file generation every hour, day or month
Archive sample rates	Programmable from 0.1 s to 12 hours for each process group*	Programmable from 1 s to 12 hours for each process group

\* For sample rates faster than 1 s the performance of the analog input card must be considered. For further information refer to page 14 of this data sheet. Further information is also available from you local ABB representative.

## SM1000

Videographic recorder

### Recording Duration

Approximate duration calculated for continuous recording of 6 channels of analog data (for 12 channels divide by 2, for 3 channels multiply by 2 etc.).

#### Binary Encoded File

Sample Rate	1 s	10 s	40 s	60 s	120 s	480 s
512 Mb Compact Flash	16 months	13 years	53 years	79 years	159 years	635 years
1 Gb Compact Flash	31 months	26 years	103 years	155 years	311 years	1246 years

#### Comma-separated File

Sample Rate	1 s	10 s	40 s	60 s	120 s	480 s
512 Mb Compact Flash	4 months	35 months	11 years	17 years	35 years	140 years
1 Gb Compact Flash	7 months	5 years	22 years	34 years	68 years	275 years

## Analog Input Modules

### General

#### Number of inputs

6 per board, max. of 12 inputs

#### Input types

mA, mV, voltage, resistance, THC, RTD

#### Thermocouple types

B, E, J, K, L, N, R, S, T

#### Resistance thermometer

PT100

#### Other linearizations

$\sqrt{x}$ ,  $x^{3/2}$ ,  $x^{5/2}$ , custom linearization

#### Digital filter

Programmable 0 to 60 s

#### Display range

−999 to 9999

#### Common mode noise rejection

> 120 dB at 50/60 Hz with 300  $\Omega$  imbalance resistance

#### Normal (series) mode noise rejection

> 60 dB at 50/60 Hz

#### CJC rejection ratio

0.05  $^{\circ}\text{C}/^{\circ}\text{C}$

#### Sensor break protection

Programmable as upscale or downscale

#### Temperature stability

0.02  $\%/^{\circ}\text{C}$  or 2  $\mu\text{V}/^{\circ}\text{C}$

#### Long term drift

< 0.2 % of reading or 20  $\mu\text{V}$  annually

#### Input impedance

> 10 M $\Omega$  (millivolts inputs)

500 k $\Omega$  (voltage inputs) externally mounted divider

10  $\Omega$  (mA inputs) externally mounted on terminals\*

\* Hart transmitters require a minimum 250  $\Omega$  loop impedance. A 250  $\Omega$  shunt resistor can be used together with the voltage divider board (GR2000/0375) to meet this requirement. In such cases the input should be programmed for 1...5 V.

## Standard/High Specification Analog Input Modules

Linear Inputs	Standard Analog Input	High Specification Analog Input	Accuracy (% of reading)
Millivolts	0 to 2000 mV	−1000 to +1000 mV	0.1 % or $\pm 10 \mu\text{V}$
Milliamps	0 to 50 mA	−100 to +100 mA	0.2 % or $\pm 2 \mu\text{A}$
Volts	0 to +20 V*	−50 to +50 V*	0.2 % or $\pm 10 \text{ mV}$
Resistance $\Omega$	0 to 5000 $\Omega$	0 to 2000 $\Omega$	0.2 % or $\pm 0.08 \Omega$
Sample Interval	100 ms per sample (2 modules are processed in parallel) gives worst case update times as follows: 600 ms for 6 or 12 channels — mV, mA, voltage 800 ms for 6 or 12 channels — THC 1100 ms for 6 or 12 channels — resistance, RTD	100 ms per sample (2 modules are processed in parallel) gives worst case update times as follows: 100 ms for 6 or 12 channels — all input types	
Input Isolation	35 V DC channel-to-channel	500 V DC channel-to-channel	
Isolation from Rest of Instrument	Galvanically isolated to 500 V DC	Galvanically isolated to 500 V DC	

\*Requires external voltage divider board Part No. GR2000/0375

## Analog Input Types

Thermocouple	Maximum Range $^{\circ}\text{C}$	Maximum Range $^{\circ}\text{F}$	Accuracy (% of reading)
B	−18 to 1800	0 to 3270	0.1 % or $\pm 2 \text{ }^{\circ}\text{C}$ (3.6 $^{\circ}\text{F}$ ) (above 200 $^{\circ}\text{C}$ [392 $^{\circ}\text{F}$ ])
E	−100 to 900	−140 to 1650	0.1 % or $\pm 0.5 \text{ }^{\circ}\text{C}$ (0.9 $^{\circ}\text{F}$ )
J	−100 to 900	−140 to 1650	0.1 % or $\pm 0.5 \text{ }^{\circ}\text{C}$ (0.9 $^{\circ}\text{F}$ )
K	−100 to 1300	−140 to 2350	0.1 % or $\pm 0.5 \text{ }^{\circ}\text{C}$ (0.9 $^{\circ}\text{F}$ )
L	−100 to 900	−140 to 1650	0.1 % or $\pm 1.5 \text{ }^{\circ}\text{C}$ (2.7 $^{\circ}\text{F}$ )
N	−200 to 1300	−325 to 2350	0.1 % or $\pm 0.5 \text{ }^{\circ}\text{C}$ (0.9 $^{\circ}\text{F}$ )
R	−18 to 1700	0 to 3000	0.1 % or $\pm 1 \text{ }^{\circ}\text{C}$ (1.8 $^{\circ}\text{F}$ ) (above 300 $^{\circ}\text{C}$ [540 $^{\circ}\text{F}$ ])
S	−18 to 1700	0 to 3000	0.1 % or $\pm 1 \text{ }^{\circ}\text{C}$ (1.8 $^{\circ}\text{F}$ ) (above 200 $^{\circ}\text{C}$ [392 $^{\circ}\text{F}$ ])
T	−250 to 300	−400 to 550	0.1 % or $\pm 0.5 \text{ }^{\circ}\text{C}$ (0.9 $^{\circ}\text{F}$ )

RTD	Maximum Range $^{\circ}\text{C}$	Maximum Range $^{\circ}\text{F}$	Accuracy (% of reading)
PT100	−200 to 600	−325 to 1100	0.1 % or $\pm 0.5 \text{ }^{\circ}\text{C}$ (0.9 $^{\circ}\text{F}$ )

## SM1000

Videographic recorder

### Advanced Math

#### Math Blocks

##### Type

12 equations provide ability to perform general arithmetic calculations including  $F_0$ , mass flow (of ideal gases), relative humidity and emissions calculations

##### Size

40-character equation

##### Functions

+, -, /, log, Ln, Exp,  $X_n$ ,  $\sqrt{\quad}$ , Sin, Cos, Tan, mean, rolling average, standard deviation, high/median/low select, multiplexer, absolute, relative humidity

##### Tags

8- and 20-character tags for each block

##### Update rate

1 enabled Math block is updated every 100 ms

---

### Logic Equations

#### Number

12

#### Size

11 elements each

#### Functions

AND, OR, NAND, NOR, XOR, NOT

#### Tags

20-character tag for each equation

#### Update rate

300 ms

---

### Modules

#### 3- or 6-Relay Output Modules

##### Number of relays

3 or 6 per module

##### Type and rating

Relay type single-pole changeover

Voltage	250 V AC	30V DC
Current	5 A AC	5 A DC
Loading (non-inductive)	1250VA	150 $\Omega$

**Note.** The total load for all relays within the instrument must not exceed 36 A.

### Hybrid Module

#### Digital I/O

Number	6 inputs and 6 outputs per card
Type	Volt-free switching inputs
Polarity	Negative, i.e. closed switch contact or 0 V = active signal
Digital input min. pulse	100 ms
Digital output voltage	5 V
Isolation	500 V DC from any other I/O

#### Analog output

Number	2 isolated
Configurable current range	0 to 20 mA
Max. load	750 $\Omega$
Isolation	500 V DC from any other I/O
Accuracy	0.25 %

---

### 2-Wire Transmitter Power Supply Module

#### Number

2 isolated supplies per module

#### Voltage

24 V DC nominal

#### Drive

45 mA per supply, i.e. each module can drive  $2 \times 2 = 4$  loops

---

### Ethernet Module

#### Physical medium

10BaseT

#### Protocols

TCP/IP, ARP, ICMP, FTP (server), HTTP, MODBUS TCP (client, server)

#### FTP server functions

Directory selection & listing

File upload/download

Four, independently configurable users with full or read-only access

#### Web server functions

Operator screen monitoring/selection. Remote monitoring of recording channels, analog/digital signals, alarms, totalizers and archiving



## SM1000

Videographic recorder

### RS485 Serial Communications Module

#### Number of ports

1 as option

#### Connections

RS485, 2- or 4-wire

#### Protocol

Modbus™ RTU slave + master

---

### Totalizer (optional)

#### Number

12 (1 per recording channel) 10-digit totals

#### Type

Analog or digital, batch and secure totals

#### Statistical calculations

Average, maximum, minimum (for analog signals)

---

### EMC

#### Emissions & Immunity

Meets requirements of:

EN50081-2

EN50082-2

EN61326 for an industrial environment

---

### Electrical

#### Power supply

100 to 240 V AC  $\pm 10\%$  (90 min. to 264 V max.) 50/60 Hz

24 V DC  $\pm 4$  V (optional)

#### Power consumption

35 VA max.

#### Power interruption protection

No effect for interruptions of up to 20 ms

---

### Safety

#### General safety

EN61010-1

cULus

cCSAus

Overvoltage Class III on mains, Class II on inputs and outputs

Pollution category 2

#### Isolation

500 V DC to earth (ground)

### Environmental

#### Operating temperature range

0 to 50 °C (32 to 122 °F) with Compact Flash

#### Operating humidity range

5 to 95 % RH (non-condensing)

#### Storage temperature range

–10 to 60 °C (14 to 140 °F)

#### Front panel sealing

IP66 and NEMA4X

#### Rear panel sealing

IP40 (with rear cover)

IP20 (without rear cover)

#### Vibration

Conforms to EM60068-2

---

### Physical

#### Size

144 mm (5.67 in.) x 144 mm (5.7 in.) x

195 mm (7.68 in.) depth behind panel

#### Weight

2.6 kg (5.6 lb) approx. (unpacked)

#### Panel cutout

138 mm (5.43 in.) x 138 mm (5.43 in.)

#### Case material

10 % glass-filled polycarbonate

#### Display housing material

40 % glass-filled polycarbonate

#### Membrane switch

Polyester, metal dome, tactile feel

## Electrical Connections

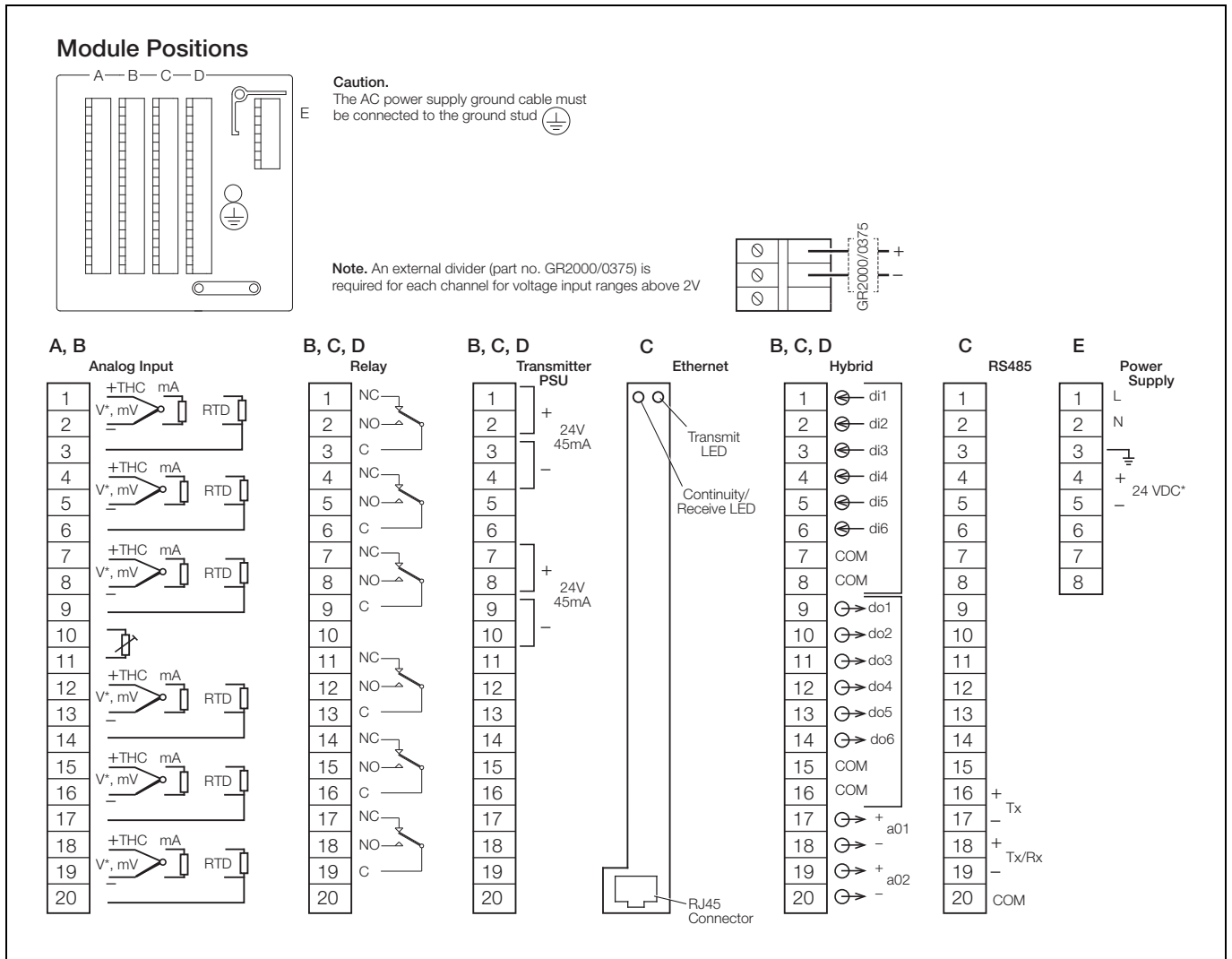

\*Note. 24 V DC instrument power supply must be specified when ordering.

## Overall Dimensions

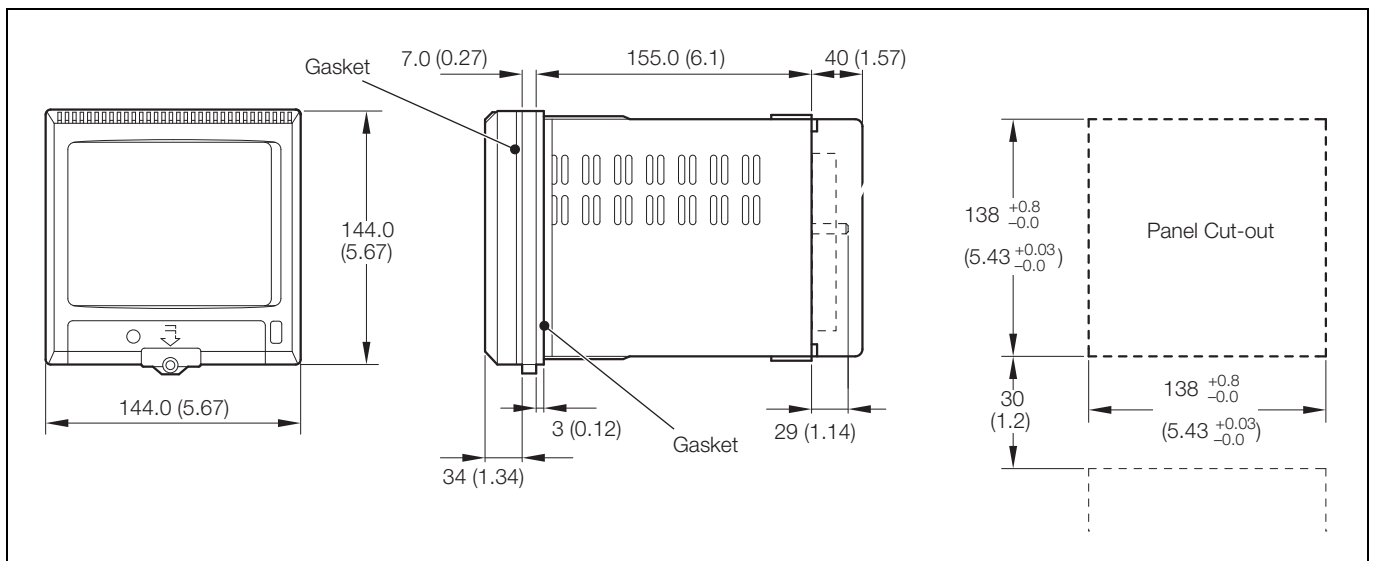

**SM1000**

Videographic recorder

**Ordering Information**

SM1000 Videographic Recorder	SM10	XXX/	X	X	X/	X	X	X	X/	X	X/	XXX
<b>Universal Analog Inputs</b>												
None		00S										
6 – standard specification		06S										
12 – standard specification		12S										
6 – high specification		06H										
12 – high specification		12H										
<b>Build Option</b>												
Standard			B									
cCSAus*			C									
UL*			U									
<b>Archive Media</b>												
None (internal flash memory only)					0							
Compact Flash drive					2							
<b>Software Option</b>												
None						0						
Advanced Math & Logic						1						
Totalizers						2						
Advanced Math & Logic & Totalizers						3						
Batch Recording						4						
Batch Recording & Totalizers						5						
Batch Recording & Advanced Math & Logic						6						
Advanced Math & Logic, Totalizers & Batch Recording						7						
<b>Option Modules</b>												
<b>Position A</b>	Reserved for analog inputs									0		
	Reserved for analog inputs if 12 inputs are specified										0	
	3 relays										3	
<b>Position B</b>	6 relays										6	
	Hybrid – 6 digital inputs, 6 digital outputs, 2 analog outputs										H	
	2-wire transmitter power supply										T	
	None											0
	3 relays											3
	6 relays											6
<b>Position C</b>	Ethernet (10BaseT) communications											E
	RS485 Modbus serial communications											S
	Hybrid – 6 digital inputs, 6 digital outputs, 2 analog outputs											H
	2-wire transmitter power supply											T
	None											
	3 relays											3
	6 relays											6
<b>Position D</b>	Hybrid – 6 digital inputs, 6 digital outputs, 2 analog outputs											H
	2-wire transmitter power supply											T
<b>Case</b>												
Without terminal compartment												2
With terminal compartment												3
<b>Power Supply</b>												
100 to 240 V AC ±10 % (90 min. to 264 V max.) 50/60 Hz												2
24 V DC												3
<b>Special Features</b>												
Standard												STD
Custom configuration												CUS
GAMP validation compatible instrument**												VAL

\* Not available in conjunction with 24 V DC power supply

\*\* Instrument supplied preconfigured to customer's requirements, together with calibration and conformity certificates. Configuration must be supplied using custom configuration sheet – INF08/034

## SM1000

Videographic recorder

### Standard Accessories

Included with each recorder:

Panel-mounting Clamps

Media-door Lock keys

Shunt Resistors (1 per analog input)

Compact Flash Card (only with Compact Flash Memory Card option)

### Optional Accessories

#### Compact Flash Cards

B12158 Compact Flash Card (2 Gb)

#### Card Reader

B12028 Compact Flash Reader (USB Interface)

#### Other

GR2000/0375 Voltage divider board (2 to 20 V) – per voltage input channel

GR2000/0375 Voltage divider board fitted with a 250  $\Omega$  shunt resistor

RDM500-CD DataManager Pro software

RDM500L DataManager Pro single user license

RDM500ML DataManager Pro multi-user license

CD/VALSM1000 SM1000 validation package template

# Contact us

## **ABB Limited**

### **Process Automation**

Howard Road

St. Neots

Cambridgeshire PE19 8EU

UK

Tel: +44 (0)1480 475321

Fax: +44 (0)1480 217948

## **ABB Inc.**

### **Process Automation**

125 E. County Line Road

Warminster

PA 18974

USA

Tel: +1 215 674 6000

Fax: +1 215 674 7183

**[www.abb.com](http://www.abb.com)**

## Note

We reserve the right to make technical changes or modify the contents of this document without prior notice. With regard to purchase orders, the agreed particulars shall prevail. ABB does not accept any responsibility whatsoever for potential errors or possible lack of information in this document.

We reserve all rights in this document and in the subject matter and illustrations contained therein. Any reproduction, disclosure to third parties or utilization of its contents in whole or in parts – is forbidden without prior written consent of ABB.

Copyright© 2012 ABB

All rights reserved

3KXR101001R1001

Microsoft is a registered trademark of Microsoft Corporation in the United States and/or other countries

Modbus is a registered trademark of the Modbus-IDA organization